

**Appendix M:
Revised 2018 Focused Traffic Impact Assessment**

THIS PAGE INTENTIONALLY LEFT BLANK

August 15, 2018

Mr. Stephen D. Foulkes
P.O. Box 7105
Newport Beach, CA 92660

SUBJECT: MOON CAMP FOCUSED TRAFFIC IMPACT ASSESSMENT

Dear Mr. Stephen D. Foulkes:

Urban Crossroads, Inc. is pleased to provide the following Focused Traffic Impact Assessment for the proposed Moon Camp (“Project”), which is located at North Shore Drive, in the County of San Bernardino. The Project is to consist of up to 50 new single-family residential dwelling units.

BACKGROUND

The potential traffic impacts associated with development of the Project were previously analyzed in *Moon Camp Traffic Impact Analysis* (Urban Crossroads, June 29, 2007) (referred to as “2007 TIA”). Comparison of traffic count data at each of the study area intersections between 2007 and 2016 indicate that the overall intersection volumes have generally decreased for each intersection with one exception. The Sunday (mid-day) peak hour volume for the intersection of Stanfield Cutoff and North Shore Drive indicated an increase of 12%. Existing Sunday (Mid-Day) volumes in PCE are shown on Exhibit 1. The traffic count data and summary of comparison information is included in Attachment A.

The purpose of this focused analysis is to evaluate whether the increased traffic volumes at the intersection of Stanfield Cutoff and North Shore Drive for Sunday (mid-day) peak hour would alter any of the previous findings as reported in the 2007 TIA. In addition, the fair share costs presented in the 2007 TIA have been updated and sight distance evaluation at the proposed Project driveways on North Shore Drive has been included.

SUMMARY OF FINDINGS

The improvements for the Stanfield Cutoff and North Shore Drive intersection previously identified in the 2007 TIA for Near-term traffic conditions included a new traffic signal and left-turn lanes on all legs. The improvements identified for Long-Range traffic conditions included additional northbound left-turn and eastbound right-turn lanes. Based on this evaluation the traffic forecasts for both Near-term and Long-Range conditions can be accommodated by the improvements previously identified in the 2007 TIA. In other words, no additional improvements beyond those previously identified in the 2007 TIA are required to achieve an acceptable level of service.

The Project’s fair share costs presented in the 2007 TIA have been updated based on current unit costs utilized by San Bernardino County and traffic volumes based on Existing (2016) traffic counts and

updated Horizon year (2040) forecasts as requested by San Bernardino County staff. The updated fair share cost is approximately \$99,320.

Traffic signal warrant analysis for the Project driveways at North Shore drive were conducted based on General Plan Buildout (2030) volumes. The evaluation indicated that the intersection of Project driveways and North Shore Drive do not meet the ADT volume based warrant based on California Manual on Uniform Traffic Control Devices (CA MUTCD).

A sight distance analysis has been performed for the Project access points on North Shore Drive to determine acceptable stopping sight distances consistent with the requirements outlined in the Caltrans Highway Design Manual (6th Edition, 2016) to provide full access at Project’s western driveway (Driveway 1), eastern driveway (Driveway 2) and Marina exit.

PROJECT TRIP GENERATION

The Project consist of up to 50 new single-family residential dwelling units and there has been no changes in the number of units from what was analyzed in the 2007 TIA. Traffic generation rates for the proposed Project have been derived from Institute of Transportation Engineers (ITE) Trip Generation (9th Edition, 2012). As shown on Table 1, the Project is anticipated to generate a net total of 476 trip-ends per day on a typical weekday with approximately 38 AM peak hour trips and 50 PM peak hour trips. It is our understanding that weekday PM peak hour generates more trips than the Sunday (mid-day) peak hour. However, consistent with the 2007 TIA, weekday PM peak hour trip generation has been used in the Sunday (mid-day) peak hour analysis to represent a conservative worst case condition.

TABLE 1: PROJECT TRIP GENERATION SUMMARY

Land Use	ITE LU Code	Units ²	Weekday AM Peak Hour			Weekday PM Peak Hour			Weekday Daily
			In	Out	Total	In	Out	Total	
Project Trip Generation Rates¹									
Single Family Detached Residential	210	DU	0.19	0.56	0.75	0.63	0.37	1.00	9.52

Project	Quantity	Units ²	Weekday AM Peak Hour			Weekday PM Peak Hour			Weekday Daily
			In	Out	Total	In	Out	Total	
Project Trip Generation Summary									
Single Family Detached Residential	50	DU	10	28	38	32	19	50	476

¹ Trip Generation Source: Institute of Transportation Engineers (ITE), Trip Generation, Ninth Edition (2012).

² DU = Dwelling Units

PROJECT TRIP DISTRIBUTION

Trip distribution is the process of identifying the probable destinations, directions or traffic routes that will be utilized by Project traffic. The potential interaction between the planned land uses and surrounding regional access routes are considered, to identify the route where the Project traffic would distribute.

The Project trip distribution and assignment process represents the directional orientation of traffic to and from the Project site. The trip distribution pattern of passenger cars is heavily influenced by the geographical location of the site, the location of surrounding land uses, and the proximity to the regional freeway system. The Project passenger car trip distribution patterns is graphically depicted on Exhibit 2.

TRAFFIC FORECASTS

NEAR-TERM (2021) TRAFFIC VOLUMES

The Near-term (2021) Without Project traffic volumes have been estimated based on Existing (2016) traffic volumes (with 16% adjustment to account for peak season) plus an ambient growth rate from Existing (2016) conditions of 10.41% (2 percent per year, over 5 years) plus traffic generated by known cumulative developments shown on Table 2 and Exhibit 3. The Near-term (2021) Sunday (mid-day) Without Project peak hour turning movement volumes is shown on Exhibit 4.

The Near-term (2021) With Project traffic volumes were calculated by manual addition of Project traffic to Near-term (2021) Without Project volumes. The Near-term (2021) Sunday (mid-day) With Project peak hour turning movement volumes is shown on Exhibit 5.

TABLE 2: CUMULATIVE PROJECT LIST

#	Project Type	Name/Area	Description	Number of Units/Size
1	Marina Point	Okovita	SFDR	120 DU
2	TT 17670	Sobczyk/Fawn	SFDR	22 DU
3	TT 17217 & TT17022	Stinson, Lisa A Moonridge	SFDR	53 DU
4	TPM 19262	Musto/Baldwin	SFDR	4 DU
5	TT 18806	Burtner/Erwin	SFDR	18 DU
6	Conv Store/Gas Station/Residence	Munem Maida	Conv Store/Gas Station/Residence	12 VFP / 1 DU
7	CUP 2000-52	The Club	Timeshare	61 DU

8	TT 16611	Shadow Mtn	SFDR	8 DU
9	TT 18580	Morgan Pines	SFDR	23 DU
10	CUP 2008-319	Bay Meadows	Conf Center	11.500 TSF
11	Relocation	Moonridge Zoo	Animal Park	- -
12	618 Pineknot	N.P. Fudge	Apartments	2 DU

SFDR = Single Family Detached Residential; DU= Dwelling Units; TSF = Thousand Square Feet; VFP = Vehicle Fueling Positions

HORIZON YEAR (2040) TRAFFIC VOLUMES

The Horizon Year (2040) Without Project traffic volumes have been estimated based on current version of the San Bernardino County Traffic Analysis Model (SBTAM) using accepted procedures for model forecast refinement and smoothing. The Horizon Year (2040) Sunday (mid-day) Without Project peak hour turning movement volumes is shown on Exhibit 6.

The Horizon Year (2040) With Project traffic volumes were calculated by manual addition of Project traffic to Horizon Year (2040) Without Project volumes. The Horizon Year (2040) Sunday (mid-day) With Project peak hour turning movement volumes is shown on Exhibit 7.

INTERSECTION OPERATIONS ANALYSIS

Peak Hour intersection operations analysis was conducted at the intersection of Stanfield Cutoff and Northshore Drive based on Highway Capacity Manual (HCM) 2010 methodology consistent with County of San Bernardino requirements using Synchro (Version 9) software.

The intersection was evaluated with recommended improvements consistent with the 2007 TIA. The intersection operations analysis results with recommended improvements for Near-term (2021) and Horizon Year (2040) traffic conditions are shown on Table 3. The recommended improvements for near-term conditions in the 2007 TIA are identified below:

- Install a traffic signal
- Add northbound left turn lane
- Add southbound left turn lane
- Add eastbound left turn lane
- Add westbound left turn lane

As shown on Table 3, the intersection of Stanfield Cutoff and Norths Shore Drive is anticipated to operate at acceptable LOS C for both Near-term (2021) without and with Project traffic conditions with improvements consistent with near-term improvements recommended in 2007 TIA.

The additional recommended improvements for General Plan Buildout conditions in the 2007 TIA is identified below:

- Add 2nd northbound left turn lane
- Add eastbound right turn lane with overlap phasing

As shown on Table 3, the intersection of Stanfield Cutoff and Norths Shore Drive is anticipated to operate at acceptable LOS B for both Horizon Year (2040) without and with Project traffic conditions with improvements consistent with General Plan Buildout improvements recommended in 2007 TIA.

The intersection operations analysis worksheets, with improvements, are included in Attachment B.

Based on this evaluation the traffic forecasts for both Near-term and Long-range conditions can be accommodated by the improvements previously identified in the 2007 TIA. In other words, no additional improvements beyond those previously identified in the 2007 TIA are required to achieve an acceptable level of service.

FAIR SHARE COST UPDATE

The long-range improvement costs and Project's fair share identified in Tables 6-1 and 6-2 in the 2007 TIA have been updated based on current unit costs utilized by San Bernardino County and traffic volumes based in Existing (2016) traffic counts and updated Horizon year (2040) forecasts as requested by San Bernardino County staff. Table 4 indicates the long-range improvements and resulting costs. Table 5 includes the Project's contribution based on the Project's percent of new traffic. As indicated in Table 5, the highest Friday PM or Sunday Mid-day fair share cost is approximately \$99,320.

TRAFFIC SIGNAL WARRANT ANALYSIS

The term "signal warrants" refers to the list of established criteria used by Caltrans and other public agencies to quantitatively justify or ascertain the potential need for installation of a traffic signal at an otherwise unsignalized intersection. This assessment uses the signal warrant criteria presented in the latest edition of the Federal Highway Administration's (FHWA) *Manual on Uniform Traffic Control Devices (MUTCD)*, as amended by *the MUTCD 2014 California Supplement*. Specifically, the intersections have been assessed based on future ADT volumes, using the Caltrans planning level ADT-based signal warrant analysis worksheets.

The intersections of Driveway 1/North Shore Drive and Driveway 2/North Shore Drive are not anticipated to warrant a traffic signal based on General Plan Buildout (2030) ADT presented in the 2007 TIA. Traffic signal warrant analysis worksheets are included in Attachment C.

It is important to note that a signal warrant defines the minimum condition under which the installation of a traffic signal might be warranted. Meeting this threshold condition does not require that a traffic control signal be installed at a particular location, but rather, that other traffic factors and conditions be

evaluated in order to determine whether the signal is truly justified.

SIGHT DISTANCE AND SIGHT ACCESS EVALUATION

As defined by the Caltrans HDM, sight distance is the continuous length of highway ahead visible to the driver. Stopping sight distance is the minimum sight distances provided at interchanges and at-grade intersections.

At unsignalized intersections, intersection sight distance must provide a substantially clear line of sight between the driver of the vehicle waiting on the minor road (driveway) and the driver of an approaching vehicle. For the purposes of this analysis, a 7 ½ second criterion has been applied to the outside travel lanes in either direction to provide the most conservative sight distance. The 7 ½ second criterion allows waiting vehicles to either cross all lanes of through traffic by turning left or cross the near lanes by tuning right without requiring through traffic to radically alter their speed.

The Project proposes three driveways on North Shore Drive (SR-38) for access to the residential homes and the Marina. Driveway 1 is proposed to provide ingress and egress to the residential homes via a gated entrance. Driveway 2 is proposed to provide ingress and egress to the residential homes via a gated entrance, as well as entrance to the Marina to the south. An additional driveway is proposed from the Marina for egress only. All the driveways are proposed to have full access. Left turn pockets are proposed to be constructed at both Driveway 1 and Driveway 2. In addition, a Class II Bicycle Lane is also proposed to be constructed on SR-38 in the eastbound direction. As indicated in Highway Design Manual Section 405.3, for right-turning traffic, delays are less critical and conflicts less severe than for left-turning traffic. Right turn pockets are not proposed on SR-38 at Driveway 1 and Driveway 2 because of the nominal right turning volume (less than 20 peak hour trips) at both the driveways.

As the Project driveways intersect with a California State Highway (SR-38), the sight distance evaluation has been performed based on the Caltrans methodology defined in the Caltrans Highway Design Manual (HDM). Exhibits 8, 9, and 10 illustrate the sight distance requirements for the Project driveways on North Shore Drive (SR-38) consistent with the Caltrans methodology. Based on the current posted speed limit on North Shore Drive (SR-38) of 25 miles per hour, the minimum sight distance to be provided is 275-feet. As shown on Exhibits 8, 9, and 10, the length of the sight distance line was determined to be approximately 275-feet to the west and east of the driveways which meets the Caltrans recommended sight distance. The cross-hatched region on the corners of the intersection indicates the limited use area. The limited use area should remain clear of objects taller than 30 inches.

Sight distance at each of the Project access point should be reviewed with respect to standard Caltrans and County of San Bernardino sight distance standards at the time of preparation of final grading, landscape and street improvement plans. With the provision of adequate sight distance, full access can be provided at the Project driveways and the Marina exit.

Mr. Stephen D. Foulkes
Stephen D. Foulkes
August 15, 2018
Page 7 of 7

If you have any questions, please contact me directly at (949) 336-5992.

Respectfully submitted,

URBAN CROSSROADS, INC.

A handwritten signature in black ink, appearing to read 'Praneesh Tarikere', with a stylized flourish at the end.

Praneesh Tarikere, PE
Senior Engineer

EXHIBIT 1: EXISTING (2016) SUNDAY (MID-DAY) PEAK VOLUMES (IN PCE)

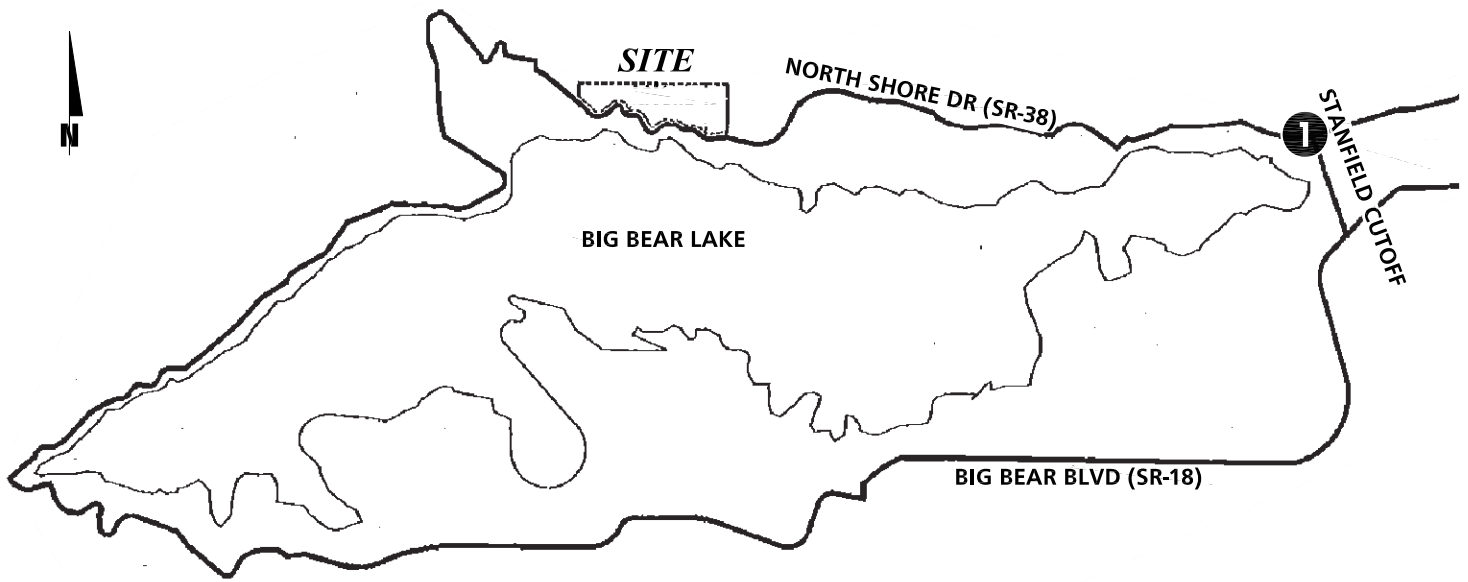

1 Standfield Cutoff & North Shore Dr.	
<p>Diagram showing traffic flow and volumes at the Standfield Cutoff and North Shore Dr intersection. The diagram includes arrows indicating traffic direction and numerical values for peak volumes.</p>	<p>7 115 240</p> <hr/> <p>180 9 182</p>
<p>3 2 14</p>	<p>0 110 173</p>

EXHIBIT 2: PROJECT TRIP DISTRIBUTION

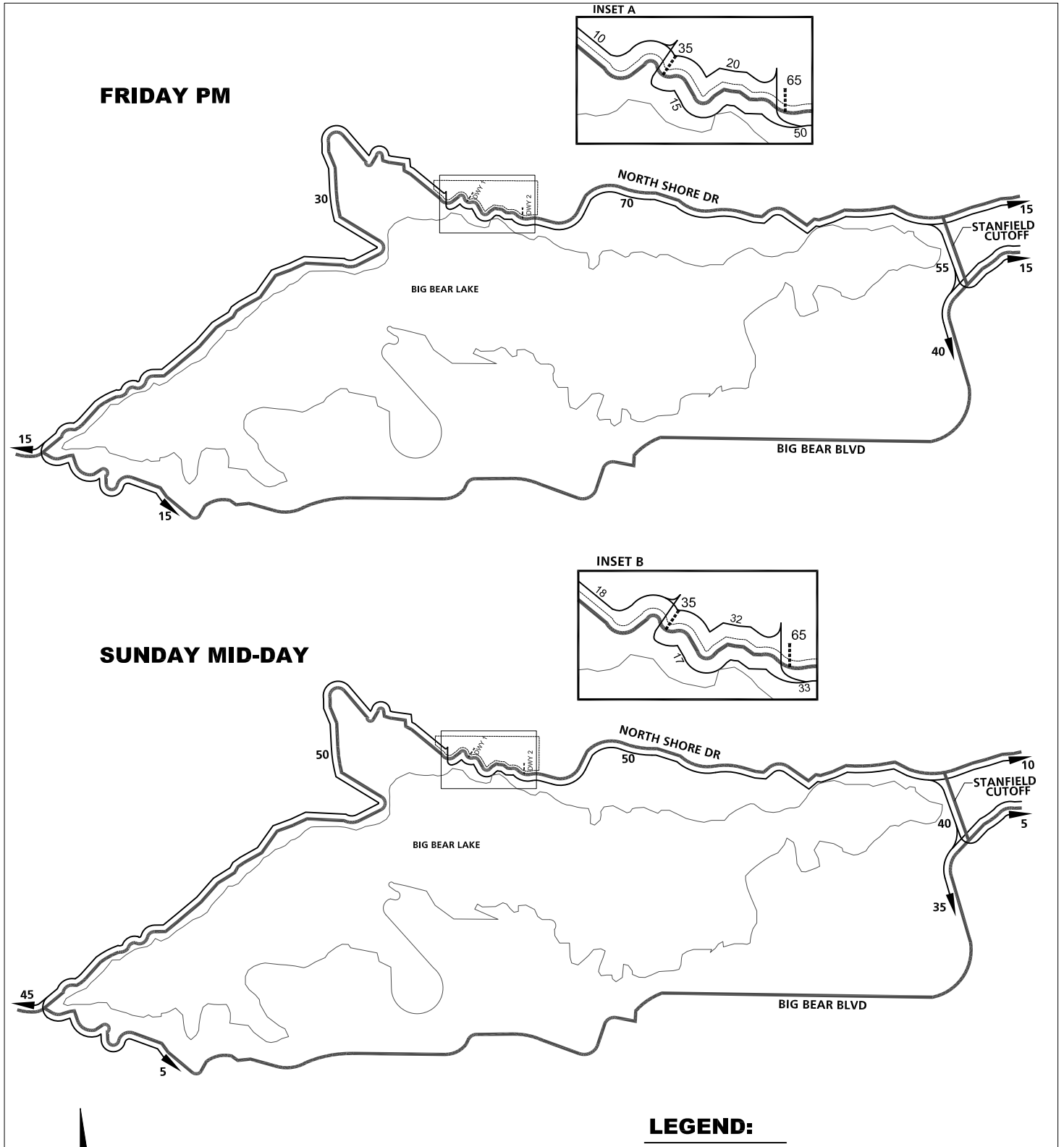
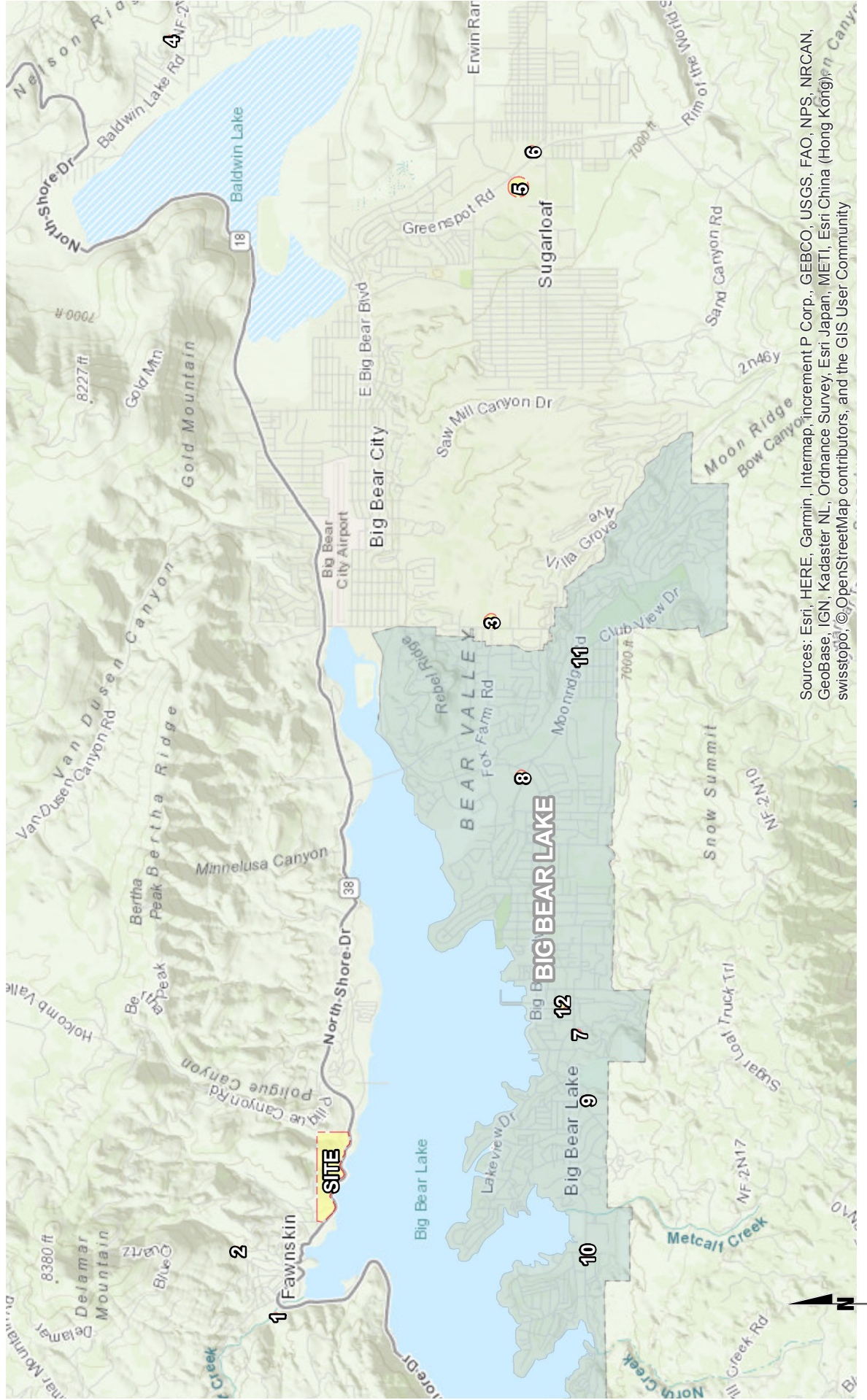
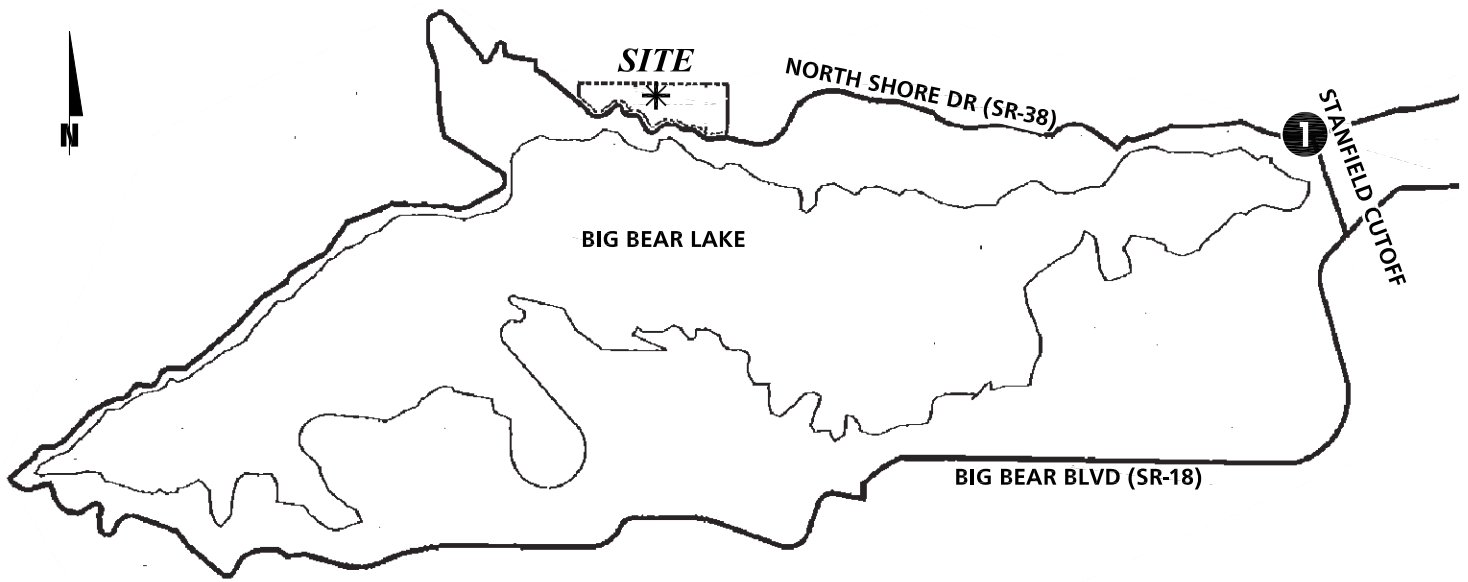

EXHIBIT 3: CUMULATIVE DEVELOPMENT LOCATION MAP



Sources: Esri, HERE, Garmin, Intermap, increment P Corp., GEBCO, USGS, FAO, NPS, NRCAN, GeoBase, IGN, Kadaster NL, Ordnance Survey, Esri Japan, METI, Esri China (Hong Kong), Swisstopo, ©OpenStreetMap contributors, and the GIS User Community

EXHIBIT 4: NEAR-TERM (2021) WITHOUT PROJECT SUNDAY (MID-DAY) PEAK VOLUMES (IN PCE)



1 Standfield Cutoff & North Shore Dr.	

EXHIBIT 5: NEAR-TERM (2021) WITH PROJECT SUNDAY (MID-DAY) PEAK VOLUMES

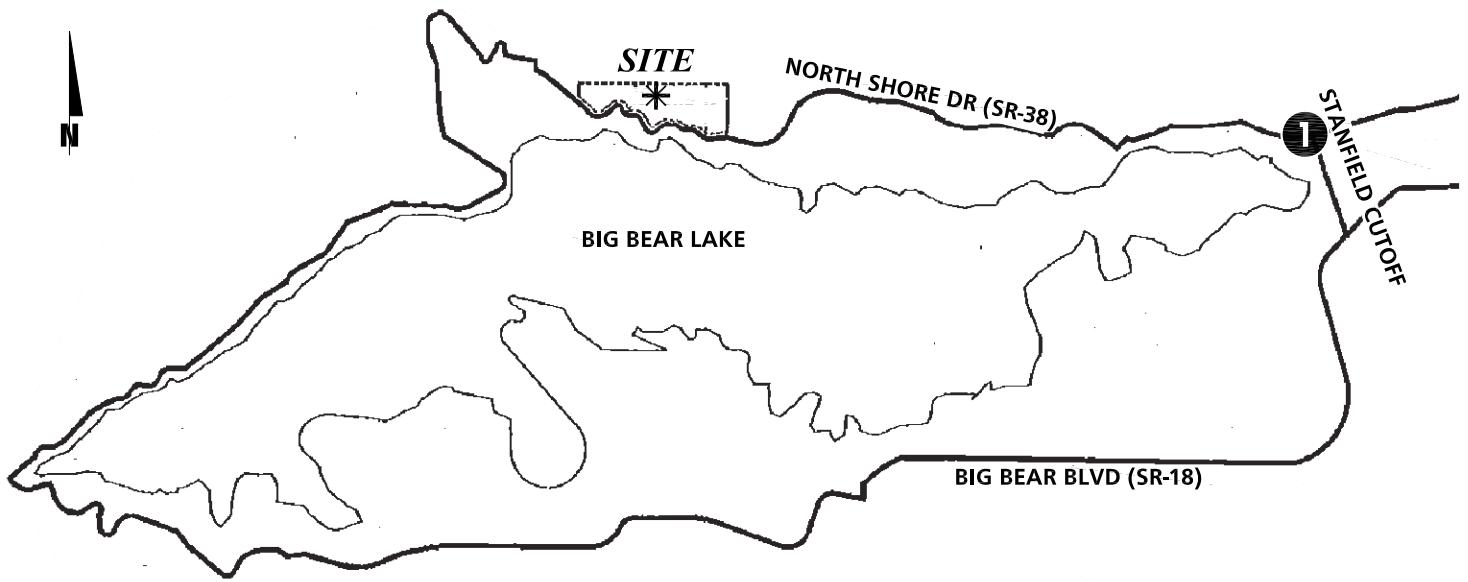

1 Standfield Cutoff & North Shore Dr.	

EXHIBIT 6: HORIZON YEAR (2040) WITHOUT PROJECT SUNDAY (MID-DAY) PEAK VOLUMES

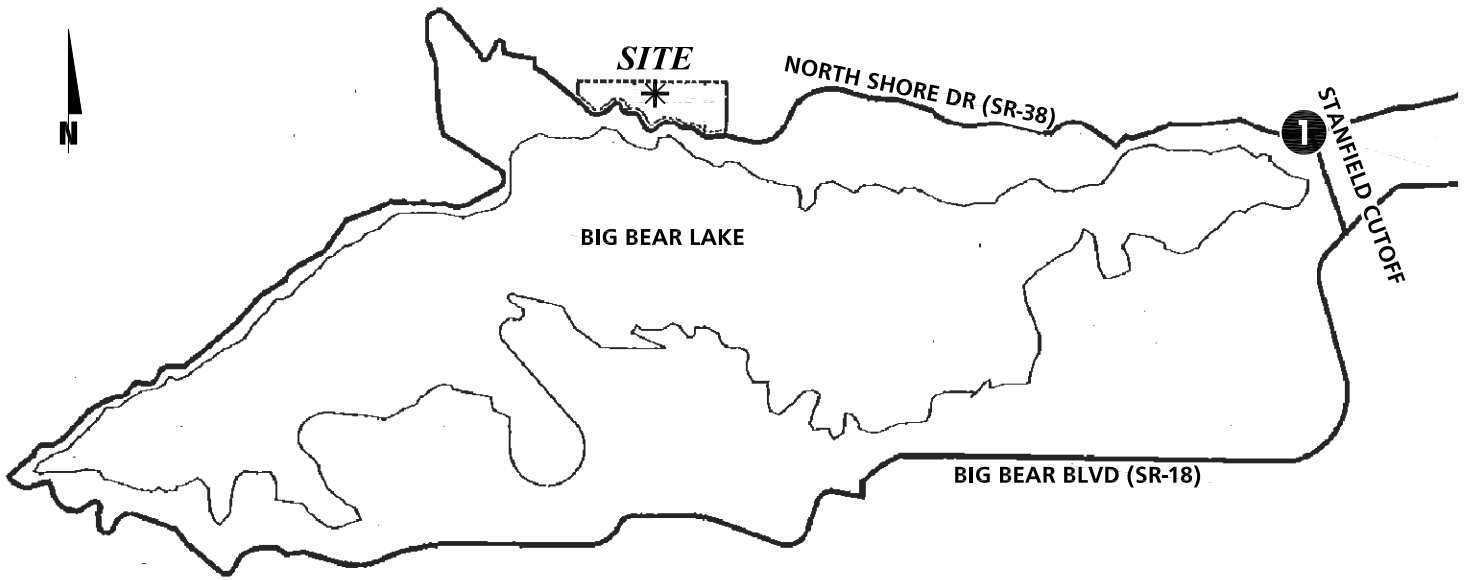

1 Standfield Cutoff & North Shore Dr.

4	2	17	9	150	292
0	139	237	263	11	221

EXHIBIT 7: HORIZON YEAR (2040) WITH PROJECT SUNDAY (MID-DAY) PEAK VOLUMES

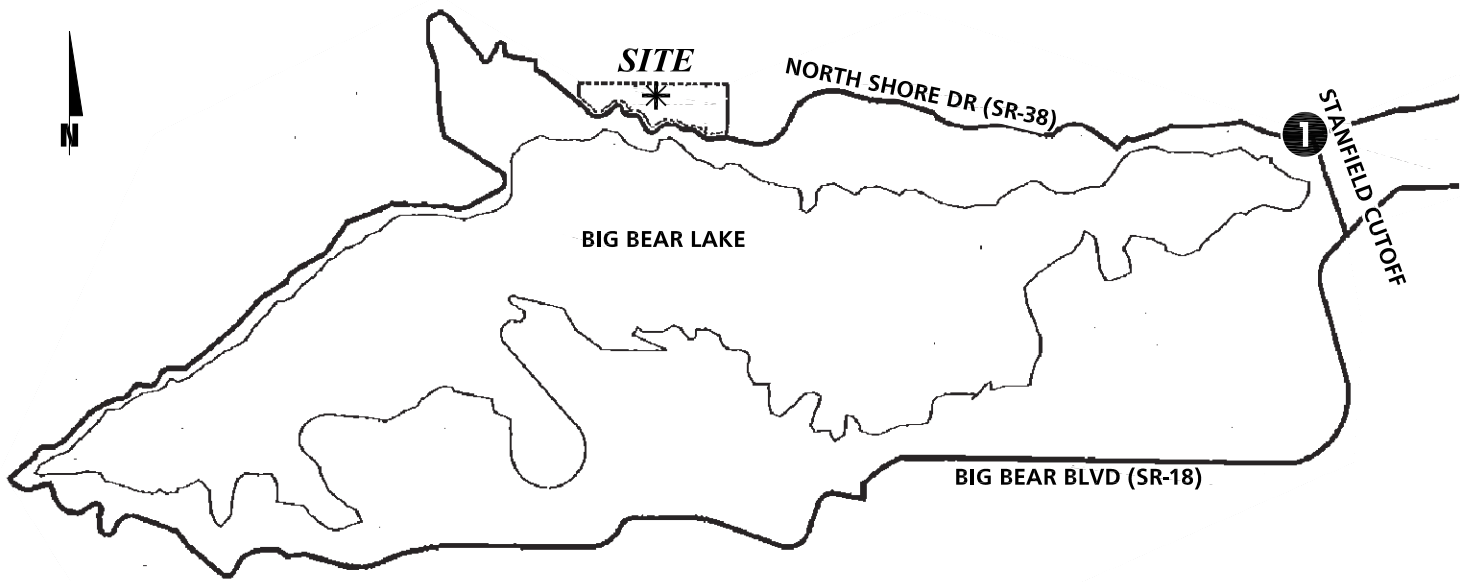

1 Standfield Cutoff & North Shore Dr.

4	17	9
2	153	292
0	276	11
141	221	
245		

EXHIBIT 10: SIGHT DISTANCE (LEFT TURNS)

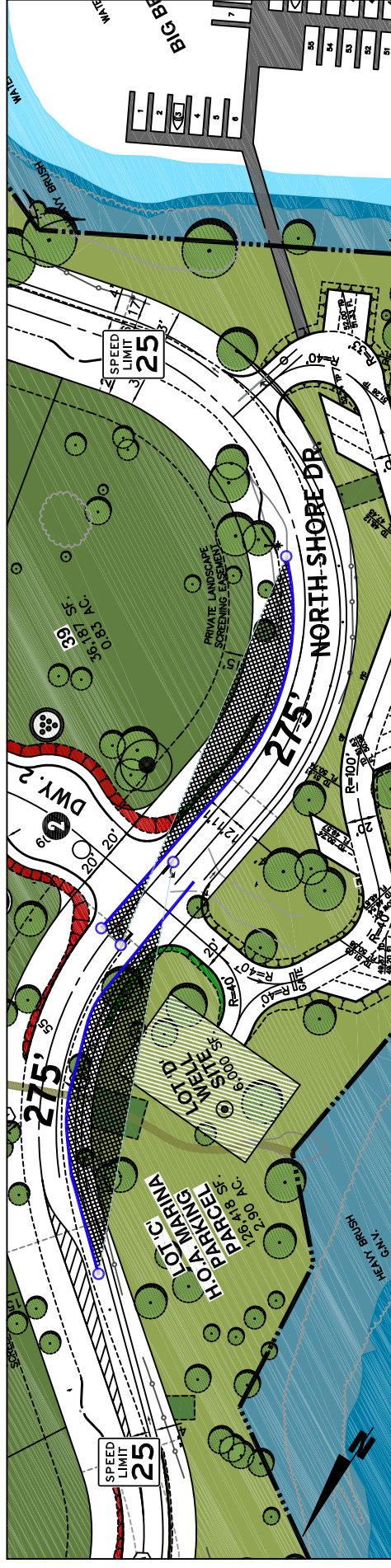
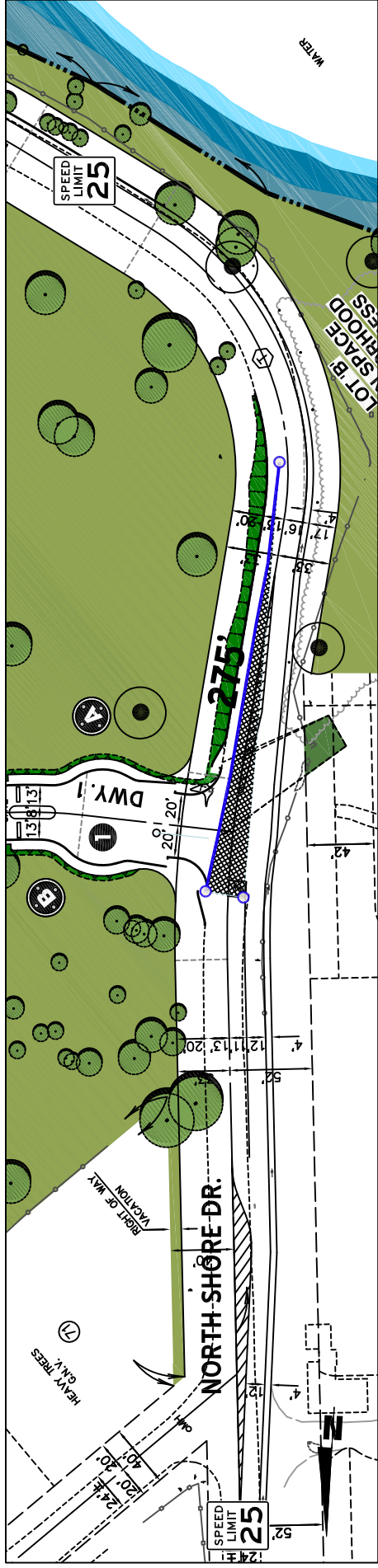

LEGEND:

- = MINIMUM SIGHT DISTANCE LINES
- = LIMITED USE AREA

(THERE SHALL BE NO OBSTRUCTION WITHIN THE LIMITED USE AREA. OBSTRUCTIONS INCLUDE, BUT NOT LIMITED TO, ANY SIGNS OR OBJECTS HIGHER THAN 2.5' MEASURED FROM PAVEMENT WITHIN THE AREA OF LIMITED USE.)

1	Dwy. 1 & 2 North Shore Dr.		
2	Dwy. 2 & 3 North Shore Dr.		

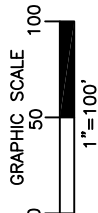
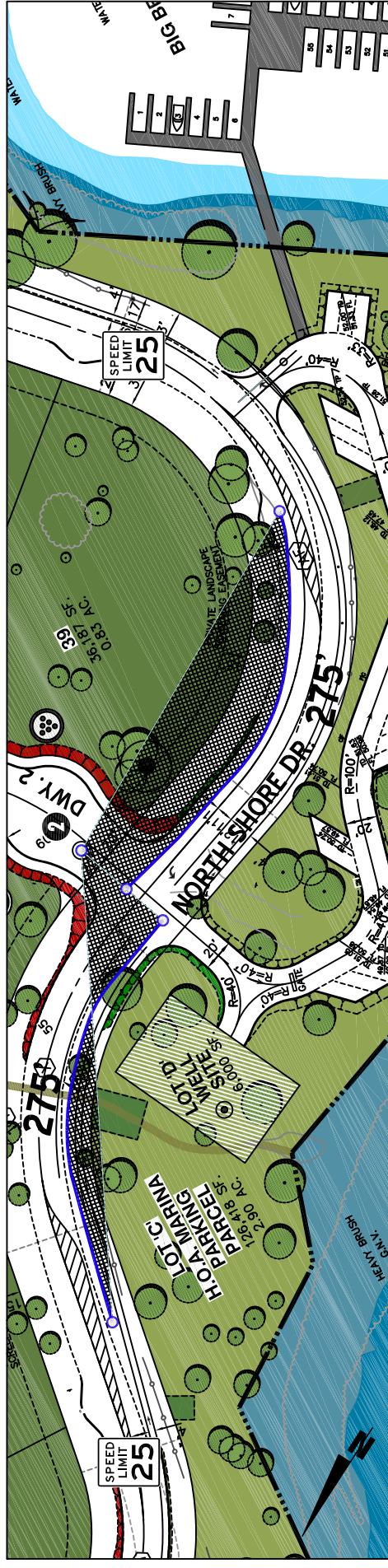
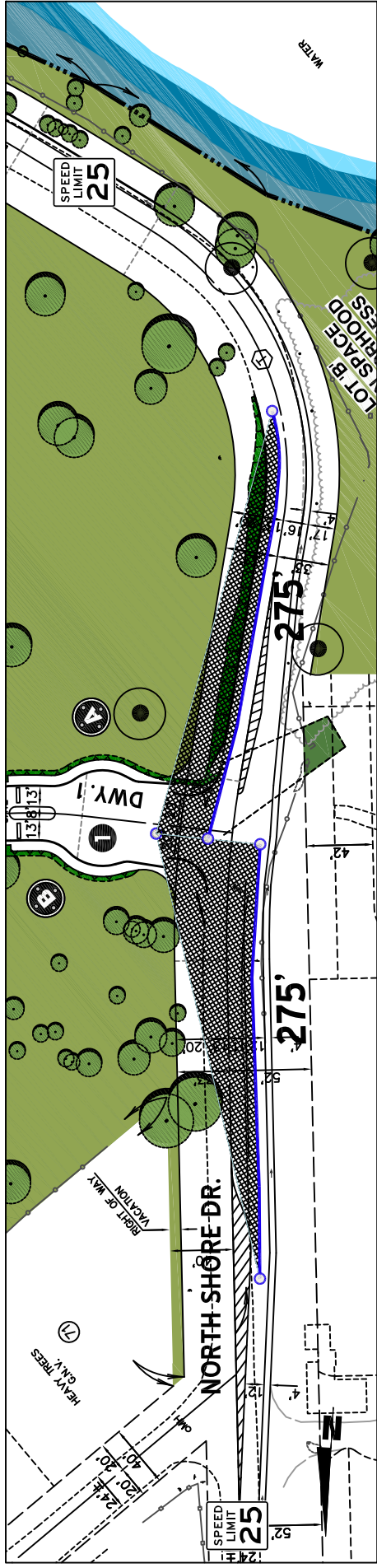

EXHIBIT 8: SIGHT DISTANCE (PROJECT DRIVEWAYS)



LEGEND:

— = MINIMUM SIGHT DISTANCE LINES

▨ = LIMITED USE AREA

(THERE SHALL BE NO OBSTRUCTION WITHIN THE LIMITED USE AREA. OBSTRUCTIONS INCLUDE, BUT NOT LIMITED TO, ANY SIGNS OR OBJECTS HIGHER THAN 2.5' MEASURED FROM PAVEMENT WITHIN THE AREA OF LIMITED USE.)



	Dwy. 1 & 2 North Shore Dr.	Dwy. 2 & North Shore Dr.
1		

EXHIBIT 9: SIGHT DISTANCE (MARINA DRIVEWAY)

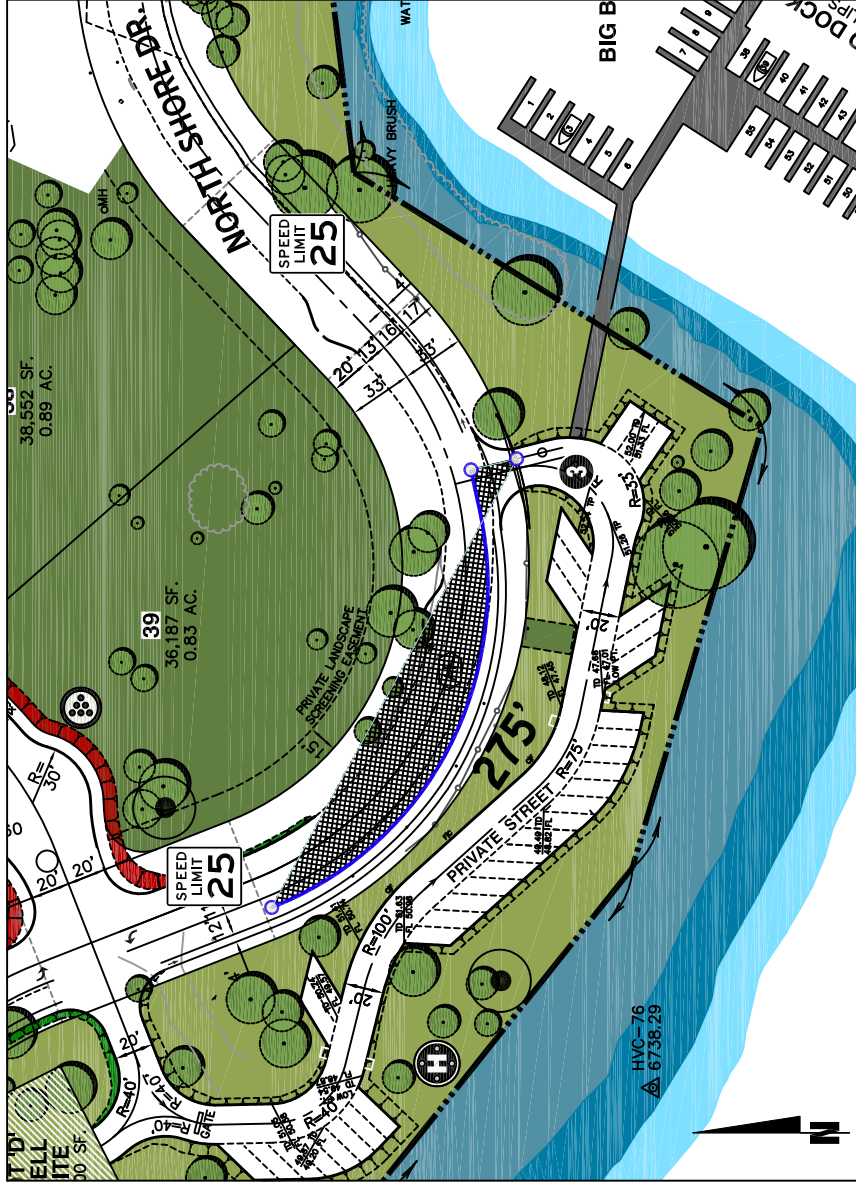

LEGEND:

 = MINIMUM SIGHT DISTANCE LINES

 = LIMITED USE AREA

(THERE SHALL BE NO OBSTRUCTION WITHIN THE LIMITED USE AREA. OBSTRUCTIONS INCLUDE, BUT NOT LIMITED TO, ANY SIGNS OR OBJECTS HIGHER THAN 2.5' MEASURED FROM PAVEMENT WITHIN THE AREA OF LIMITED USE.)

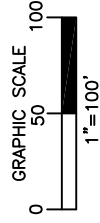
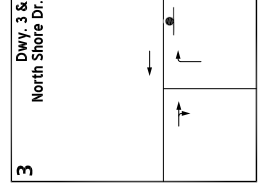

Table 3

Sunday (mid-day) Peak Hour Intersection Analysis, With Improvements

#	Intersection	Traffic Control ³	Intersection Approach Lanes ¹												Delay ² (secs.)	Level of Service
			Northbound			Southbound			Eastbound			Westbound				
			L	T	R	L	T	R	L	T	R	L	T	R		
1	Stanfield Cutoff / North Shore Drive (SR-38)															
	- Near-term (2021) Without Project, with improvements ⁵	<u>TS</u>	<u>1</u>	1	0	<u>1</u>	1	0	<u>1</u>	1	0	<u>1</u>	1	0	28.3	C
	- Near-term (2021) With Project, with improvements ⁵	<u>TS</u>	<u>1</u>	1	0	<u>1</u>	1	0	<u>1</u>	1	0	<u>1</u>	1	0	32.7	C
	- Horizon Year (2040) Without Project, with improvements ⁵	<u>TS</u>	<u>2</u>	1	0	<u>1</u>	1	0	<u>1</u>	1	<u>1></u>	<u>1</u>	1	0	19.7	B
	- Horizon Year (2040) With Project, with improvements ⁵	<u>TS</u>	<u>2</u>	1	0	<u>1</u>	1	0	<u>1</u>	1	<u>1></u>	<u>1</u>	1	0	19.7	B

¹ When a right turn is designated, the lane can either be striped or unstriped. To function as a right turn lane there must be sufficient width for right turning vehicles to travel outside the through lanes.

L = Left; T = Through; R = Right; 1> = Right turn overlap; 1 = Improvement

² Per the 2010 Highway Capacity Manual, overall average intersection delay and level of service are shown for intersections with a traffic signal or all way stop control. For intersections with cross street stop control, the delay and level of service for the worst individual movement (or movements sharing a single lane) are shown. The intersections have been analyzed using the Synchro software.

³ TS = Traffic Signal

⁴ With the proposed widening of Cherry Valley Boulevard to provide the eastbound left turn lane, it is anticipated that storage for up to two vehicles will be available in the painted median. Two-stage gap acceptance with up to 2 vehicles in median storage assumed for SBL turns from Calimesa Blvd.

⁵ Improvements are consistent with recommendations in Moon Camp Traffic Impact Analysis (June 29, 2007) prepared by Urban Crossroads, Inc.

TABLE 4
ROADWAY IMPROVEMENTS COST

INTERSECTION	2040 IMPROVEMENTS	2017 COST	Notes
North Shore Dr. (SR-38) (NS) at: • Big Bear Blvd. (SR-18) (EW)	Install Traffic Signal Construct NB Left Turn Lane Construct EB Through Lane Add Right Turn Overlap Phasing	-	Built Built Built
		\$25,000	
		\$25,000	
Standfield Cutoff (NS) at: • North Shore Dr. (EW)	Install Traffic Signal Construct 2 NB left turn lanes Construct SB left turn lane Construct EB left turn lane Construct EB right turn lane Add Right Turn Overlap Phasing Construct WB left turn lane	\$600,000	
		\$100,000	
		\$50,000	
		\$50,000	
		\$50,000	
		\$25,000	
		\$50,000	
		\$925,000	
Stanfield Cutoff (NS) at: • Big Bear Blvd. (EW)	Construct NB left turn lane Construct SB left turn lane Construct SB right turn lane Add Right Turn Overlap Phasing Construct EB through lane Construct WB through lane Signal Modification	\$50,000	
		\$50,000	
		\$50,000	
		\$25,000	
		\$300,000	
		\$300,000	
		\$40,000	
		\$815,000	
TOTAL - COST OF CONSTRUCTION		\$1,765,000	

TABLE 5

PROJECT FAIR SHARE

SEGMENT	COST	PEAK HOUR	EXISTING TRAFFIC	2040 WITH PROJECT TRAFFIC	PROJECT TRAFFIC	TOTAL NEW TRAFFIC	PROJECT % OF NEW TRAFFIC	(A) FRIDAY PM PROJECT COST SHARE	(B) SUNDAY MID. PROJECT COST SHARE	HIGHEST FRIDAY PM OR SUNDAY MID. COST SHARE
North Shore Dr. (SR-38) (NS) at: • Big Bear Blvd. (EW)	\$25,000	Friday PM	733	1,047	16	314	5.10%	\$1,274	\$1,498	\$1,498
		Sunday Midday	1026	1,460	26	434	5.99%			
Standfield Cutoff (NS) at: • North Shore Dr. (EW)	\$925,000	Friday PM	816	1,261	36	445	8.09%	\$74,831	\$71,577	\$74,831
		Sunday Midday	1,035	1,371	26	336	7.74%			
Stanfield Cutoff (NS) at: • Big Bear Blvd. (EW)	\$815,000	Friday PM	2,413	3,441	29	1,028	2.82%	\$22,991	\$16,649	\$22,991
		Sunday Midday	2,436	3,464	21	1,028	2.04%			
GRAND TOTAL - COST SHARE FOR IMPROVEMENTS								\$99,097	\$89,724	\$99,320

ATTACHMENT A:

2016 COUNT DATA

Count Comparison

Friday PM

1: North Shore Drive / Big Bear Boulevard

	<u>NBL</u>	<u>NBT</u>	<u>NBR</u>	<u>SBL</u>	<u>SBT</u>	<u>SBR</u>	<u>EBL</u>	<u>EBT</u>	<u>EBR</u>	<u>WBL</u>	<u>WBT</u>	<u>WBR</u>	<u>TOTAL</u>
Existing 2007:	0	0	0	22	0	26	87	298	0	0	315	21	769
Existing 2016:	0	0	0	17	0	32	84	314	0	0	132	21	600
Variance:	0	0	0	-5	0	6	-3	16	0	0	-183	0	-169
% Difference:	0.0%	0.0%	0.0%	-22.7%	0.0%	23.1%	-3.4%	5.4%	0.0%	0.0%	-58.1%	0.0%	-22.0%

2: Stanfield Cutoff / North Shore Drive

	<u>NBL</u>	<u>NBT</u>	<u>NBR</u>	<u>SBL</u>	<u>SBT</u>	<u>SBR</u>	<u>EBL</u>	<u>EBT</u>	<u>EBR</u>	<u>WBL</u>	<u>WBT</u>	<u>WBR</u>	<u>TOTAL</u>
Existing 2007:	57	5	205	5	10	0	0	71	70	215	52	6	696
Existing 2016:	80	7	165	5	6	0	0	70	102	177	73	1	686
Variance:	23	2	-40	0	-4	0	0	-1	32	-38	21	-5	-10
% Difference:	40.4%	40.0%	-19.5%	0.0%	-40.0%	0.0%	0.0%	-1.4%	45.7%	-17.7%	40.4%	-83.3%	-1.4%

3: Stanfield Cutoff / Big Bear Boulevard

	<u>NBL</u>	<u>NBT</u>	<u>NBR</u>	<u>SBL</u>	<u>SBT</u>	<u>SBR</u>	<u>EBL</u>	<u>EBT</u>	<u>EBR</u>	<u>WBL</u>	<u>WBT</u>	<u>WBR</u>	<u>TOTAL</u>
Existing 2007:	61	18	60	12	28	254	283	865	76	17	655	13	2,342
Existing 2016:	38	35	54	11	22	247	232	721	41	25	561	24	2,011
Variance:	-23	17	-6	-1	-6	-7	-51	-144	-35	8	-94	11	-331
% Difference:	-37.7%	94.4%	-10.0%	-8.3%	-21.4%	-2.8%	-18.0%	-16.6%	-46.1%	47.1%	-14.4%	84.6%	-14.1%

Count Comparison

Sunday

1: North Shore Drive / Big Bear Boulevard

	<u>NBL</u>	<u>NBT</u>	<u>NBR</u>	<u>SBL</u>	<u>SBT</u>	<u>SBR</u>	<u>EBL</u>	<u>EBT</u>	<u>EBR</u>	<u>WBL</u>	<u>WBT</u>	<u>WBR</u>	<u>TOTAL</u>
Existing 2007:	0	0	0	40	0	93	66	411	0	0	954	33	1,597
Existing 2016:	0	0	0	47	0	112	52	212	0	0	395	59	877
Variance:	0	0	0	7	0	19	-14	-199	0	0	-559	26	-720
% Difference:	0.0%	0.0%	0.0%	17.5%	0.0%	20.4%	-21.2%	-48.4%	0.0%	0.0%	-58.6%	78.8%	-45.1%

2: Stanfield Cutoff / North Shore Drive

	<u>NBL</u>	<u>NBT</u>	<u>NBR</u>	<u>SBL</u>	<u>SBT</u>	<u>SBR</u>	<u>EBL</u>	<u>EBT</u>	<u>EBR</u>	<u>WBL</u>	<u>WBT</u>	<u>WBR</u>	<u>TOTAL</u>
Existing 2007:	109	4	174	8	6	6	4	80	119	177	82	6	775
Existing 2016:	152	8	155	12	2	3	0	92	140	200	98	6	868
Variance:	43	4	-19	4	-4	-3	-4	12	21	23	16	0	93
% Difference:	39.4%	100.0%	-10.9%	50.0%	-66.7%	0.0%	0.0%	15.0%	17.6%	13.0%	19.5%	0.0%	12.0%

3: Stanfield Cutoff / Big Bear Boulevard

	<u>NBL</u>	<u>NBT</u>	<u>NBR</u>	<u>SBL</u>	<u>SBT</u>	<u>SBR</u>	<u>EBL</u>	<u>EBT</u>	<u>EBR</u>	<u>WBL</u>	<u>WBT</u>	<u>WBR</u>	<u>TOTAL</u>
Existing 2007:	63	39	69	21	34	264	229	803	48	36	633	22	2,261
Existing 2016:	43	32	45	24	29	297	278	681	30	27	563	25	2,074
Variance:	-20	-7	-24	3	-5	33	49	-122	-18	-9	-70	3	-187
% Difference:	-31.7%	-17.9%	-34.8%	14.3%	-14.7%	12.5%	21.4%	-15.2%	-37.5%	-25.0%	-11.1%	13.6%	-8.3%

County of San Bernardino
 N/S: North Shore Drive (SR-38)
 E/W: SR-18 (Big Bear Boulevard)
 Weather: Clear

File Name : CSBSH18PM
 Site Code : 05116469
 Start Date : 9/9/2016
 Page No : 1

Groups Printed- Passenger Vehicles - Large 2 Axle Vehicles - 3 Axle Vehicles - 4+ Axle Trucks

Start Time	North Shore Drive Southbound				SR-18 Westbound				SR-18 Eastbound				Exclu. Total	Inclu. Total	Int. Total
	Left	Right	RTOR	App. Total	Thru	Right	RTOR	App. Total	Left	Thru	RTOR	App. Total			
04:00 PM	1	8	5	9	32	4	0	36	33	102	0	135	5	180	185
04:15 PM	8	6	6	14	29	3	0	32	9	43	0	52	6	98	104
04:30 PM	1	14	10	15	42	8	0	50	30	113	0	143	10	208	218
04:45 PM	7	4	4	11	29	6	0	35	12	56	0	68	4	114	118
Total	17	32	25	49	132	21	0	153	84	314	0	398	25	600	625
05:00 PM	6	7	5	13	30	6	0	36	12	78	0	90	5	139	144
05:15 PM	3	19	5	22	30	5	0	35	10	72	0	82	5	139	144
05:30 PM	8	7	1	15	26	4	0	30	14	43	0	57	1	102	103
05:45 PM	1	6	5	7	32	3	0	35	18	75	0	93	5	135	140
Total	18	39	16	57	118	18	0	136	54	268	0	322	16	515	531
Grand Total	35	71	41	106	250	39	0	289	138	582	0	720	41	1115	1156
Apprch %	33	67			86.5	13.5			19.2	80.8					
Total %	3.1	6.4		9.5	22.4	3.5		25.9	12.4	52.2		64.6	3.5	96.5	
Passenger Vehicles	35	70		146	231	39		270	136	573		709	0	0	1125
% Passenger Vehicles	100	98.6	100	99.3	92.4	100	0	93.4	98.6	98.5	0	98.5	0	0	97.3
Large 2 Axle Vehicles	0	1		1	14	0		14	2	7		9	0	0	24
% Large 2 Axle Vehicles	0	1.4	0	0.7	5.6	0	0	4.8	1.4	1.2	0	1.2	0	0	2.1
3 Axle Vehicles	0	0		0	1	0		1	0	1		1	0	0	2
% 3 Axle Vehicles	0	0	0	0	0.4	0	0	0.3	0	0.2	0	0.1	0	0	0.2
4+ Axle Trucks	0	0		0	4	0		4	0	1		1	0	0	5
% 4+ Axle Trucks	0	0	0	0	1.6	0	0	1.4	0	0.2	0	0.1	0	0	0.4

Start Time	North Shore Drive Southbound			SR-18 Westbound			SR-18 Eastbound			Int. Total
	Left	Right	App. Total	Thru	Right	App. Total	Left	Thru	App. Total	
Peak Hour Analysis From 04:00 PM to 05:45 PM - Peak 1 of 1										
Peak Hour for Entire Intersection Begins at 04:00 PM										
04:00 PM	1	8	9	32	4	36	33	102	135	180
04:15 PM	8	6	14	29	3	32	9	43	52	98
04:30 PM	1	14	15	42	8	50	30	113	143	208
04:45 PM	7	4	11	29	6	35	12	56	68	114
Total Volume	17	32	49	132	21	153	84	314	398	600
% App. Total	34.7	65.3		86.3	13.7		21.1	78.9		
PHF	.531	.571	.817	.786	.656	.765	.636	.695	.696	.721

County of San Bernardino
 N/S: North Shore Drive (SR-38)
 E/W: SR-18 (Big Bear Boulevard)
 Weather: Clear

File Name : CSBSH18PM
 Site Code : 05116469
 Start Date : 9/9/2016
 Page No : 2

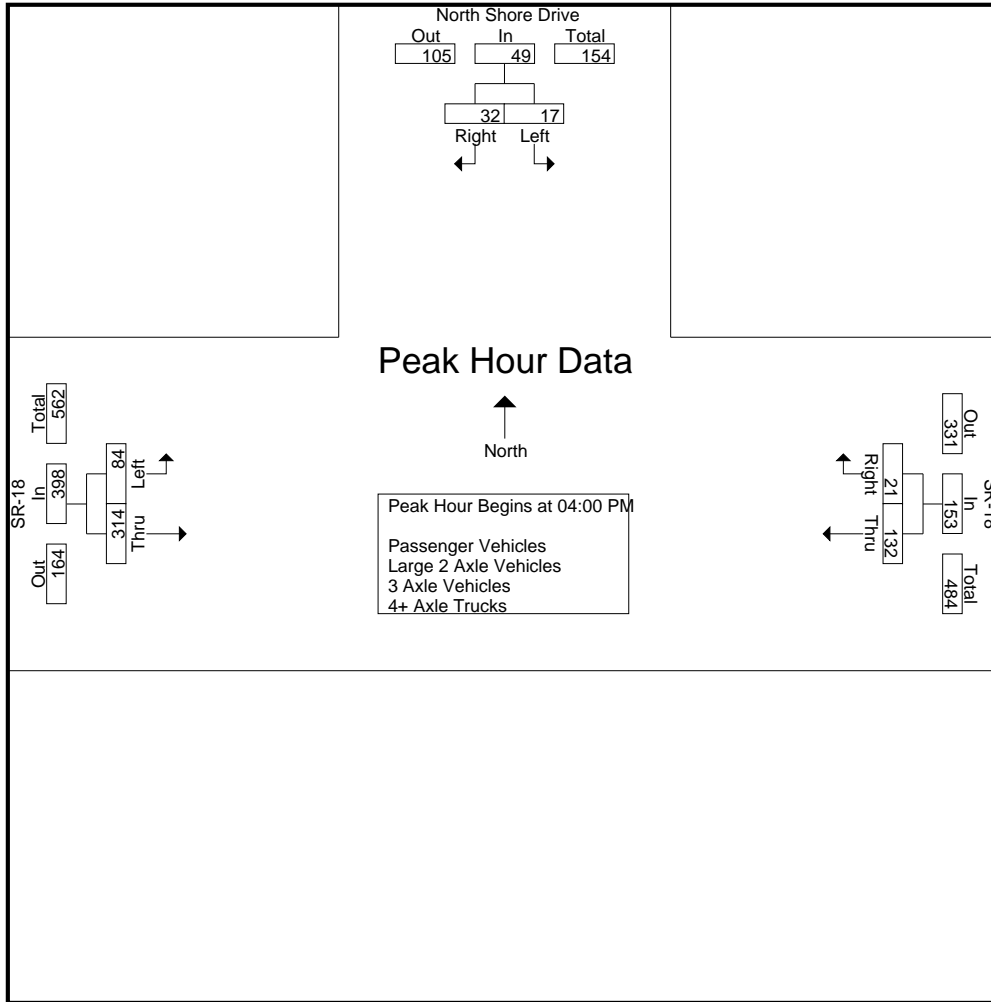

Peak Hour Analysis From 04:00 PM to 05:45 PM - Peak 1 of 1
 Peak Hour for Each Approach Begins at:

	04:30 PM			04:30 PM			04:00 PM		
+0 mins.	1	14	15	42	8	50	33	102	135
+15 mins.	7	4	11	29	6	35	9	43	52
+30 mins.	6	7	13	30	6	36	30	113	143
+45 mins.	3	19	22	30	5	35	12	56	68
Total Volume	17	44	61	131	25	156	84	314	398
% App. Total	27.9	72.1		84	16		21.1	78.9	
PHF	.607	.579	.693	.780	.781	.780	.636	.695	.696

County of San Bernardino
 N/S: North Shore Drive (SR-38)
 E/W: SR-18 (Big Bear Boulevard)
 Weather: Clear

File Name : CSBSH18PM
 Site Code : 05116469
 Start Date : 9/9/2016
 Page No : 1

Groups Printed- Passenger Vehicles

Start Time	North Shore Drive Southbound				SR-18 Westbound				SR-18 Eastbound				Exclu. Total	Inclu. Total	Int. Total
	Left	Right	RTOR	App. Total	Thru	Right	RTOR	App. Total	Left	Thru	RTOR	App. Total			
04:00 PM	1	8	5	9	28	4	0	32	33	98	0	131	5	172	177
04:15 PM	8	6	6	14	27	3	0	30	9	43	0	52	6	96	102
04:30 PM	1	14	10	15	39	8	0	47	30	112	0	142	10	204	214
04:45 PM	7	4	4	11	26	6	0	32	12	56	0	68	4	111	115
Total	17	32	25	49	120	21	0	141	84	309	0	393	25	583	608
05:00 PM	6	7	5	13	28	6	0	34	10	77	0	87	5	134	139
05:15 PM	3	19	5	22	30	5	0	35	10	70	0	80	5	137	142
05:30 PM	8	7	1	15	24	4	0	28	14	43	0	57	1	100	101
05:45 PM	1	5	5	6	29	3	0	32	18	74	0	92	5	130	135
Total	18	38	16	56	111	18	0	129	52	264	0	316	16	501	517
Grand Total	35	70	41	105	231	39	0	270	136	573	0	709	41	1084	1125
Apprch %	33.3	66.7			85.6	14.4			19.2	80.8					
Total %	3.2	6.5		9.7	21.3	3.6		24.9	12.5	52.9		65.4	3.6	96.4	

Start Time	North Shore Drive Southbound			SR-18 Westbound			SR-18 Eastbound			Int. Total
	Left	Right	App. Total	Thru	Right	App. Total	Left	Thru	App. Total	
04:00 PM	1	8	9	28	4	32	33	98	131	172
04:15 PM	8	6	14	27	3	30	9	43	52	96
04:30 PM	1	14	15	39	8	47	30	112	142	204
04:45 PM	7	4	11	26	6	32	12	56	68	111
Total Volume	17	32	49	120	21	141	84	309	393	583
% App. Total	34.7	65.3		85.1	14.9		21.4	78.6		
PHF	.531	.571	.817	.769	.656	.750	.636	.690	.692	.714

Peak Hour Analysis From 04:00 PM to 04:45 PM - Peak 1 of 1
 Peak Hour for Entire Intersection Begins at 04:00 PM

County of San Bernardino
 N/S: North Shore Drive (SR-38)
 E/W: SR-18 (Big Bear Boulevard)
 Weather: Clear

File Name : CSBSH18PM
 Site Code : 05116469
 Start Date : 9/9/2016
 Page No : 2

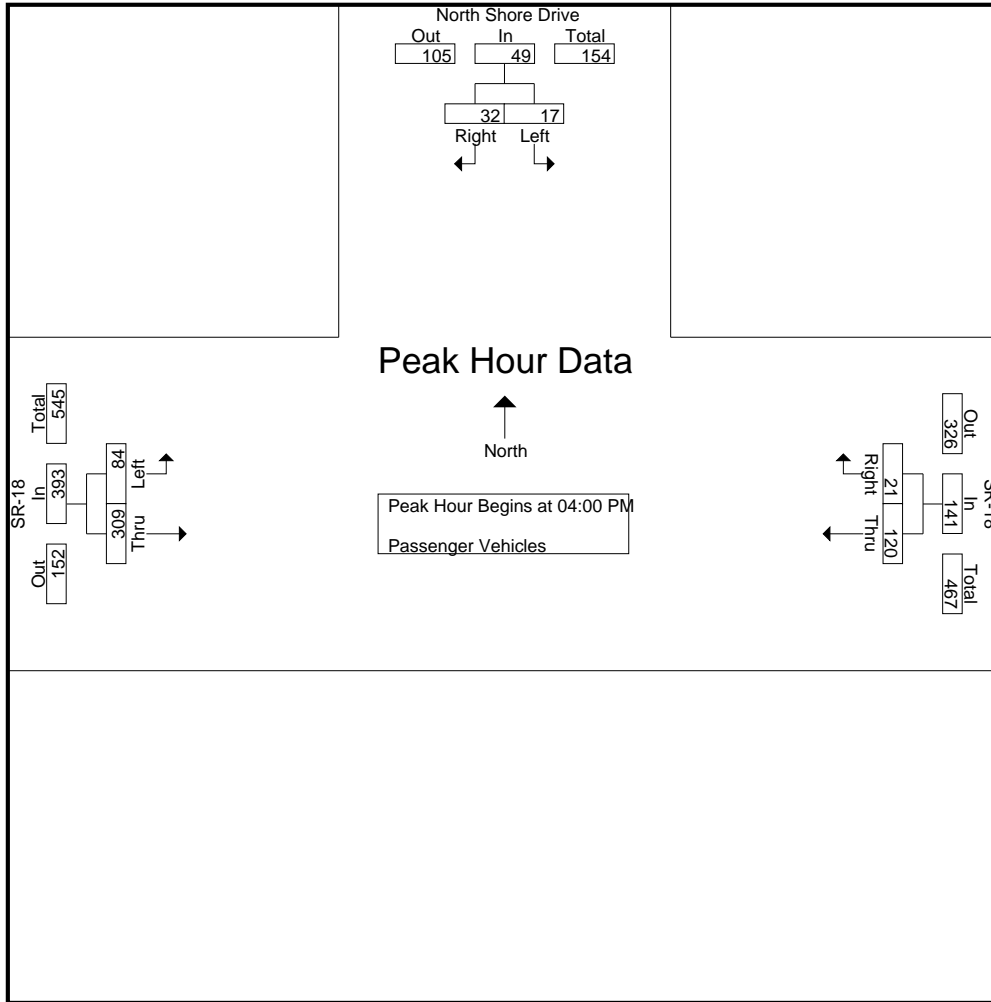

Peak Hour Analysis From 04:00 PM to 04:45 PM - Peak 1 of 1
 Peak Hour for Each Approach Begins at:

	04:00 PM			04:00 PM			04:00 PM		
+0 mins.	1	8	9	28	4	32	33	98	131
+15 mins.	8	6	14	27	3	30	9	43	52
+30 mins.	1	14	15	39	8	47	30	112	142
+45 mins.	7	4	11	26	6	32	12	56	68
Total Volume	17	32	49	120	21	141	84	309	393
% App. Total	34.7	65.3		85.1	14.9		21.4	78.6	
PHF	.531	.571	.817	.769	.656	.750	.636	.690	.692

County of San Bernardino
 N/S: North Shore Drive (SR-38)
 E/W: SR-18 (Big Bear Boulevard)
 Weather: Clear

File Name : CSBSH18PM
 Site Code : 05116469
 Start Date : 9/9/2016
 Page No : 1

Groups Printed- Large 2 Axle Vehicles

Start Time	North Shore Drive Southbound				SR-18 Westbound				SR-18 Eastbound				Exclu. Total	Inclu. Total	Int. Total
	Left	Right	RTOR	App. Total	Thru	Right	RTOR	App. Total	Left	Thru	RTOR	App. Total			
04:00 PM	0	0	0	0	3	0	0	3	0	2	0	2	0	5	5
04:15 PM	0	0	0	0	1	0	0	1	0	0	0	0	0	1	1
04:30 PM	0	0	0	0	1	0	0	1	0	1	0	1	0	2	2
04:45 PM	0	0	0	0	3	0	0	3	0	0	0	0	0	3	3
Total	0	0	0	0	8	0	0	8	0	3	0	3	0	11	11
05:00 PM	0	0	0	0	2	0	0	2	2	1	0	3	0	5	5
05:15 PM	0	0	0	0	0	0	0	0	0	2	0	2	0	2	2
05:30 PM	0	0	0	0	2	0	0	2	0	0	0	0	0	2	2
05:45 PM	0	1	0	1	2	0	0	2	0	1	0	1	0	4	4
Total	0	1	0	1	6	0	0	6	2	4	0	6	0	13	13
Grand Total	0	1	0	1	14	0	0	14	2	7	0	9	0	24	24
Apprch %	0	100			100	0			22.2	77.8					
Total %	0	4.2		4.2	58.3	0		58.3	8.3	29.2		37.5	0	100	

Start Time	North Shore Drive Southbound			SR-18 Westbound			SR-18 Eastbound			Int. Total
	Left	Right	App. Total	Thru	Right	App. Total	Left	Thru	App. Total	
04:00 PM	0	0	0	3	0	3	0	2	2	5
04:15 PM	0	0	0	1	0	1	0	0	0	1
04:30 PM	0	0	0	1	0	1	0	1	1	2
04:45 PM	0	0	0	3	0	3	0	0	0	3
Total Volume	0	0	0	8	0	8	0	3	3	11
% App. Total	0	0		100	0		0	100		
PHF	.000	.000	.000	.667	.000	.667	.000	.375	.375	.550

Peak Hour Analysis From 04:00 PM to 04:45 PM - Peak 1 of 1
 Peak Hour for Entire Intersection Begins at 04:00 PM

County of San Bernardino
 N/S: North Shore Drive (SR-38)
 E/W: SR-18 (Big Bear Boulevard)
 Weather: Clear

File Name : CSBSH18PM
 Site Code : 05116469
 Start Date : 9/9/2016
 Page No : 2

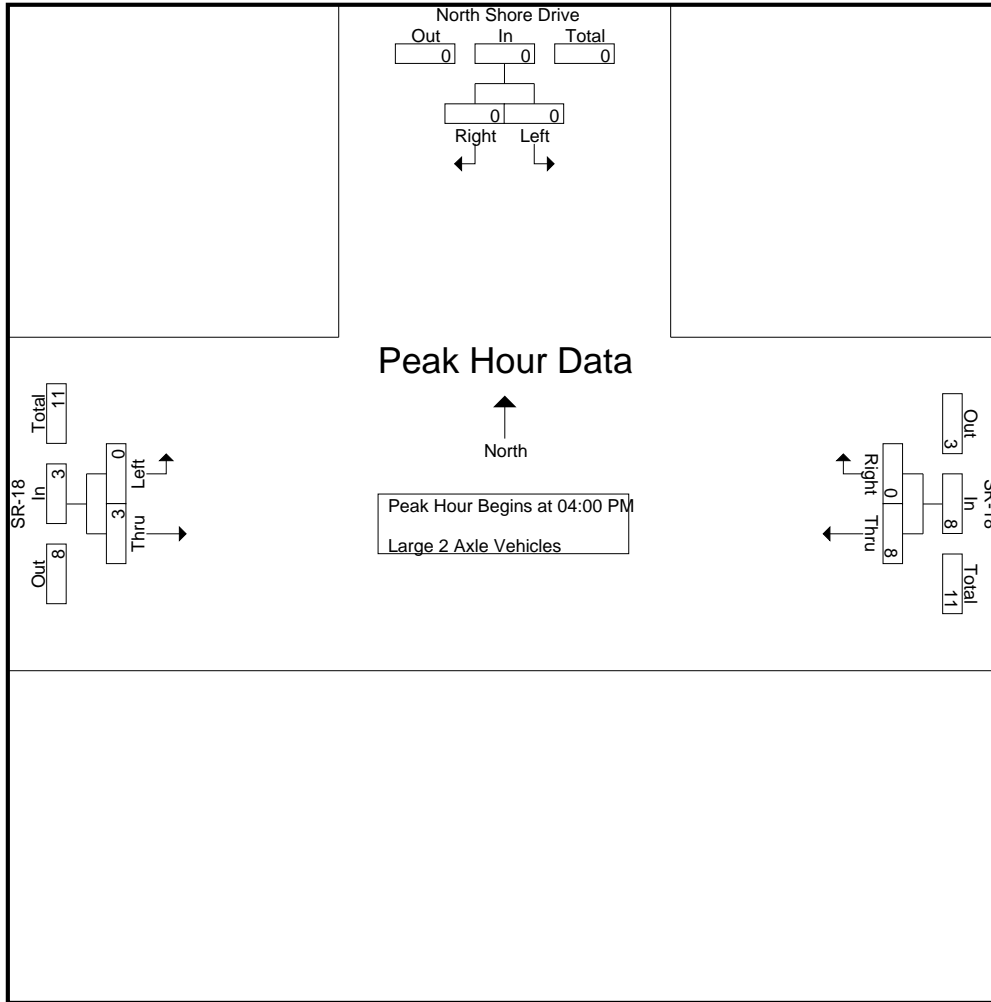

Peak Hour Analysis From 04:00 PM to 04:45 PM - Peak 1 of 1
 Peak Hour for Each Approach Begins at:

	04:00 PM			04:00 PM			04:00 PM		
+0 mins.	0	0	0	3	0	3	0	2	2
+15 mins.	0	0	0	1	0	1	0	0	0
+30 mins.	0	0	0	1	0	1	0	1	1
+45 mins.	0	0	0	3	0	3	0	0	0
Total Volume	0	0	0	8	0	8	0	3	3
% App. Total	0	0	0	100	0	100	0	100	
PHF	.000	.000	.000	.667	.000	.667	.000	.375	.375

County of San Bernardino
 N/S: North Shore Drive (SR-38)
 E/W: SR-18 (Big Bear Boulevard)
 Weather: Clear

File Name : CSBSH18PM
 Site Code : 05116469
 Start Date : 9/9/2016
 Page No : 1

Groups Printed- 3 Axle Vehicles

Start Time	North Shore Drive Southbound				SR-18 Westbound				SR-18 Eastbound				Exclu. Total	Inclu. Total	Int. Total
	Left	Right	RTOR	App. Total	Thru	Right	RTOR	App. Total	Left	Thru	RTOR	App. Total			
04:00 PM	0	0	0	0	0	0	0	0	0	1	0	1	0	1	1
04:15 PM	0	0	0	0	0	0	0	0	0	0	0	0	0	0	0
04:30 PM	0	0	0	0	1	0	0	1	0	0	0	0	0	1	1
04:45 PM	0	0	0	0	0	0	0	0	0	0	0	0	0	0	0
Total	0	0	0	0	1	0	0	1	0	1	0	1	0	2	2
05:00 PM	0	0	0	0	0	0	0	0	0	0	0	0	0	0	0
05:15 PM	0	0	0	0	0	0	0	0	0	0	0	0	0	0	0
05:30 PM	0	0	0	0	0	0	0	0	0	0	0	0	0	0	0
05:45 PM	0	0	0	0	0	0	0	0	0	0	0	0	0	0	0
Total	0	0	0	0	0	0	0	0	0	0	0	0	0	0	0
Grand Total	0	0	0	0	1	0	0	1	0	1	0	1	0	2	2
Apprch %	0	0			100	0			0	100					
Total %	0	0			50	0		50	0	50		50	0	100	

Start Time	North Shore Drive Southbound			SR-18 Westbound			SR-18 Eastbound			Int. Total
	Left	Right	App. Total	Thru	Right	App. Total	Left	Thru	App. Total	
04:00 PM	0	0	0	0	0	0	0	1	1	1
04:15 PM	0	0	0	0	0	0	0	0	0	0
04:30 PM	0	0	0	1	0	1	0	0	0	1
04:45 PM	0	0	0	0	0	0	0	0	0	0
Total Volume	0	0	0	1	0	1	0	1	1	2
% App. Total	0	0		100	0		0	100		
PHF	.000	.000	.000	.250	.000	.250	.000	.250	.250	.500

Peak Hour Analysis From 04:00 PM to 04:45 PM - Peak 1 of 1
 Peak Hour for Entire Intersection Begins at 04:00 PM

County of San Bernardino
 N/S: North Shore Drive (SR-38)
 E/W: SR-18 (Big Bear Boulevard)
 Weather: Clear

File Name : CSBSH18PM
 Site Code : 05116469
 Start Date : 9/9/2016
 Page No : 2

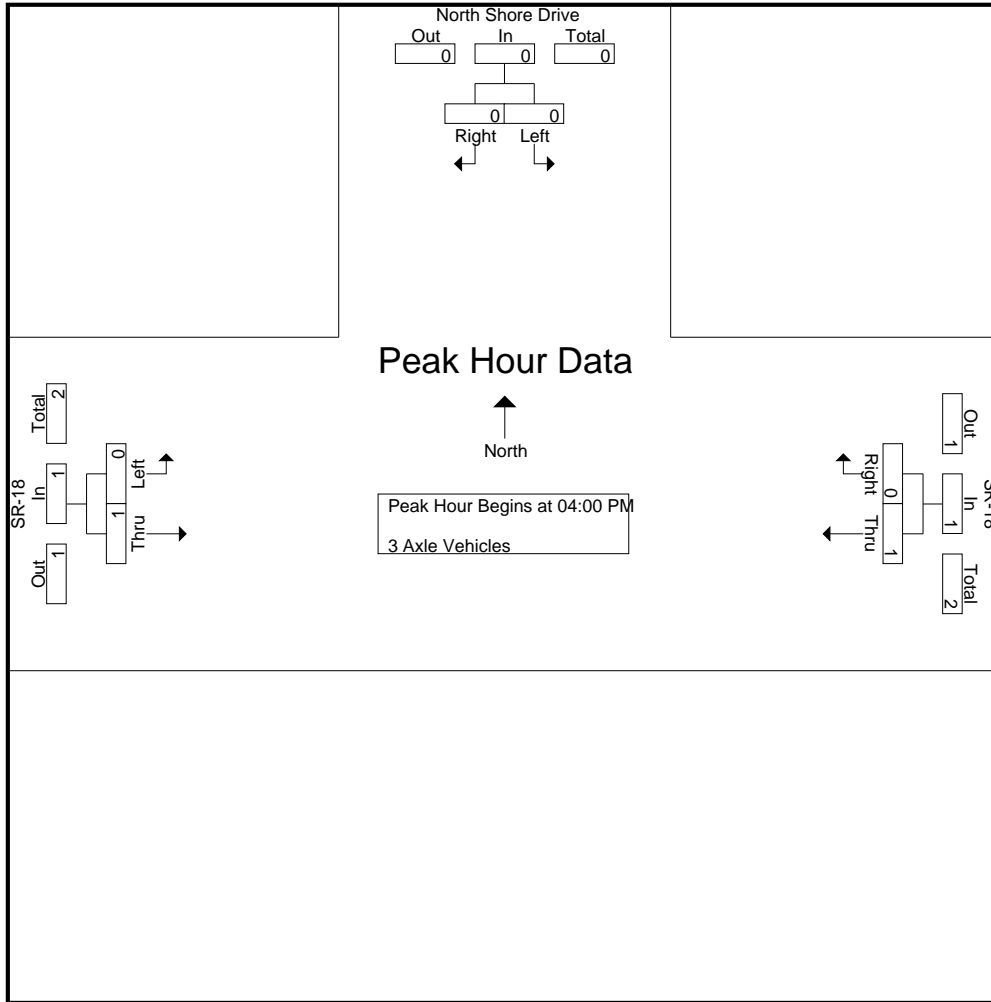

Peak Hour Analysis From 04:00 PM to 04:45 PM - Peak 1 of 1
 Peak Hour for Each Approach Begins at:

	04:00 PM			04:00 PM			04:00 PM		
+0 mins.	0	0	0	0	0	0	0	1	1
+15 mins.	0	0	0	0	0	0	0	0	0
+30 mins.	0	0	0	1	0	1	0	0	0
+45 mins.	0	0	0	0	0	0	0	0	0
Total Volume	0	0	0	1	0	1	0	1	1
% App. Total	0	0	0	100	0	100	0	100	100
PHF	.000	.000	.000	.250	.000	.250	.000	.250	.250

County of San Bernardino
 N/S: North Shore Drive (SR-38)
 E/W: SR-18 (Big Bear Boulevard)
 Weather: Clear

File Name : CSBSH18PM
 Site Code : 05116469
 Start Date : 9/9/2016
 Page No : 1

Groups Printed- 4+ Axle Trucks

Start Time	North Shore Drive Southbound				SR-18 Westbound				SR-18 Eastbound				Exclu. Total	Inclu. Total	Int. Total
	Left	Right	RTOR	App. Total	Thru	Right	RTOR	App. Total	Left	Thru	RTOR	App. Total			
04:00 PM	0	0	0	0	1	0	0	1	0	1	0	1	0	2	2
04:15 PM	0	0	0	0	1	0	0	1	0	0	0	0	0	1	1
04:30 PM	0	0	0	0	1	0	0	1	0	0	0	0	0	1	1
04:45 PM	0	0	0	0	0	0	0	0	0	0	0	0	0	0	0
Total	0	0	0	0	3	0	0	3	0	1	0	1	0	4	4
05:00 PM	0	0	0	0	0	0	0	0	0	0	0	0	0	0	0
05:15 PM	0	0	0	0	0	0	0	0	0	0	0	0	0	0	0
05:30 PM	0	0	0	0	0	0	0	0	0	0	0	0	0	0	0
05:45 PM	0	0	0	0	1	0	0	1	0	0	0	0	0	1	1
Total	0	0	0	0	1	0	0	1	0	0	0	0	0	1	1
Grand Total	0	0	0	0	4	0	0	4	0	1	0	1	0	5	5
Apprch %	0	0			100	0			0	100					
Total %	0	0			80	0		80	0	20		20	0	100	

Start Time	North Shore Drive Southbound			SR-18 Westbound			SR-18 Eastbound			Int. Total
	Left	Right	App. Total	Thru	Right	App. Total	Left	Thru	App. Total	
04:00 PM	0	0	0	1	0	1	0	1	1	2
04:15 PM	0	0	0	1	0	1	0	0	0	1
04:30 PM	0	0	0	1	0	1	0	0	0	1
04:45 PM	0	0	0	0	0	0	0	0	0	0
Total Volume	0	0	0	3	0	3	0	1	1	4
% App. Total	0	0		100	0		0	100		
PHF	.000	.000	.000	.750	.000	.750	.000	.250	.250	.500

Peak Hour Analysis From 04:00 PM to 04:45 PM - Peak 1 of 1
 Peak Hour for Entire Intersection Begins at 04:00 PM

County of San Bernardino
 N/S: North Shore Drive (SR-38)
 E/W: SR-18 (Big Bear Boulevard)
 Weather: Clear

File Name : CSBSH18PM
 Site Code : 05116469
 Start Date : 9/9/2016
 Page No : 2

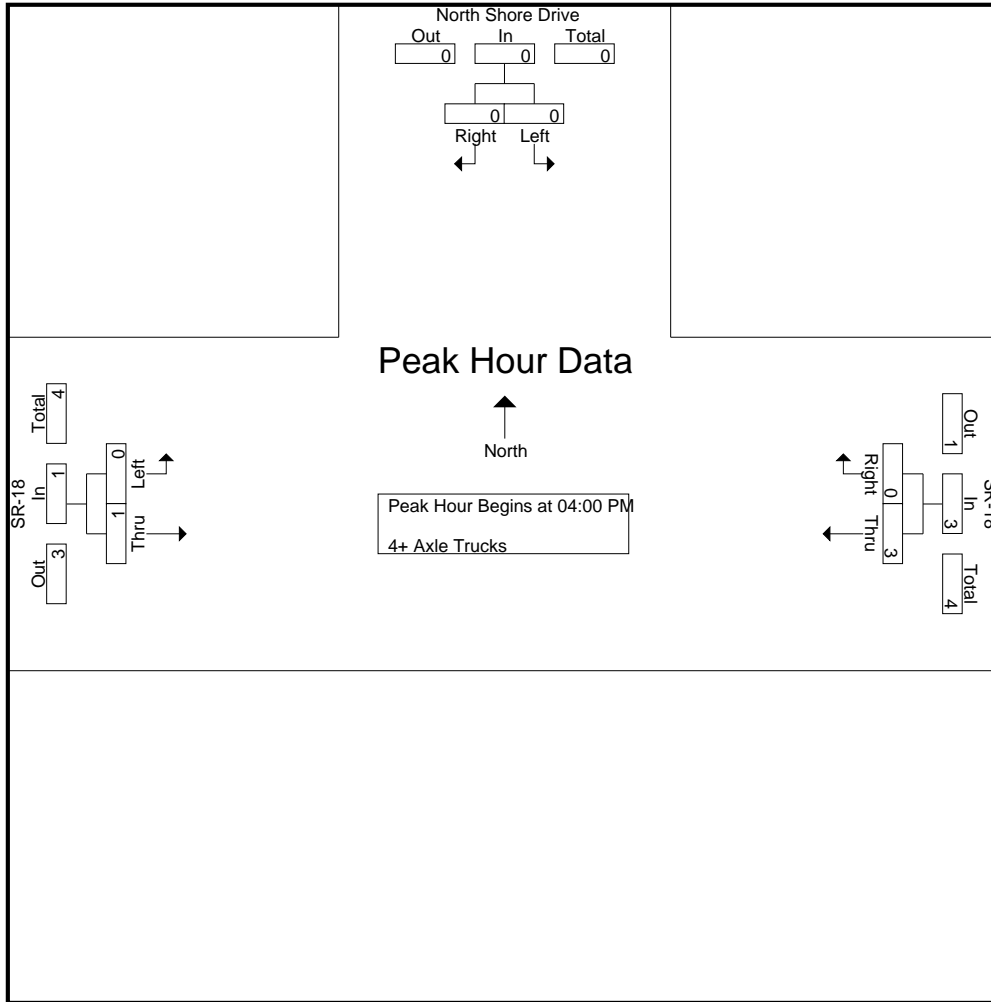

Peak Hour Analysis From 04:00 PM to 04:45 PM - Peak 1 of 1
 Peak Hour for Each Approach Begins at:

	04:00 PM			04:00 PM			04:00 PM		
+0 mins.	0	0	0	1	0	1	0	1	1
+15 mins.	0	0	0	1	0	1	0	0	0
+30 mins.	0	0	0	1	0	1	0	0	0
+45 mins.	0	0	0	0	0	0	0	0	0
Total Volume	0	0	0	3	0	3	0	1	1
% App. Total	0	0	0	100	0	100	0	100	100
PHF	.000	.000	.000	.750	.000	.750	.000	.250	.250

County of San Bernardino
 N/S: North Shore Drive (SR-38)
 E/W: SR-18 (Big Bear Boulevard)
 Weather: Clear

File Name : CSBSH18SUN
 Site Code : 05116469
 Start Date : 9/11/2016
 Page No : 1

Groups Printed- Passenger Vehicles - Large 2 Axle Vehicles - 3 Axle Vehicles - 4+ Axle Trucks

Start Time	North Shore Drive Southbound				SR-18 Westbound				SR-18 Eastbound				Exclu. Total	Inclu. Total	Int. Total
	Left	Right	RTOR	App. Total	Thru	Right	RTOR	App. Total	Left	Thru	RTOR	App. Total			
12:00 PM	8	33	17	41	90	12	4	102	14	56	0	70	21	213	234
12:15 PM	13	31	7	44	105	13	0	118	16	55	0	71	7	233	240
12:30 PM	13	26	20	39	102	16	0	118	13	48	0	61	20	218	238
12:45 PM	13	22	3	35	98	18	1	116	9	53	0	62	4	213	217
Total	47	112	47	159	395	59	5	454	52	212	0	264	52	877	929
01:00 PM	8	32	9	40	97	13	0	110	12	41	0	53	9	203	212
01:15 PM	10	35	10	45	83	14	0	97	13	51	0	64	10	206	216
01:30 PM	9	44	22	53	108	14	0	122	16	42	0	58	22	233	255
01:45 PM	12	28	10	40	101	13	1	114	14	54	0	68	11	222	233
Total	39	139	51	178	389	54	1	443	55	188	0	243	52	864	916
Grand Total	86	251	98	337	784	113	6	897	107	400	0	507	104	1741	1845
Apprch %	25.5	74.5			87.4	12.6			21.1	78.9					
Total %	4.9	14.4		19.4	45	6.5		51.5	6.1	23		29.1	5.6	94.4	
Passenger Vehicles	85	251		434	778	113		897	104	399		503	0	0	1834
% Passenger Vehicles	98.8	100	100	99.8	99.2	100	100	99.3	97.2	99.8	0	99.2	0	0	99.4
Large 2 Axle Vehicles	1	0		1	5	0		5	3	0		3	0	0	9
% Large 2 Axle Vehicles	1.2	0	0	0.2	0.6	0	0	0.6	2.8	0	0	0.6	0	0	0.5
3 Axle Vehicles	0	0		0	0	0		0	0	1		1	0	0	1
% 3 Axle Vehicles	0	0	0	0	0	0	0	0	0	0.2	0	0.2	0	0	0.1
4+ Axle Trucks	0	0		0	1	0		1	0	0		0	0	0	1
% 4+ Axle Trucks	0	0	0	0	0.1	0	0	0.1	0	0	0	0	0	0	0.1

Start Time	North Shore Drive Southbound			SR-18 Westbound			SR-18 Eastbound			Int. Total
	Left	Right	App. Total	Thru	Right	App. Total	Left	Thru	App. Total	
12:00 PM	8	33	41	90	12	102	14	56	70	213
12:15 PM	13	31	44	105	13	118	16	55	71	233
12:30 PM	13	26	39	102	16	118	13	48	61	218
12:45 PM	13	22	35	98	18	116	9	53	62	217
Total Volume	47	112	159	395	59	454	52	212	264	877
% App. Total	29.6	70.4		87	13		19.7	80.3		
PHF	.904	.848	.903	.940	.819	.962	.813	.946	.930	.941

Peak Hour Analysis From 12:00 PM to 01:45 PM - Peak 1 of 1
 Peak Hour for Entire Intersection Begins at 12:00 PM

County of San Bernardino
 N/S: North Shore Drive (SR-38)
 E/W: SR-18 (Big Bear Boulevard)
 Weather: Clear

File Name : CSBSH18SUN
 Site Code : 05116469
 Start Date : 9/11/2016
 Page No : 2

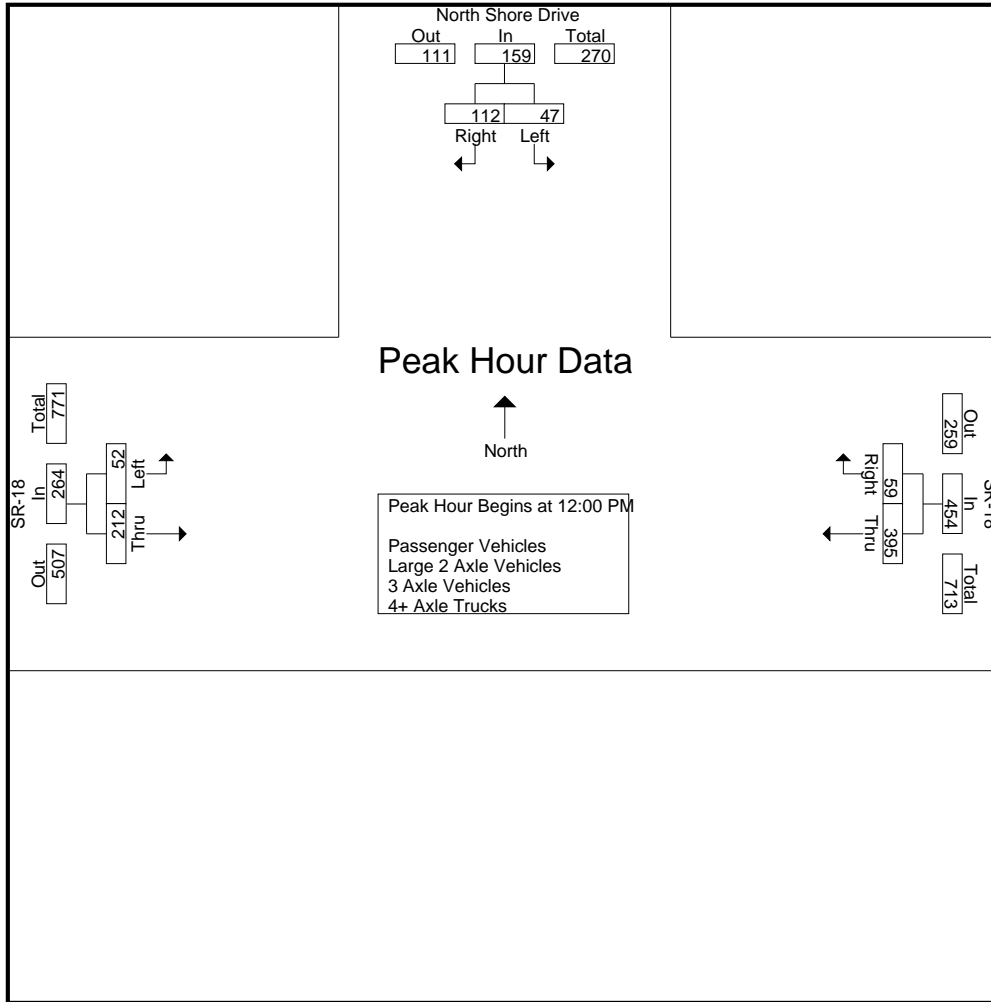

Peak Hour Analysis From 12:00 PM to 01:45 PM - Peak 1 of 1
 Peak Hour for Each Approach Begins at:

	01:00 PM			12:15 PM			12:00 PM		
+0 mins.	8	32	40	105	13	118	14	56	70
+15 mins.	10	35	45	102	16	118	16	55	71
+30 mins.	9	44	53	98	18	116	13	48	61
+45 mins.	12	28	40	97	13	110	9	53	62
Total Volume	39	139	178	402	60	462	52	212	264
% App. Total	21.9	78.1		87	13		19.7	80.3	
PHF	.813	.790	.840	.957	.833	.979	.813	.946	.930

County of San Bernardino
 N/S: North Shore Drive (SR-38)
 E/W: SR-18 (Big Bear Boulevard)
 Weather: Clear

File Name : CSBSH18SUN
 Site Code : 05116469
 Start Date : 9/11/2016
 Page No : 1

Groups Printed- Passenger Vehicles

Start Time	North Shore Drive Southbound				SR-18 Westbound				SR-18 Eastbound				Exclu. Total	Inclu. Total	Int. Total
	Left	Right	RTOR	App. Total	Thru	Right	RTOR	App. Total	Left	Thru	RTOR	App. Total			
12:00 PM	8	33	17	41	90	12	4	102	14	56	0	70	21	213	234
12:15 PM	13	31	7	44	104	13	0	117	16	55	0	71	7	232	239
12:30 PM	13	26	20	39	102	16	0	118	13	47	0	60	20	217	237
12:45 PM	13	22	3	35	96	18	1	114	8	53	0	61	4	210	214
Total	47	112	47	159	392	59	5	451	51	211	0	262	52	872	924
01:00 PM	8	32	9	40	96	13	0	109	11	41	0	52	9	201	210
01:15 PM	10	35	10	45	83	14	0	97	13	51	0	64	10	206	216
01:30 PM	9	44	22	53	106	14	0	120	15	42	0	57	22	230	252
01:45 PM	11	28	10	39	101	13	1	114	14	54	0	68	11	221	232
Total	38	139	51	177	386	54	1	440	53	188	0	241	52	858	910
Grand Total	85	251	98	336	778	113	6	891	104	399	0	503	104	1730	1834
Apprch %	25.3	74.7			87.3	12.7			20.7	79.3					
Total %	4.9	14.5		19.4	45	6.5		51.5	6	23.1		29.1	5.7	94.3	

Start Time	North Shore Drive Southbound			SR-18 Westbound			SR-18 Eastbound			Int. Total
	Left	Right	App. Total	Thru	Right	App. Total	Left	Thru	App. Total	
12:00 PM	8	33	41	90	12	102	14	56	70	213
12:15 PM	13	31	44	104	13	117	16	55	71	232
12:30 PM	13	26	39	102	16	118	13	47	60	217
12:45 PM	13	22	35	96	18	114	8	53	61	210
Total Volume	47	112	159	392	59	451	51	211	262	872
% App. Total	29.6	70.4		86.9	13.1		19.5	80.5		
PHF	.904	.848	.903	.942	.819	.956	.797	.942	.923	.940

Peak Hour Analysis From 12:00 PM to 12:45 PM - Peak 1 of 1
 Peak Hour for Entire Intersection Begins at 12:00 PM

County of San Bernardino
 N/S: North Shore Drive (SR-38)
 E/W: SR-18 (Big Bear Boulevard)
 Weather: Clear

File Name : CSBSH18SUN
 Site Code : 05116469
 Start Date : 9/11/2016
 Page No : 2

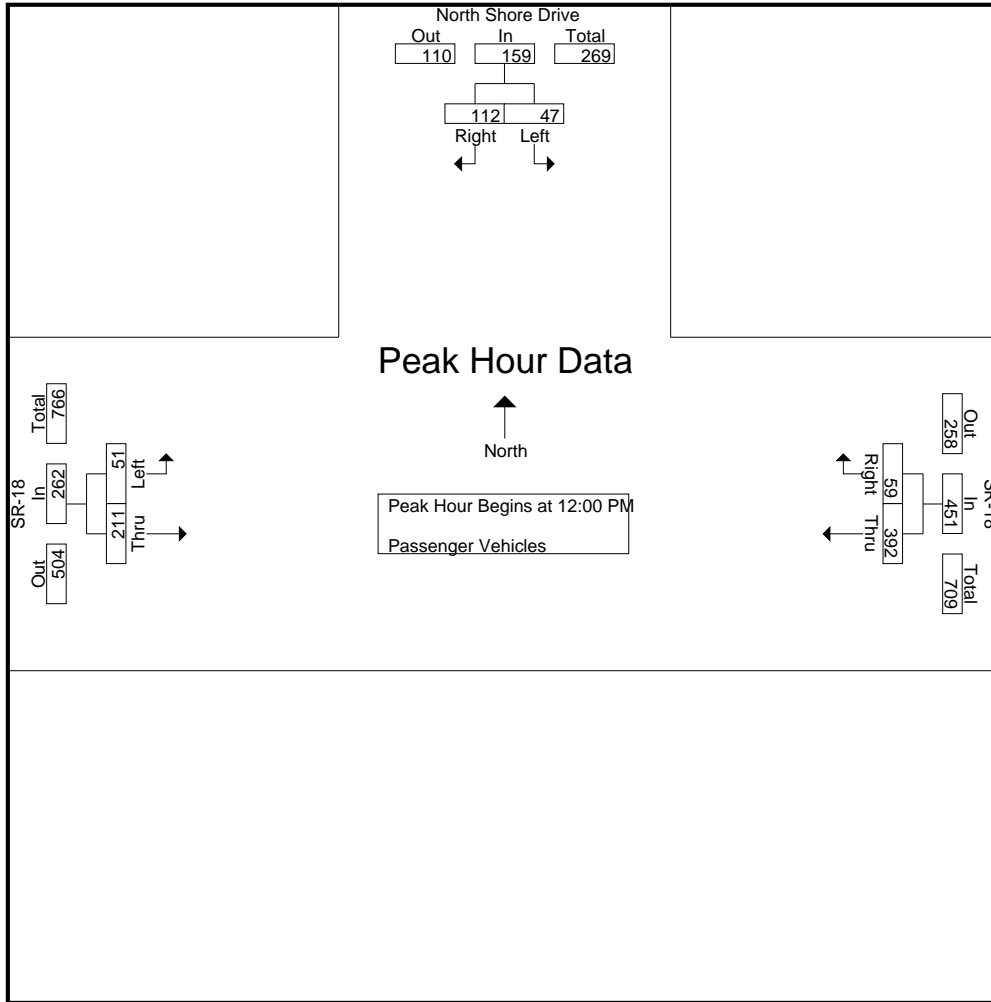

Peak Hour Analysis From 12:00 PM to 12:45 PM - Peak 1 of 1
 Peak Hour for Each Approach Begins at:

	12:00 PM			12:00 PM			12:00 PM		
+0 mins.	8	33	41	90	12	102	14	56	70
+15 mins.	13	31	44	104	13	117	16	55	71
+30 mins.	13	26	39	102	16	118	13	47	60
+45 mins.	13	22	35	96	18	114	8	53	61
Total Volume	47	112	159	392	59	451	51	211	262
% App. Total	29.6	70.4		86.9	13.1		19.5	80.5	
PHF	.904	.848	.903	.942	.819	.956	.797	.942	.923

County of San Bernardino
 N/S: North Shore Drive (SR-38)
 E/W: SR-18 (Big Bear Boulevard)
 Weather: Clear

File Name : CSBSH18SUN
 Site Code : 05116469
 Start Date : 9/11/2016
 Page No : 1

Groups Printed- Large 2 Axle Vehicles

Start Time	North Shore Drive Southbound				SR-18 Westbound				SR-18 Eastbound				Exclu. Total	Inclu. Total	Int. Total
	Left	Right	RTOR	App. Total	Thru	Right	RTOR	App. Total	Left	Thru	RTOR	App. Total			
12:00 PM	0	0	0	0	0	0	0	0	0	0	0	0	0	0	0
12:15 PM	0	0	0	0	1	0	0	1	0	0	0	0	0	1	1
12:30 PM	0	0	0	0	0	0	0	0	0	0	0	0	0	0	0
12:45 PM	0	0	0	0	2	0	0	2	1	0	0	1	0	3	3
Total	0	0	0	0	3	0	0	3	1	0	0	1	0	4	4
01:00 PM	0	0	0	0	1	0	0	1	1	0	0	1	0	2	2
01:15 PM	0	0	0	0	0	0	0	0	0	0	0	0	0	0	0
01:30 PM	0	0	0	0	1	0	0	1	1	0	0	1	0	2	2
01:45 PM	1	0	0	1	0	0	0	0	0	0	0	0	0	1	1
Total	1	0	0	1	2	0	0	2	2	0	0	2	0	5	5
Grand Total	1	0	0	1	5	0	0	5	3	0	0	3	0	9	9
Apprch %	100	0			100	0			100	0					
Total %	11.1	0		11.1	55.6	0		55.6	33.3	0		33.3	0	100	

Start Time	North Shore Drive Southbound			SR-18 Westbound			SR-18 Eastbound			Int. Total
	Left	Right	App. Total	Thru	Right	App. Total	Left	Thru	App. Total	
12:00 PM	0	0	0	0	0	0	0	0	0	0
12:15 PM	0	0	0	1	0	1	0	0	0	1
12:30 PM	0	0	0	0	0	0	0	0	0	0
12:45 PM	0	0	0	2	0	2	1	0	1	3
Total Volume	0	0	0	3	0	3	1	0	1	4
% App. Total	0	0		100	0		100	0		
PHF	.000	.000	.000	.375	.000	.375	.250	.000	.250	.333

Peak Hour Analysis From 12:00 PM to 12:45 PM - Peak 1 of 1
 Peak Hour for Entire Intersection Begins at 12:00 PM

County of San Bernardino
 N/S: North Shore Drive (SR-38)
 E/W: SR-18 (Big Bear Boulevard)
 Weather: Clear

File Name : CSBSH18SUN
 Site Code : 05116469
 Start Date : 9/11/2016
 Page No : 2

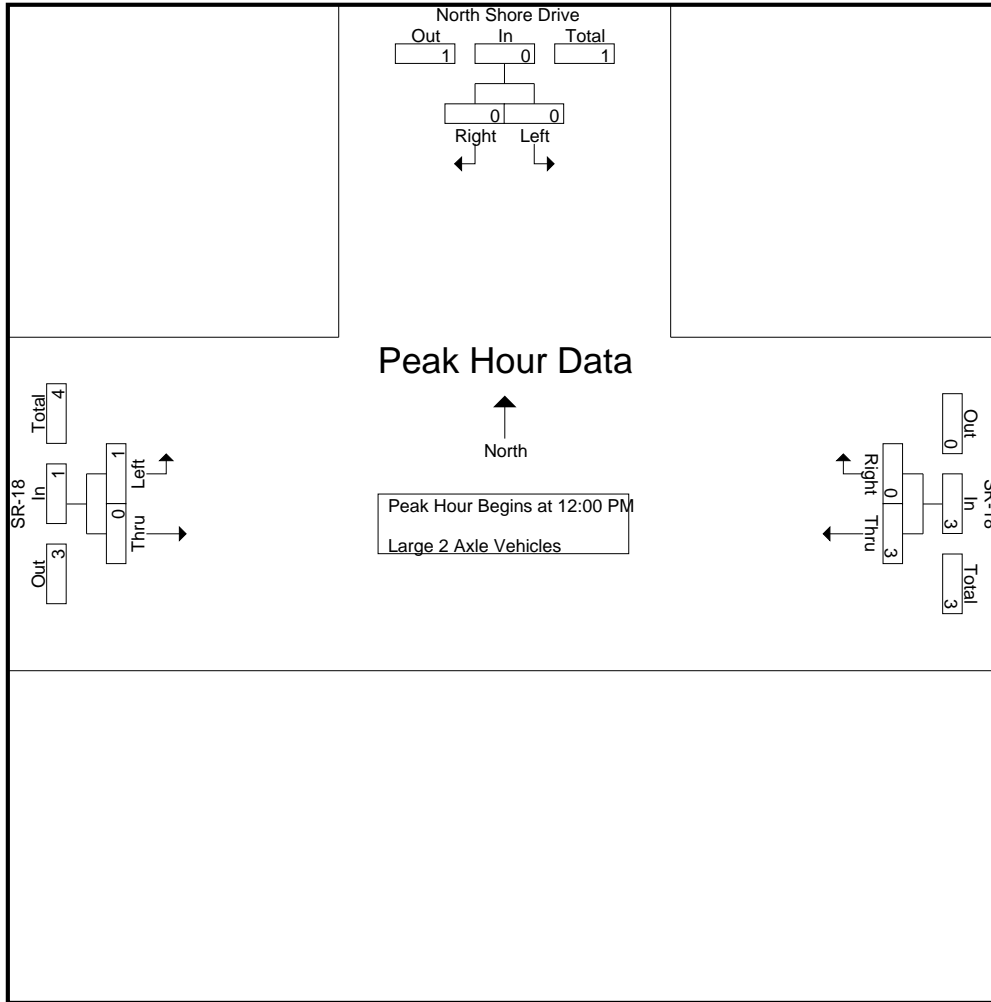

Peak Hour Analysis From 12:00 PM to 12:45 PM - Peak 1 of 1
 Peak Hour for Each Approach Begins at:

	12:00 PM			12:00 PM			12:00 PM		
+0 mins.	0	0	0	0	0	0	0	0	0
+15 mins.	0	0	0	1	0	1	0	0	0
+30 mins.	0	0	0	0	0	0	0	0	0
+45 mins.	0	0	0	2	0	2	1	0	1
Total Volume	0	0	0	3	0	3	1	0	1
% App. Total	0	0	0	100	0	100	100	0	100
PHF	.000	.000	.000	.375	.000	.375	.250	.000	.250

County of San Bernardino
 N/S: North Shore Drive (SR-38)
 E/W: SR-18 (Big Bear Boulevard)
 Weather: Clear

File Name : CSBSH18SUN
 Site Code : 05116469
 Start Date : 9/11/2016
 Page No : 1

Groups Printed- 3 Axle Vehicles

Start Time	North Shore Drive Southbound				SR-18 Westbound				SR-18 Eastbound				Exclu. Total	Inclu. Total	Int. Total
	Left	Right	RTOR	App. Total	Thru	Right	RTOR	App. Total	Left	Thru	RTOR	App. Total			
12:00 PM	0	0	0	0	0	0	0	0	0	0	0	0	0	0	0
12:15 PM	0	0	0	0	0	0	0	0	0	0	0	0	0	0	0
12:30 PM	0	0	0	0	0	0	0	0	0	1	0	1	0	1	1
12:45 PM	0	0	0	0	0	0	0	0	0	0	0	0	0	0	0
Total	0	0	0	0	0	0	0	0	0	1	0	1	0	1	1
01:00 PM	0	0	0	0	0	0	0	0	0	0	0	0	0	0	0
01:15 PM	0	0	0	0	0	0	0	0	0	0	0	0	0	0	0
01:30 PM	0	0	0	0	0	0	0	0	0	0	0	0	0	0	0
01:45 PM	0	0	0	0	0	0	0	0	0	0	0	0	0	0	0
Total	0	0	0	0	0	0	0	0	0	0	0	0	0	0	0
Grand Total	0	0	0	0	0	0	0	0	0	1	0	1	0	1	1
Apprch %	0	0			0	0			0	100					
Total %	0	0		0	0	0		0	0	100		100	0	100	

Start Time	North Shore Drive Southbound			SR-18 Westbound			SR-18 Eastbound			Int. Total
	Left	Right	App. Total	Thru	Right	App. Total	Left	Thru	App. Total	
12:00 PM	0	0	0	0	0	0	0	0	0	0
12:15 PM	0	0	0	0	0	0	0	0	0	0
12:30 PM	0	0	0	0	0	0	0	1	1	1
12:45 PM	0	0	0	0	0	0	0	0	0	0
Total Volume	0	0	0	0	0	0	0	1	1	1
% App. Total	0	0		0	0		0	100		
PHF	.000	.000	.000	.000	.000	.000	.000	.250	.250	.250

Peak Hour Analysis From 12:00 PM to 12:45 PM - Peak 1 of 1
 Peak Hour for Entire Intersection Begins at 12:00 PM

County of San Bernardino
 N/S: North Shore Drive (SR-38)
 E/W: SR-18 (Big Bear Boulevard)
 Weather: Clear

File Name : CSBSH18SUN
 Site Code : 05116469
 Start Date : 9/11/2016
 Page No : 2

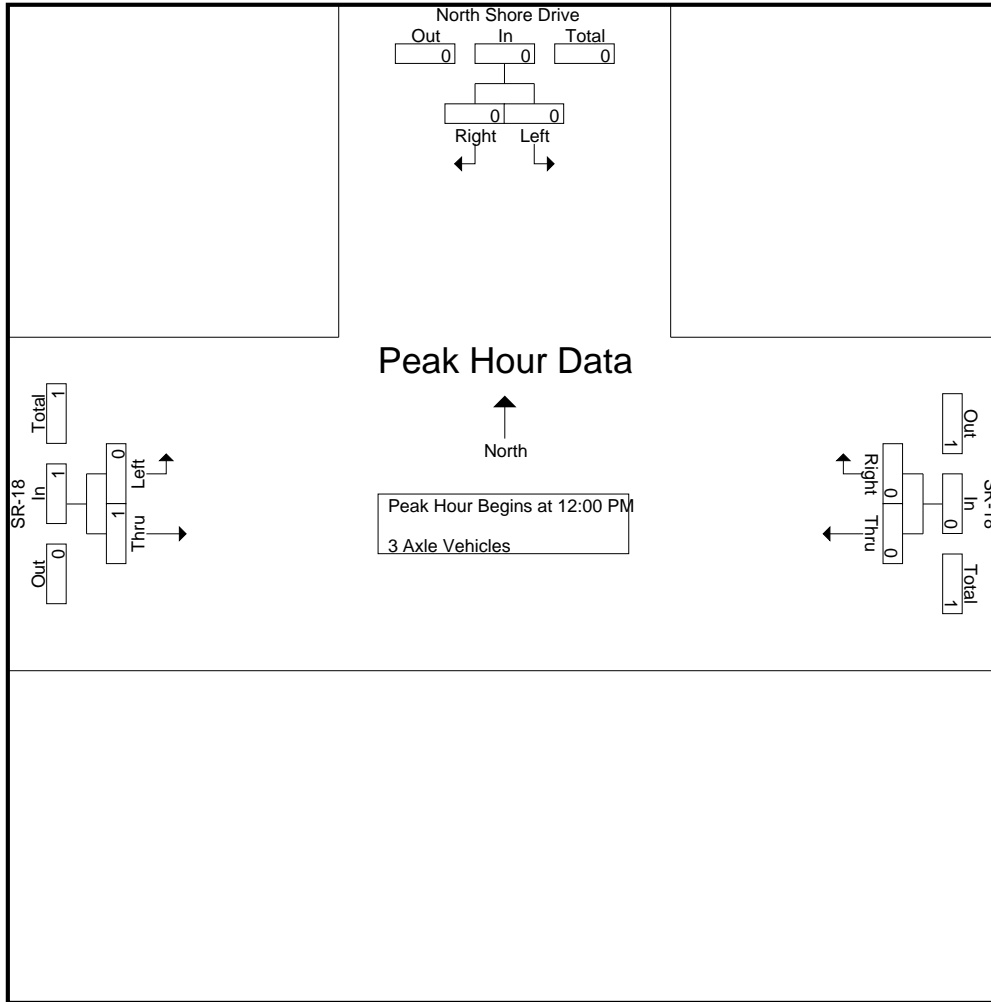

Peak Hour Analysis From 12:00 PM to 12:45 PM - Peak 1 of 1
 Peak Hour for Each Approach Begins at:

	12:00 PM			12:00 PM			12:00 PM		
+0 mins.	0	0	0	0	0	0	0	0	0
+15 mins.	0	0	0	0	0	0	0	0	0
+30 mins.	0	0	0	0	0	0	0	1	1
+45 mins.	0	0	0	0	0	0	0	0	0
Total Volume	0	0	0	0	0	0	0	1	1
% App. Total	0	0	0	0	0	0	0	100	100
PHF	.000	.000	.000	.000	.000	.000	.000	.250	.250

County of San Bernardino
 N/S: North Shore Drive (SR-38)
 E/W: SR-18 (Big Bear Boulevard)
 Weather: Clear

File Name : CSBSH18SUN
 Site Code : 05116469
 Start Date : 9/11/2016
 Page No : 1

Groups Printed- 4+ Axle Trucks

Start Time	North Shore Drive Southbound				SR-18 Westbound				SR-18 Eastbound				Exclu. Total	Inclu. Total	Int. Total
	Left	Right	RTOR	App. Total	Thru	Right	RTOR	App. Total	Left	Thru	RTOR	App. Total			
12:00 PM	0	0	0	0	0	0	0	0	0	0	0	0	0	0	0
12:15 PM	0	0	0	0	0	0	0	0	0	0	0	0	0	0	0
12:30 PM	0	0	0	0	0	0	0	0	0	0	0	0	0	0	0
12:45 PM	0	0	0	0	0	0	0	0	0	0	0	0	0	0	0
Total	0	0	0	0	0	0	0	0	0	0	0	0	0	0	0
01:00 PM	0	0	0	0	0	0	0	0	0	0	0	0	0	0	0
01:15 PM	0	0	0	0	0	0	0	0	0	0	0	0	0	0	0
01:30 PM	0	0	0	0	1	0	0	1	0	0	0	0	0	1	1
01:45 PM	0	0	0	0	0	0	0	0	0	0	0	0	0	0	0
Total	0	0	0	0	1	0	0	1	0	0	0	0	0	1	1
Grand Total	0	0	0	0	1	0	0	1	0	0	0	0	0	1	1
Apprch %	0	0			100	0			0	0					
Total %	0	0		0	100	0		100	0	0		0	0	100	

Start Time	North Shore Drive Southbound			SR-18 Westbound			SR-18 Eastbound			Int. Total
	Left	Right	App. Total	Thru	Right	App. Total	Left	Thru	App. Total	
12:00 PM	0	0	0	0	0	0	0	0	0	0
12:15 PM	0	0	0	0	0	0	0	0	0	0
12:30 PM	0	0	0	0	0	0	0	0	0	0
12:45 PM	0	0	0	0	0	0	0	0	0	0
Total Volume	0	0	0	0	0	0	0	0	0	0
% App. Total	0	0		0	0		0	0		
PHF	.000	.000	.000	.000	.000	.000	.000	.000	.000	.000

Peak Hour Analysis From 12:00 PM to 12:45 PM - Peak 1 of 1
 Peak Hour for Entire Intersection Begins at 12:00 PM

Location: County of San Bernardino
 N/S: North Shore Drive (SR-38)
 E/W: SR-18 (Big Bear Boulevard)



PEDESTRIANS

Date: 9/9/2016

Day: Friday

	North Leg North Shore Drive (SR-38)	East Leg SR-18 (Big Bear Boulevard)	South Leg North Shore Drive (SR-38)	West Leg SR-18 (Big Bear Boulevard)	TOTAL
4:00 PM	0	0	0	1	1
4:15 PM	0	0	0	0	0
4:30 PM	1	0	0	0	1
4:45 PM	1	0	0	0	1
5:00 PM	0	0	0	0	0
5:15 PM	0	0	0	0	0
5:30 PM	0	0	0	0	0
5:45 PM	0	0	0	0	0
TOTAL VOLUMES:	2	0	0	1	3

Date: 9/11/2016

Day: Sunday

	North Leg North Shore Drive (SR-38)	East Leg SR-18 (Big Bear Boulevard)	South Leg North Shore Drive (SR-38)	West Leg SR-18 (Big Bear Boulevard)	TOTAL
12:00 PM	0	0	0	0	0
12:15 PM	0	0	0	0	0
12:30 PM	0	0	0	0	0
12:45 PM	0	0	0	0	0
1:00 PM	0	0	0	0	0
1:15 PM	0	0	0	0	0
1:30 PM	2	0	0	0	2
1:45 PM	0	0	0	0	0
TOTAL VOLUMES:	2	0	0	0	2

Location: County of San Bernardino
 N/S: North Shore Drive (SR-38)
 E/W: SR-18 (Big Bear Boulevard)



BICYCLES

Date: 9/9/2016
 Day: Friday

	North Leg North Shore Drive (SR-38)	East Leg SR-18 (Big Bear Boulevard)	South Leg North Shore Drive (SR-38)	West Leg SR-18 (Big Bear Boulevard)	TOTAL
4:00 PM	0	0	0	0	0
4:15 PM	0	0	0	0	0
4:30 PM	0	0	0	0	0
4:45 PM	0	0	0	0	0
5:00 PM	0	0	0	0	0
5:15 PM	0	0	0	0	0
5:30 PM	0	0	0	0	0
5:45 PM	0	0	0	0	0
TOTAL VOLUMES:	0	0	0	0	0

Date: 9/11/2016
 Day: Sunday

	North Leg North Shore Drive (SR-38)	East Leg SR-18 (Big Bear Boulevard)	South Leg North Shore Drive (SR-38)	West Leg SR-18 (Big Bear Boulevard)	TOTAL
12:00 PM	0	0	0	0	0
12:15 PM	0	0	0	0	0
12:30 PM	0	0	0	0	0
12:45 PM	0	0	0	0	0
1:00 PM	0	0	0	0	0
1:15 PM	0	0	0	0	0
1:30 PM	0	0	0	0	0
1:45 PM	0	0	0	0	0
TOTAL VOLUMES:	0	0	0	0	0

County of San Bernardino
 N/S: Stanfield Cutoff
 E/W: North Shore Drive (SR-38)
 Weather: Clear

File Name : CSBSTSHPM
 Site Code : 05116469
 Start Date : 9/9/2016
 Page No : 1

Groups Printed- Passenger Vehicles - Large 2 Axle Vehicles - 3 Axle Vehicles - 4+ Axle Trucks

Start Time	VCA Lakeside Animal Hospital DW Southbound					North Shore Drive Westbound					Stanfield Cutoff Northbound					North Shore Drive Eastbound					Exclu. Total	Inclu. Total	Int. Total
	Left	Thru	Right	RTOR	App. Total	Left	Thru	Right	RTOR	App. Total	Left	Thru	Right	RTOR	App. Total	Left	Thru	Right	RTOR	App. Total			
04:00 PM	0	3	0	0	3	46	15	3	0	64	20	0	34	1	54	0	11	24	0	35	1	156	157
04:15 PM	1	1	0	0	2	46	19	0	1	65	19	1	47	1	67	0	14	25	0	39	2	173	175
04:30 PM	2	2	0	0	4	38	21	1	0	60	19	3	35	0	57	0	11	33	0	44	0	165	165
04:45 PM	1	2	0	0	3	47	15	0	0	62	22	2	45	0	69	0	19	23	0	42	0	176	176
Total	4	8	0	0	12	177	70	4	1	251	80	6	161	2	247	0	55	105	0	160	3	670	673
05:00 PM	1	1	0	0	2	46	18	0	0	64	20	1	38	1	59	0	26	21	0	47	1	172	173
05:15 PM	0	2	1	0	3	42	7	1	0	50	31	2	41	0	74	0	18	19	0	37	0	164	164
05:30 PM	1	1	0	0	2	35	10	2	0	47	11	1	22	0	34	0	10	28	0	38	0	121	121
05:45 PM	2	0	0	0	2	41	11	0	1	52	20	1	42	0	63	0	15	19	0	34	1	151	152
Total	4	4	1	0	9	164	46	3	1	213	82	5	143	1	230	0	69	87	0	156	2	608	610
Grand Total	8	12	1	0	21	341	116	7	2	464	162	11	304	3	477	0	124	192	0	316	5	1278	1283
Apprch %	38.1	57.1	4.8			73.5	25	1.5			34	2.3	63.7			0	39.2	60.8					
Total %	0.6	0.9	0.1		1.6	26.7	9.1	0.5		36.3	12.7	0.9	23.8		37.3	0	9.7	15		24.7	0.4	99.6	
Passenger Vehicles	8	12	1		21	334	115	7		456	160	11	300		471	0	122	191		313	0	0	1261
% Passenger Vehicles	100	100	100		100	97.9	99.1	100		97.9	98.8	100	98.7		98.1	0	98.4	99.5		99.1	0	0	98.3
Large 2 Axle Vehicles	0	0	0		0	5	1	0		8	2	0	0		2	0	2	1		3	0	0	13
% Large 2 Axle Vehicles	0	0	0		0	1.5	0.9	0		1.7	1.2	0	0		0.4	0	1.6	0.5		0.9	0	0	1
3 Axle Vehicles	0	0	0		0	2	0	0		2	0	0	3		3	0	0	0		0	0	0	5
% 3 Axle Vehicles	0	0	0		0	0.6	0	0		0.4	0	0	1		0.6	0	0	0		0	0	0	0.4
4+ Axle Trucks	0	0	0		0	0	0	0		0	0	0	1		4	0	0	0		0	0	0	4
% 4+ Axle Trucks	0	0	0		0	0	0	0		0	0	0	0.3		0.8	0	0	0		0	0	0	0.3

Start Time	VCA Lakeside Animal Hospital DW Southbound				North Shore Drive Westbound				Stanfield Cutoff Northbound				North Shore Drive Eastbound				Int. Total
	Left	Thru	Right	App. Total	Left	Thru	Right	App. Total	Left	Thru	Right	App. Total	Left	Thru	Right	App. Total	
Peak Hour Analysis From 04:00 PM to 05:45 PM - Peak 1 of 1																	
Peak Hour for Entire Intersection Begins at 04:15 PM																	
04:15 PM	1	1	0	2	46	19	0	65	19	1	47	67	0	14	25	39	173
04:30 PM	2	2	0	4	38	21	1	60	19	3	35	57	0	11	33	44	165
04:45 PM	1	2	0	3	47	15	0	62	22	2	45	69	0	19	23	42	176
05:00 PM	1	1	0	2	46	18	0	64	20	1	38	59	0	26	21	47	172
Total Volume	5	6	0	11	177	73	1	251	80	7	165	252	0	70	102	172	686
% App. Total	45.5	54.5	0		70.5	29.1	0.4		31.7	2.8	65.5		0	40.7	59.3		
PHF	.625	.750	.000	.688	.941	.869	.250	.965	.909	.583	.878	.913	.000	.673	.773	.915	.974

Counts Unlimited
 PO Box 1178
 Corona, CA 92878
 (951) 268-6268

County of San Bernardino
 N/S: Stanfield Cutoff
 E/W: North Shore Drive (SR-38)
 Weather: Clear

File Name : CSBSTSHPM
 Site Code : 05116469
 Start Date : 9/9/2016
 Page No : 2

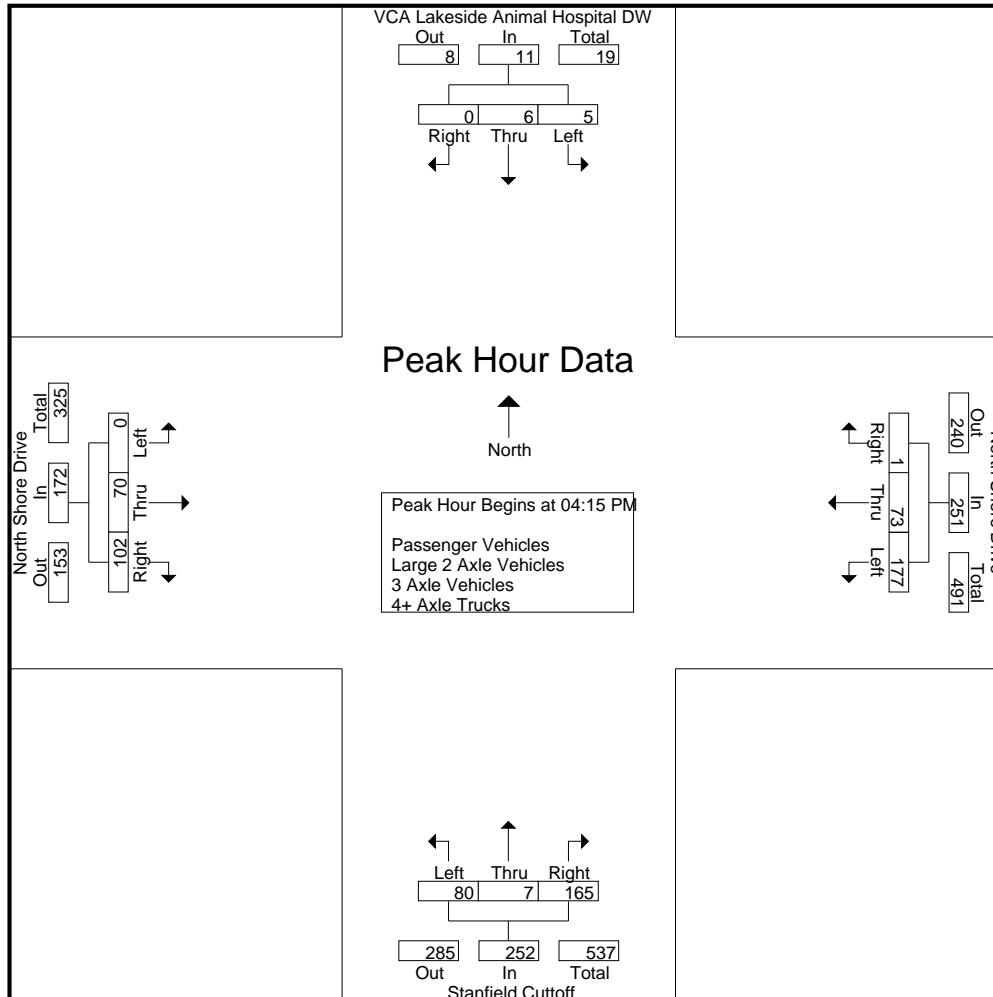

Counts Unlimited
 PO Box 1178
 Corona, CA 92878
 (951) 268-6268

County of San Bernardino
 N/S: Stanfield Cutoff
 E/W: North Shore Drive (SR-38)
 Weather: Clear

File Name : CSBSTSHPM
 Site Code : 05116469
 Start Date : 9/9/2016
 Page No : 3

Start Time	VCA Lakeside Animal Hospital DW Southbound				North Shore Drive Westbound				Stanfield Cutoff Northbound				North Shore Drive Eastbound				Int. Total
	Left	Thru	Right	App. Total	Left	Thru	Right	App. Total	Left	Thru	Right	App. Total	Left	Thru	Right	App. Total	

Peak Hour Analysis From 04:00 PM to 05:45 PM - Peak 1 of 1

Peak Hour for Each Approach Begins at:

	04:00 PM				04:00 PM				04:30 PM				04:15 PM			
+0 mins.	0	3	0	3	46	15	3	64	19	3	35	57	0	14	25	39
+15 mins.	1	1	0	2	46	19	0	65	22	2	45	69	0	11	33	44
+30 mins.	2	2	0	4	38	21	1	60	20	1	38	59	0	19	23	42
+45 mins.	1	2	0	3	47	15	0	62	31	2	41	74	0	26	21	47
Total Volume	4	8	0	12	177	70	4	251	92	8	159	259	0	70	102	172
% App. Total	33.3	66.7	0		70.5	27.9	1.6		35.5	3.1	61.4		0	40.7	59.3	
PHF	.500	.667	.000	.750	.941	.833	.333	.965	.742	.667	.883	.875	.000	.673	.773	.915

Counts Unlimited
 PO Box 1178
 Corona, CA 92878
 (951) 268-6268

County of San Bernardino
 N/S: Stanfield Cutoff
 E/W: North Shore Drive (SR-38)
 Weather: Clear

File Name : CSBSTSHPM
 Site Code : 05116469
 Start Date : 9/9/2016
 Page No : 1

Groups Printed- Passenger Vehicles

Start Time	VCA Lakeside Animal Hospital DW Southbound					North Shore Drive Westbound					Stanfield Cutoff Northbound					North Shore Drive Eastbound					Exclu. Total	Inclu. Total	Int. Total
	Left	Thru	Right	RTOR	App. Total	Left	Thru	Right	RTOR	App. Total	Left	Thru	Right	RTOR	App. Total	Left	Thru	Right	RTOR	App. Total			
04:00 PM	0	3	0	0	3	46	14	3	0	63	20	0	33	0	53	0	11	24	0	35	0	154	154
04:15 PM	1	1	0	0	2	43	19	0	0	62	19	1	46	0	66	0	14	24	0	38	0	168	168
04:30 PM	2	2	0	0	4	38	21	1	0	60	19	3	35	0	57	0	10	33	0	43	0	164	164
04:45 PM	1	2	0	0	3	47	15	0	0	62	22	2	45	0	69	0	19	23	0	42	0	176	176
Total	4	8	0	0	12	174	69	4	0	247	80	6	159	0	245	0	54	104	0	158	0	662	662
05:00 PM	1	1	0	0	2	45	18	0	0	63	20	1	36	0	57	0	26	21	0	47	0	169	169
05:15 PM	0	2	1	0	3	42	7	1	0	50	29	2	41	0	72	0	17	19	0	36	0	161	161
05:30 PM	1	1	0	0	2	33	10	2	0	45	11	1	22	0	34	0	10	28	0	38	0	119	119
05:45 PM	2	0	0	0	2	40	11	0	0	51	20	1	42	0	63	0	15	19	0	34	0	150	150
Total	4	4	1	0	9	160	46	3	0	209	80	5	141	0	226	0	68	87	0	155	0	599	599
Grand Total	8	12	1	0	21	334	115	7	0	456	160	11	300	0	471	0	122	191	0	313	0	1261	1261
Apprch %	38.1	57.1	4.8			73.2	25.2	1.5			34	2.3	63.7			0	39	61					
Total %	0.6	1	0.1		1.7	26.5	9.1	0.6		36.2	12.7	0.9	23.8		37.4	0	9.7	15.1		24.8	0	100	

Start Time	VCA Lakeside Animal Hospital DW Southbound				North Shore Drive Westbound				Stanfield Cutoff Northbound				North Shore Drive Eastbound				Int. Total
	Left	Thru	Right	App. Total	Left	Thru	Right	App. Total	Left	Thru	Right	App. Total	Left	Thru	Right	App. Total	
Peak Hour Analysis From 04:15 PM to 05:00 PM - Peak 1 of 1																	
Peak Hour for Entire Intersection Begins at 04:15 PM																	
04:15 PM	1	1	0	2	43	19	0	62	19	1	46	66	0	14	24	38	168
04:30 PM	2	2	0	4	38	21	1	60	19	3	35	57	0	10	33	43	164
04:45 PM	1	2	0	3	47	15	0	62	22	2	45	69	0	19	23	42	176
05:00 PM	1	1	0	2	45	18	0	63	20	1	36	57	0	26	21	47	169
Total Volume	5	6	0	11	173	73	1	247	80	7	162	249	0	69	101	170	677
% App. Total	45.5	54.5	0		70	29.6	0.4		32.1	2.8	65.1		0	40.6	59.4		
PHF	.625	.750	.000	.688	.920	.869	.250	.980	.909	.583	.880	.902	.000	.663	.765	.904	.962

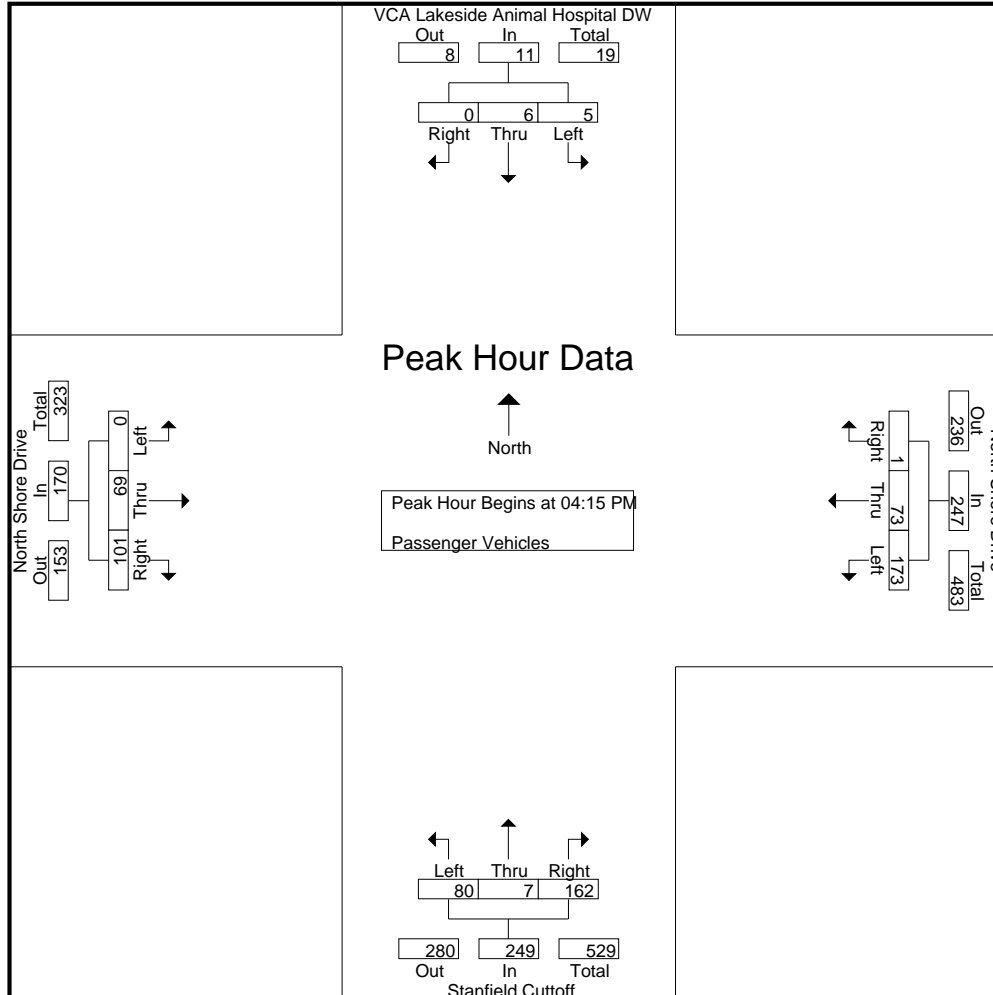

Counts Unlimited
 PO Box 1178
 Corona, CA 92878
 (951) 268-6268

County of San Bernardino
 N/S: Stanfield Cutoff
 E/W: North Shore Drive (SR-38)
 Weather: Clear

File Name : CSBSTSHPM
 Site Code : 05116469
 Start Date : 9/9/2016
 Page No : 3

Start Time	VCA Lakeside Animal Hospital DW Southbound				North Shore Drive Westbound				Stanfield Cutoff Northbound				North Shore Drive Eastbound				Int. Total
	Left	Thru	Right	App. Total	Left	Thru	Right	App. Total	Left	Thru	Right	App. Total	Left	Thru	Right	App. Total	
Peak Hour Analysis From 04:15 PM to 05:00 PM - Peak 1 of 1																	
Peak Hour for Each Approach Begins at:																	
	04:15 PM				04:15 PM				04:15 PM				04:15 PM				
+0 mins.	1	1	0	2	43	19	0	62	19	1	46	66	0	14	24	38	
+15 mins.	2	2	0	4	38	21	1	60	19	3	35	57	0	10	33	43	
+30 mins.	1	2	0	3	47	15	0	62	22	2	45	69	0	19	23	42	
+45 mins.	1	1	0	2	45	18	0	63	20	1	36	57	0	26	21	47	
Total Volume	5	6	0	11	173	73	1	247	80	7	162	249	0	69	101	170	
% App. Total	45.5	54.5	0		70	29.6	0.4		32.1	2.8	65.1		0	40.6	59.4		
PHF	.625	.750	.000	.688	.920	.869	.250	.980	.909	.583	.880	.902	.000	.663	.765	.904	

Counts Unlimited
 PO Box 1178
 Corona, CA 92878
 (951) 268-6268

County of San Bernardino
 N/S: Stanfield Cutoff
 E/W: North Shore Drive (SR-38)
 Weather: Clear

File Name : CSBSTSHPM
 Site Code : 05116469
 Start Date : 9/9/2016
 Page No : 1

Groups Printed- Large 2 Axle Vehicles

Start Time	VCA Lakeside Animal Hospital DW Southbound					North Shore Drive Westbound					Stanfield Cutoff Northbound					North Shore Drive Eastbound					Exclu. Total	Inclu. Total	Int. Total					
	Left	Thru	Right	RTOR	App. Total	Left	Thru	Right	RTOR	App. Total	Left	Thru	Right	RTOR	App. Total	Left	Thru	Right	RTOR	App. Total								
04:00 PM	0	0	0	0	0	0	1	0	0	1	0	0	0	0	0	0	0	0	0	0	0	0	0	0	0	0	1	1
04:15 PM	0	0	0	0	0	2	0	0	1	2	0	0	0	0	0	0	0	1	0	1	1	3	4	1	3	4		
04:30 PM	0	0	0	0	0	0	0	0	0	0	0	0	0	0	0	0	1	0	0	1	0	1	1	0	1	1		
04:45 PM	0	0	0	0	0	0	0	0	0	0	0	0	0	0	0	0	0	0	0	0	0	0	0	0	0	0		
Total	0	0	0	0	0	2	1	0	1	3	0	0	0	0	0	0	1	1	0	2	1	5	6	1	5	6		
05:00 PM	0	0	0	0	0	1	0	0	0	1	0	0	0	0	0	0	0	0	0	0	0	1	1	0	1	1		
05:15 PM	0	0	0	0	0	0	0	0	0	0	2	0	0	0	2	0	1	0	0	1	0	3	3	0	3	3		
05:30 PM	0	0	0	0	0	2	0	0	0	2	0	0	0	0	0	0	0	0	0	0	0	2	2	0	2	2		
05:45 PM	0	0	0	0	0	0	0	0	1	0	0	0	0	0	0	0	0	0	0	0	1	0	1	1	0	1		
Total	0	0	0	0	0	3	0	0	1	3	2	0	0	0	2	0	1	0	0	1	1	6	7	1	6	7		
Grand Total	0	0	0	0	0	5	1	0	2	6	2	0	0	0	2	0	2	1	0	3	2	11	13	2	11	13		
Apprch %	0	0	0			83.3	16.7	0			100	0	0			0	66.7	33.3										
Total %	0	0	0			45.5	9.1	0		54.5	18.2	0	0		18.2	0	18.2	9.1		27.3	15.4	84.6		15.4	84.6			

Start Time	VCA Lakeside Animal Hospital DW Southbound				North Shore Drive Westbound				Stanfield Cutoff Northbound				North Shore Drive Eastbound				Int. Total
	Left	Thru	Right	App. Total	Left	Thru	Right	App. Total	Left	Thru	Right	App. Total	Left	Thru	Right	App. Total	
Peak Hour Analysis From 04:15 PM to 05:00 PM - Peak 1 of 1																	
Peak Hour for Entire Intersection Begins at 04:15 PM																	
04:15 PM	0	0	0	0	2	0	0	2	0	0	0	0	0	0	1	1	3
04:30 PM	0	0	0	0	0	0	0	0	0	0	0	0	0	1	0	1	1
04:45 PM	0	0	0	0	0	0	0	0	0	0	0	0	0	0	0	0	0
05:00 PM	0	0	0	0	1	0	0	1	0	0	0	0	0	0	0	0	1
Total Volume	0	0	0	0	3	0	0	3	0	0	0	0	0	1	1	2	5
% App. Total	0	0	0	0	100	0	0	100	0	0	0	0	0	50	50	100	100
PHF	.000	.000	.000	.000	.375	.000	.000	.375	.000	.000	.000	.000	.000	.250	.250	.500	.417

County of San Bernardino
 N/S: Stanfield Cutoff
 E/W: North Shore Drive (SR-38)
 Weather: Clear

File Name : CSBSTSHPM
 Site Code : 05116469
 Start Date : 9/9/2016
 Page No : 2

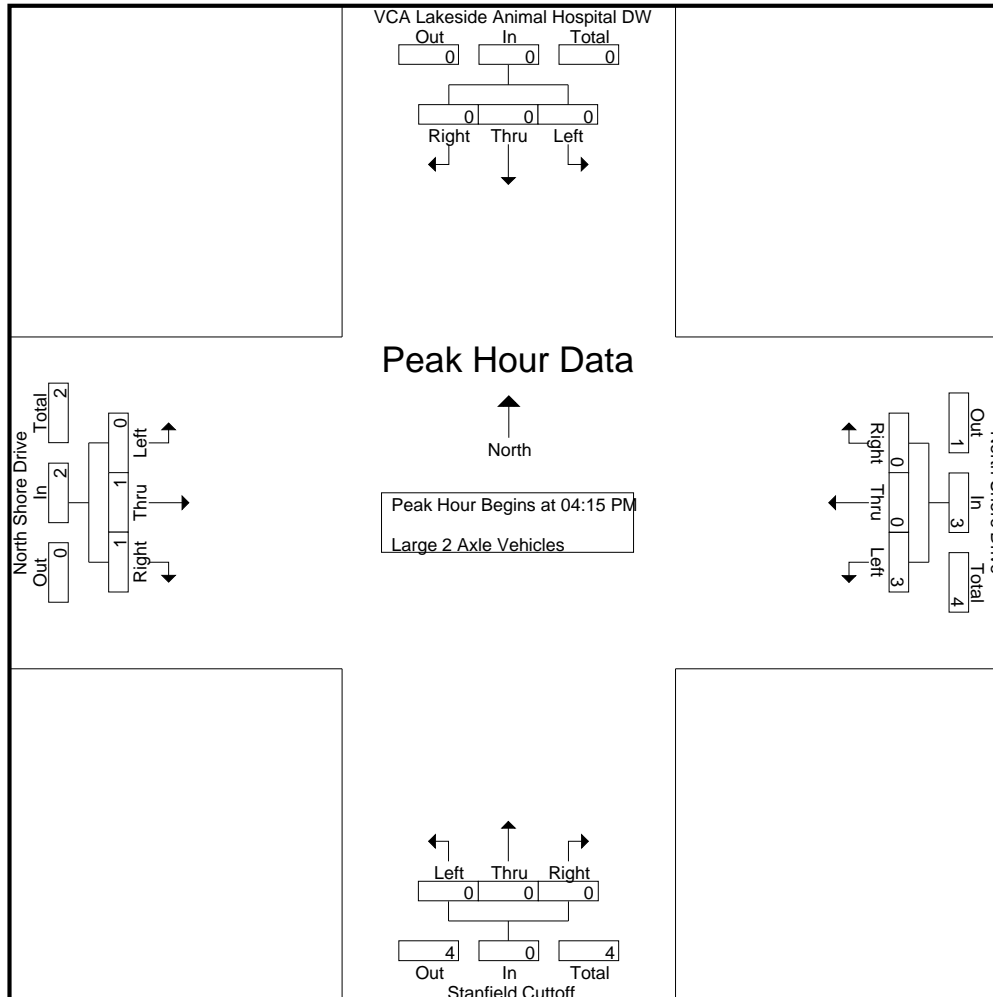

Counts Unlimited
 PO Box 1178
 Corona, CA 92878
 (951) 268-6268

County of San Bernardino
 N/S: Stanfield Cutoff
 E/W: North Shore Drive (SR-38)
 Weather: Clear

File Name : CSBSTSHPM
 Site Code : 05116469
 Start Date : 9/9/2016
 Page No : 3

Start Time	VCA Lakeside Animal Hospital DW Southbound				North Shore Drive Westbound				Stanfield Cutoff Northbound				North Shore Drive Eastbound				Int. Total
	Left	Thru	Right	App. Total	Left	Thru	Right	App. Total	Left	Thru	Right	App. Total	Left	Thru	Right	App. Total	
Peak Hour Analysis From 04:15 PM to 05:00 PM - Peak 1 of 1																	
Peak Hour for Each Approach Begins at:																	
	04:15 PM				04:15 PM				04:15 PM				04:15 PM				
+0 mins.	0	0	0	0	2	0	0	2	0	0	0	0	0	0	1	1	
+15 mins.	0	0	0	0	0	0	0	0	0	0	0	0	0	1	0	1	
+30 mins.	0	0	0	0	0	0	0	0	0	0	0	0	0	0	0	0	
+45 mins.	0	0	0	0	1	0	0	1	0	0	0	0	0	0	0	0	
Total Volume	0	0	0	0	3	0	0	3	0	0	0	0	0	1	1	2	
% App. Total	0	0	0	0	100	0	0	100	0	0	0	0	0	50	50	100	
PHF	.000	.000	.000	.000	.375	.000	.000	.375	.000	.000	.000	.000	.000	.250	.250	.500	

Counts Unlimited
 PO Box 1178
 Corona, CA 92878
 (951) 268-6268

County of San Bernardino
 N/S: Stanfield Cutoff
 E/W: North Shore Drive (SR-38)
 Weather: Clear

File Name : CSBSTSHPM
 Site Code : 05116469
 Start Date : 9/9/2016
 Page No : 1

Groups Printed- 3 Axle Vehicles

Start Time	VCA Lakeside Animal Hospital DW Southbound					North Shore Drive Westbound					Stanfield Cutoff Northbound					North Shore Drive Eastbound					Exclu. Total	Inclu. Total	Int. Total	
	Left	Thru	Right	RTOR	App. Total	Left	Thru	Right	RTOR	App. Total	Left	Thru	Right	RTOR	App. Total	Left	Thru	Right	RTOR	App. Total				
04:00 PM	0	0	0	0	0	0	0	0	0	0	0	0	1	0	1	0	0	0	0	0	0	0	1	1
04:15 PM	0	0	0	0	0	1	0	0	0	1	0	0	1	0	1	0	0	0	0	0	0	0	2	2
04:30 PM	0	0	0	0	0	0	0	0	0	0	0	0	0	0	0	0	0	0	0	0	0	0	0	0
04:45 PM	0	0	0	0	0	0	0	0	0	0	0	0	0	0	0	0	0	0	0	0	0	0	0	0
Total	0	0	0	0	0	1	0	0	0	1	0	0	2	0	2	0	0	0	0	0	0	0	3	3
05:00 PM	0	0	0	0	0	0	0	0	0	0	0	0	1	0	1	0	0	0	0	0	0	0	1	1
05:15 PM	0	0	0	0	0	0	0	0	0	0	0	0	0	0	0	0	0	0	0	0	0	0	0	0
05:30 PM	0	0	0	0	0	0	0	0	0	0	0	0	0	0	0	0	0	0	0	0	0	0	0	0
05:45 PM	0	0	0	0	0	1	0	0	0	1	0	0	0	0	0	0	0	0	0	0	0	0	1	1
Total	0	0	0	0	0	1	0	0	0	1	0	0	1	0	1	0	0	0	0	0	0	0	2	2
Grand Total	0	0	0	0	0	2	0	0	0	2	0	0	3	0	3	0	0	0	0	0	0	0	5	5
Apprch %	0	0	0			100	0	0			0	0	100			0	0	0						
Total %	0	0	0			40	0	0		40	0	0	60		60	0	0	0		0	0	100		

Start Time	VCA Lakeside Animal Hospital DW Southbound				North Shore Drive Westbound				Stanfield Cutoff Northbound				North Shore Drive Eastbound				Int. Total
	Left	Thru	Right	App. Total	Left	Thru	Right	App. Total	Left	Thru	Right	App. Total	Left	Thru	Right	App. Total	
Peak Hour Analysis From 04:15 PM to 05:00 PM - Peak 1 of 1																	
Peak Hour for Entire Intersection Begins at 04:15 PM																	
04:15 PM	0	0	0	0	1	0	0	1	0	0	1	1	0	0	0	0	2
04:30 PM	0	0	0	0	0	0	0	0	0	0	0	0	0	0	0	0	0
04:45 PM	0	0	0	0	0	0	0	0	0	0	0	0	0	0	0	0	0
05:00 PM	0	0	0	0	0	0	0	0	0	0	1	1	0	0	0	0	1
Total Volume	0	0	0	0	1	0	0	1	0	0	2	2	0	0	0	0	3
% App. Total	0	0	0	0	100	0	0		0	0	100		0	0	0		
PHF	.000	.000	.000	.000	.250	.000	.000	.250	.000	.000	.500	.500	.000	.000	.000	.000	.375

County of San Bernardino
 N/S: Stanfield Cutoff
 E/W: North Shore Drive (SR-38)
 Weather: Clear

File Name : CSBSTSHPM
 Site Code : 05116469
 Start Date : 9/9/2016
 Page No : 2

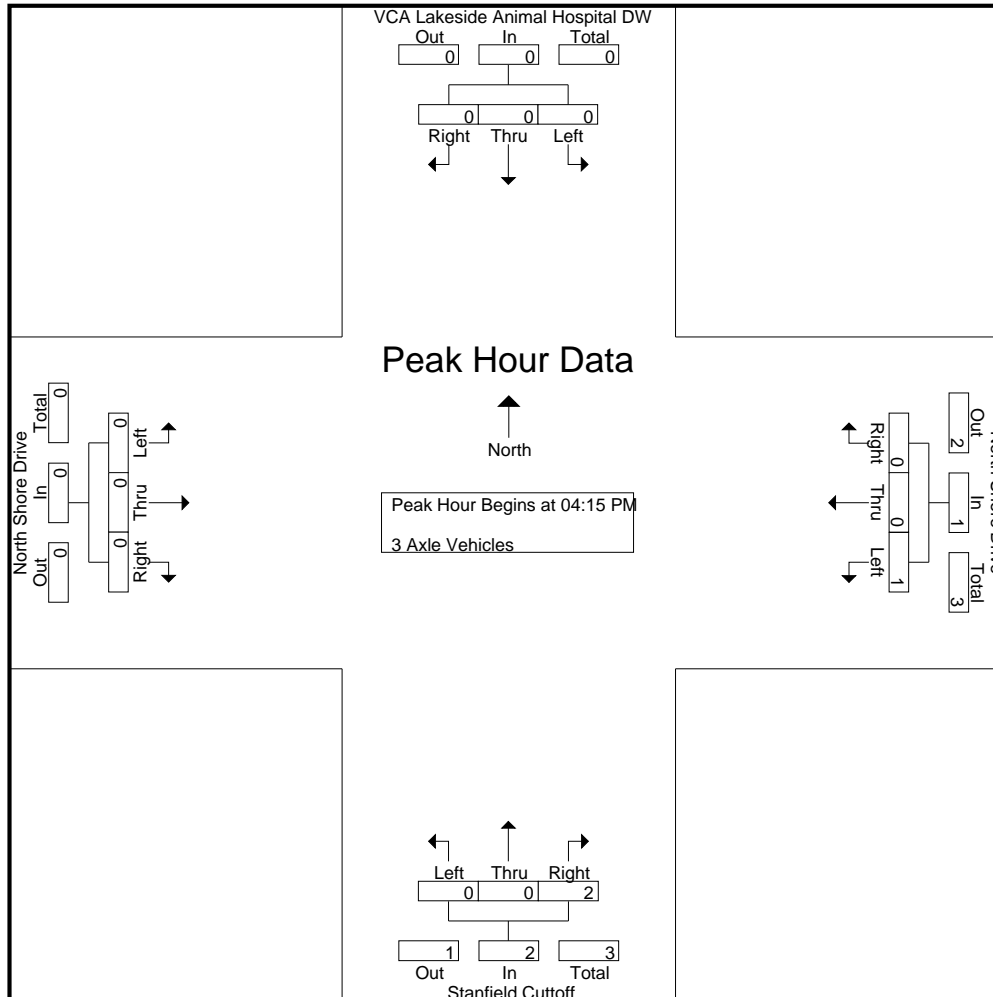

Counts Unlimited
 PO Box 1178
 Corona, CA 92878
 (951) 268-6268

County of San Bernardino
 N/S: Stanfield Cutoff
 E/W: North Shore Drive (SR-38)
 Weather: Clear

File Name : CSBSTSHPM
 Site Code : 05116469
 Start Date : 9/9/2016
 Page No : 3

Start Time	VCA Lakeside Animal Hospital DW Southbound				North Shore Drive Westbound				Stanfield Cutoff Northbound				North Shore Drive Eastbound				Int. Total
	Left	Thru	Right	App. Total	Left	Thru	Right	App. Total	Left	Thru	Right	App. Total	Left	Thru	Right	App. Total	
Peak Hour Analysis From 04:15 PM to 05:00 PM - Peak 1 of 1																	
Peak Hour for Each Approach Begins at:																	
	04:15 PM				04:15 PM				04:15 PM				04:15 PM				
+0 mins.	0	0	0	0	1	0	0	1	0	0	1	1	0	0	0	0	
+15 mins.	0	0	0	0	0	0	0	0	0	0	0	0	0	0	0	0	
+30 mins.	0	0	0	0	0	0	0	0	0	0	0	0	0	0	0	0	
+45 mins.	0	0	0	0	0	0	0	0	0	0	1	1	0	0	0	0	
Total Volume	0	0	0	0	1	0	0	1	0	0	2	2	0	0	0	0	
% App. Total	0	0	0	0	100	0	0	100	0	0	100	100	0	0	0	0	
PHF	.000	.000	.000	.000	.250	.000	.000	.250	.000	.000	.500	.500	.000	.000	.000	.000	

Counts Unlimited
 PO Box 1178
 Corona, CA 92878
 (951) 268-6268

County of San Bernardino
 N/S: Stanfield Cutoff
 E/W: North Shore Drive (SR-38)
 Weather: Clear

File Name : CSBSTSHPM
 Site Code : 05116469
 Start Date : 9/9/2016
 Page No : 1

Groups Printed- 4+ Axle Trucks

Start Time	VCA Lakeside Animal Hospital DW Southbound					North Shore Drive Westbound					Stanfield Cutoff Northbound					North Shore Drive Eastbound					Exclu. Total	Inclu. Total	Int. Total
	Left	Thru	Right	RTOR	App. Total	Left	Thru	Right	RTOR	App. Total	Left	Thru	Right	RTOR	App. Total	Left	Thru	Right	RTOR	App. Total			
04:00 PM	0	0	0	0	0	0	0	0	0	0	0	0	0	1	0	0	0	0	0	0	1	0	1
04:15 PM	0	0	0	0	0	0	0	0	0	0	0	0	0	1	0	0	0	0	0	0	1	0	1
04:30 PM	0	0	0	0	0	0	0	0	0	0	0	0	0	0	0	0	0	0	0	0	0	0	0
04:45 PM	0	0	0	0	0	0	0	0	0	0	0	0	0	0	0	0	0	0	0	0	0	0	0
Total	0	0	0	0	0	0	0	0	0	0	0	0	0	2	0	0	0	0	0	0	2	0	2
05:00 PM	0	0	0	0	0	0	0	0	0	0	0	0	1	1	1	0	0	0	0	0	1	1	2
05:15 PM	0	0	0	0	0	0	0	0	0	0	0	0	0	0	0	0	0	0	0	0	0	0	0
05:30 PM	0	0	0	0	0	0	0	0	0	0	0	0	0	0	0	0	0	0	0	0	0	0	0
05:45 PM	0	0	0	0	0	0	0	0	0	0	0	0	0	0	0	0	0	0	0	0	0	0	0
Total	0	0	0	0	0	0	0	0	0	0	0	0	1	1	1	0	0	0	0	0	1	1	2
Grand Total	0	0	0	0	0	0	0	0	0	0	0	0	1	3	1	0	0	0	0	0	3	1	4
Apprch %	0	0	0			0	0	0			0	0	100			0	0	0					
Total %	0	0	0		0	0	0	0		0	0	0	100		100	0	0	0		0	75	25	

Start Time	VCA Lakeside Animal Hospital DW Southbound				North Shore Drive Westbound				Stanfield Cutoff Northbound				North Shore Drive Eastbound				Int. Total
	Left	Thru	Right	App. Total	Left	Thru	Right	App. Total	Left	Thru	Right	App. Total	Left	Thru	Right	App. Total	
Peak Hour Analysis From 04:15 PM to 05:00 PM - Peak 1 of 1																	
Peak Hour for Entire Intersection Begins at 04:15 PM																	
04:15 PM	0	0	0	0	0	0	0	0	0	0	0	0	0	0	0	0	0
04:30 PM	0	0	0	0	0	0	0	0	0	0	0	0	0	0	0	0	0
04:45 PM	0	0	0	0	0	0	0	0	0	0	0	0	0	0	0	0	0
05:00 PM	0	0	0	0	0	0	0	0	0	0	1	1	0	0	0	0	1
Total Volume	0	0	0	0	0	0	0	0	0	0	1	1	0	0	0	0	1
% App. Total	0	0	0	0	0	0	0	0	0	0	100		0	0	0		
PHF	.000	.000	.000	.000	.000	.000	.000	.000	.000	.000	.250	.250	.000	.000	.000	.000	.250

County of San Bernardino
 N/S: Stanfield Cutoff
 E/W: North Shore Drive (SR-38)
 Weather: Clear

File Name : CSBSTSHPM
 Site Code : 05116469
 Start Date : 9/9/2016
 Page No : 2

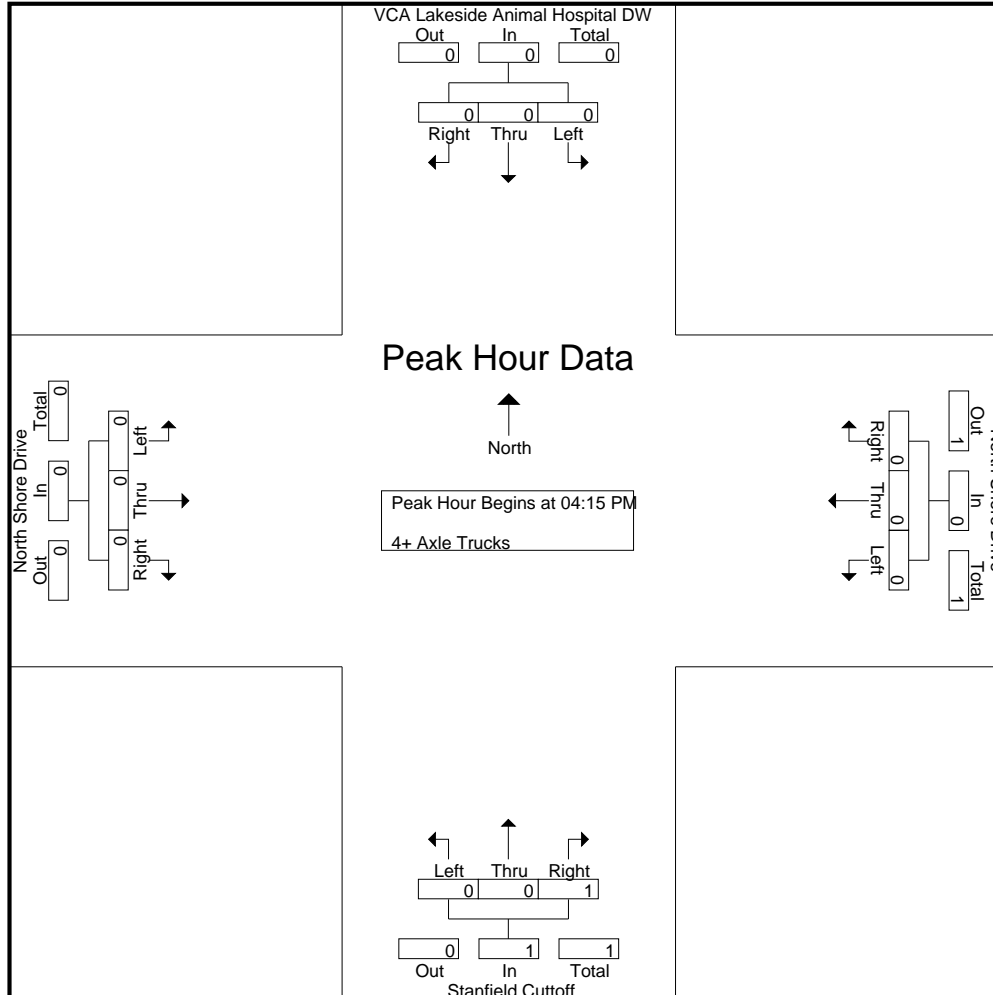

Counts Unlimited
 PO Box 1178
 Corona, CA 92878
 (951) 268-6268

County of San Bernardino
 N/S: Stanfield Cutoff
 E/W: North Shore Drive (SR-38)
 Weather: Clear

File Name : CSBSTSHPM
 Site Code : 05116469
 Start Date : 9/9/2016
 Page No : 3

Start Time	VCA Lakeside Animal Hospital DW Southbound				North Shore Drive Westbound				Stanfield Cutoff Northbound				North Shore Drive Eastbound				Int. Total
	Left	Thru	Right	App. Total	Left	Thru	Right	App. Total	Left	Thru	Right	App. Total	Left	Thru	Right	App. Total	
Peak Hour Analysis From 04:15 PM to 05:00 PM - Peak 1 of 1																	
Peak Hour for Each Approach Begins at:																	
	04:15 PM				04:15 PM				04:15 PM				04:15 PM				
+0 mins.	0	0	0	0	0	0	0	0	0	0	0	0	0	0	0	0	
+15 mins.	0	0	0	0	0	0	0	0	0	0	0	0	0	0	0	0	
+30 mins.	0	0	0	0	0	0	0	0	0	0	0	0	0	0	0	0	
+45 mins.	0	0	0	0	0	0	0	0	0	0	1	1	0	0	0	0	
Total Volume	0	0	0	0	0	0	0	0	0	0	1	1	0	0	0	0	
% App. Total	0	0	0	0	0	0	0	0	0	0	100	100	0	0	0	0	
PHF	.000	.000	.000	.000	.000	.000	.000	.000	.000	.000	.250	.250	.000	.000	.000	.000	

County of San Bernardino
 N/S: Stanfield Cutoff
 E/W: North Shore Drive (SR-38)
 Weather: Clear

File Name : CSBSTSHSUN
 Site Code : 05116469
 Start Date : 9/11/2016
 Page No : 1

Groups Printed- Passenger Vehicles - Large 2 Axle Vehicles - 3 Axle Vehicles - 4+ Axle Trucks

Start Time	VCA Lakeside Animal Hospital DW Southbound					North Shore Drive Westbound					Stanfield Cutoff Northbound					North Shore Drive Eastbound					Exclu. Total	Inclu. Total	Int. Total
	Left	Thru	Right	RTOR	App. Total	Left	Thru	Right	RTOR	App. Total	Left	Thru	Right	RTOR	App. Total	Left	Thru	Right	RTOR	App. Total			
12:00 PM	1	2	1	0	4	36	22	2	1	60	31	1	33	8	65	0	22	36	1	58	10	187	197
12:15 PM	7	0	1	0	8	78	27	2	0	107	39	0	35	11	74	0	22	36	1	58	12	247	259
12:30 PM	3	0	0	0	3	54	23	1	0	78	42	2	36	6	80	0	22	38	1	60	7	221	228
12:45 PM	1	0	1	0	2	32	26	1	1	59	40	5	51	8	96	0	26	30	1	56	10	213	223
Total	12	2	3	0	17	200	98	6	2	304	152	8	155	33	315	0	92	140	4	232	39	868	907
01:00 PM	1	0	1	0	2	38	18	1	0	57	41	4	32	6	77	0	14	23	0	37	6	173	179
01:15 PM	2	2	0	0	4	35	23	3	1	61	38	1	20	5	59	0	23	47	0	70	6	194	200
01:30 PM	1	1	0	0	2	38	28	3	0	69	40	1	32	8	73	0	25	27	0	52	8	196	204
01:45 PM	3	4	0	0	7	31	28	2	2	61	42	2	25	8	69	0	20	40	0	60	10	197	207
Total	7	7	1	0	15	142	97	9	3	248	161	8	109	27	278	0	82	137	0	219	30	760	790
Grand Total	19	9	4	0	32	342	195	15	5	552	313	16	264	60	593	0	174	277	4	451	69	1628	1697
Apprch %	59.4	28.1	12.5			62	35.3	2.7			52.8	2.7	44.5			0	38.6	61.4					
Total %	1.2	0.6	0.2		2	21	12	0.9		33.9	19.2	1	16.2		36.4	0	10.7	17		27.7	4.1	95.9	
Passenger Vehicles	19	9	4		32	338	194	15		552	311	16	263		650	0	169	272		443	0	0	1677
% Passenger Vehicles	100	100	100	0	100	98.8	99.5	100	100	99.1	99.4	100	99.6	100	99.5	0	97.1	98.2	50	97.4	0	0	98.8
Large 2 Axle Vehicles	0	0	0		0	2	1	0		3	2	0	1		3	0	5	4		11	0	0	17
% Large 2 Axle Vehicles	0	0	0	0	0	0.6	0.5	0	0	0.5	0.6	0	0.4	0	0.5	0	2.9	1.4	50	2.4	0	0	1
3 Axle Vehicles	0	0	0		0	2	0	0		2	0	0	0		0	0	0	0		0	0	0	2
% 3 Axle Vehicles	0	0	0	0	0	0.6	0	0	0	0.4	0	0	0	0	0	0	0	0	0	0	0	0	0.1
4+ Axle Trucks	0	0	0		0	0	0	0		0	0	0	0		0	0	0	1		1	0	0	1
% 4+ Axle Trucks	0	0	0	0	0	0	0	0	0	0	0	0	0	0	0	0	0	0.4	0	0.2	0	0	0.1

Start Time	VCA Lakeside Animal Hospital DW Southbound				North Shore Drive Westbound				Stanfield Cutoff Northbound				North Shore Drive Eastbound				Int. Total
	Left	Thru	Right	App. Total	Left	Thru	Right	App. Total	Left	Thru	Right	App. Total	Left	Thru	Right	App. Total	
12:00 PM	1	2	1	4	36	22	2	60	31	1	33	65	0	22	36	58	187
12:15 PM	7	0	1	8	78	27	2	107	39	0	35	74	0	22	36	58	247
12:30 PM	3	0	0	3	54	23	1	78	42	2	36	80	0	22	38	60	221
12:45 PM	1	0	1	2	32	26	1	59	40	5	51	96	0	26	30	56	213
Total Volume	12	2	3	17	200	98	6	304	152	8	155	315	0	92	140	232	868
% App. Total	70.6	11.8	17.6		65.8	32.2	2		48.3	2.5	49.2		0	39.7	60.3		
PHF	.429	.250	.750	.531	.641	.907	.750	.710	.905	.400	.760	.820	.000	.885	.921	.967	.879

Peak Hour Analysis From 12:00 PM to 01:45 PM - Peak 1 of 1
 Peak Hour for Entire Intersection Begins at 12:00 PM

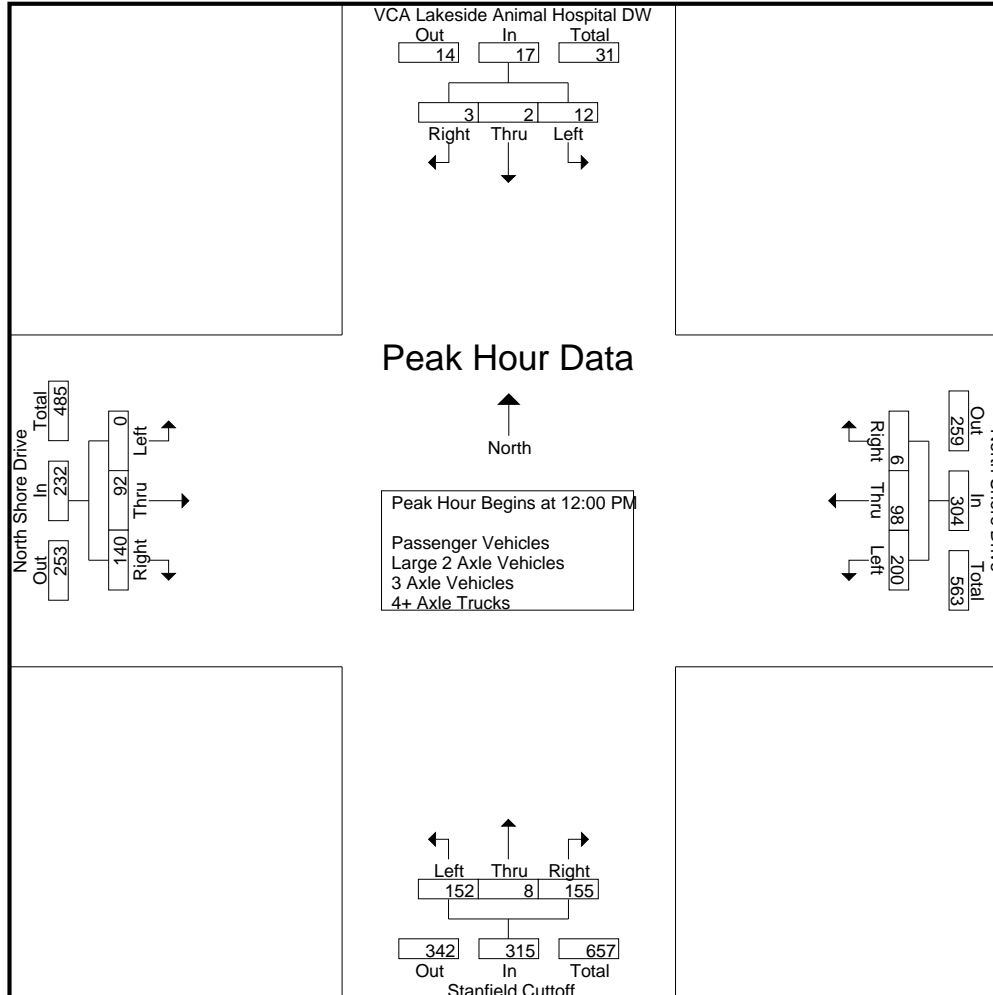

Counts Unlimited
 PO Box 1178
 Corona, CA 92878
 (951) 268-6268

County of San Bernardino
 N/S: Stanfield Cutoff
 E/W: North Shore Drive (SR-38)
 Weather: Clear

File Name : CSBSTSHSUN
 Site Code : 05116469
 Start Date : 9/11/2016
 Page No : 3

Start Time	VCA Lakeside Animal Hospital DW Southbound				North Shore Drive Westbound				Stanfield Cutoff Northbound				North Shore Drive Eastbound				Int. Total
	Left	Thru	Right	App. Total	Left	Thru	Right	App. Total	Left	Thru	Right	App. Total	Left	Thru	Right	App. Total	
Peak Hour Analysis From 12:00 PM to 01:45 PM - Peak 1 of 1																	
Peak Hour for Each Approach Begins at:																	
	12:00 PM				12:00 PM				12:15 PM				12:00 PM				
+0 mins.	1	2	1	4	36	22	2	60	39	0	35	74	0	22	36	58	
+15 mins.	7	0	1	8	78	27	2	107	42	2	36	80	0	22	36	58	
+30 mins.	3	0	0	3	54	23	1	78	40	5	51	96	0	22	38	60	
+45 mins.	1	0	1	2	32	26	1	59	41	4	32	77	0	26	30	56	
Total Volume	12	2	3	17	200	98	6	304	162	11	154	327	0	92	140	232	
% App. Total	70.6	11.8	17.6		65.8	32.2	2		49.5	3.4	47.1		0	39.7	60.3		
PHF	.429	.250	.750	.531	.641	.907	.750	.710	.964	.550	.755	.852	.000	.885	.921	.967	

Counts Unlimited
 PO Box 1178
 Corona, CA 92878
 (951) 268-6268

County of San Bernardino
 N/S: Stanfield Cutoff
 E/W: North Shore Drive (SR-38)
 Weather: Clear

File Name : CSBSTSHSUN
 Site Code : 05116469
 Start Date : 9/11/2016
 Page No : 1

Groups Printed- Passenger Vehicles

Start Time	VCA Lakeside Animal Hospital DW Southbound					North Shore Drive Westbound					Stanfield Cutoff Northbound					North Shore Drive Eastbound					Exclu. Total	Inclu. Total	Int. Total
	Left	Thru	Right	RTOR	App. Total	Left	Thru	Right	RTOR	App. Total	Left	Thru	Right	RTOR	App. Total	Left	Thru	Right	RTOR	App. Total			
12:00 PM	1	2	1	0	4	35	22	2	1	59	29	1	32	8	62	0	20	35	0	55	9	180	189
12:15 PM	7	0	1	0	8	75	27	2	0	104	39	0	35	11	74	0	22	36	1	58	12	244	256
12:30 PM	3	0	0	0	3	54	22	1	0	77	42	2	36	6	80	0	22	35	0	57	6	217	223
12:45 PM	1	0	1	0	2	32	26	1	1	59	40	5	51	8	96	0	26	29	1	55	10	212	222
Total	12	2	3	0	17	196	97	6	2	299	150	8	154	33	312	0	90	135	2	225	37	853	890
01:00 PM	1	0	1	0	2	38	18	1	0	57	41	4	32	6	77	0	13	23	0	36	6	172	178
01:15 PM	2	2	0	0	4	35	23	3	1	61	38	1	20	5	59	0	22	47	0	69	6	193	199
01:30 PM	1	1	0	0	2	38	28	3	0	69	40	1	32	8	73	0	25	27	0	52	8	196	204
01:45 PM	3	4	0	0	7	31	28	2	2	61	42	2	25	8	69	0	19	40	0	59	10	196	206
Total	7	7	1	0	15	142	97	9	3	248	161	8	109	27	278	0	79	137	0	216	30	757	787
Grand Total	19	9	4	0	32	338	194	15	5	547	311	16	263	60	590	0	169	272	2	441	67	1610	1677
Apprch %	59.4	28.1	12.5			61.8	35.5	2.7			52.7	2.7	44.6			0	38.3	61.7					
Total %	1.2	0.6	0.2		2	21	12	0.9		34	19.3	1	16.3		36.6	0	10.5	16.9		27.4	4	96	

Start Time	VCA Lakeside Animal Hospital DW Southbound				North Shore Drive Westbound				Stanfield Cutoff Northbound				North Shore Drive Eastbound				Int. Total
	Left	Thru	Right	App. Total	Left	Thru	Right	App. Total	Left	Thru	Right	App. Total	Left	Thru	Right	App. Total	
Peak Hour Analysis From 12:00 PM to 12:45 PM - Peak 1 of 1																	
Peak Hour for Entire Intersection Begins at 12:00 PM																	
12:00 PM	1	2	1	4	35	22	2	59	29	1	32	62	0	20	35	55	180
12:15 PM	7	0	1	8	75	27	2	104	39	0	35	74	0	22	36	58	244
12:30 PM	3	0	0	3	54	22	1	77	42	2	36	80	0	22	35	57	217
12:45 PM	1	0	1	2	32	26	1	59	40	5	51	96	0	26	29	55	212
Total Volume	12	2	3	17	196	97	6	299	150	8	154	312	0	90	135	225	853
% App. Total	70.6	11.8	17.6		65.6	32.4	2		48.1	2.6	49.4		0	40	60		
PHF	.429	.250	.750	.531	.653	.898	.750	.719	.893	.400	.755	.813	.000	.865	.938	.970	.874

County of San Bernardino
 N/S: Stanfield Cutoff
 E/W: North Shore Drive (SR-38)
 Weather: Clear

File Name : CSBSTSHSUN
 Site Code : 05116469
 Start Date : 9/11/2016
 Page No : 2

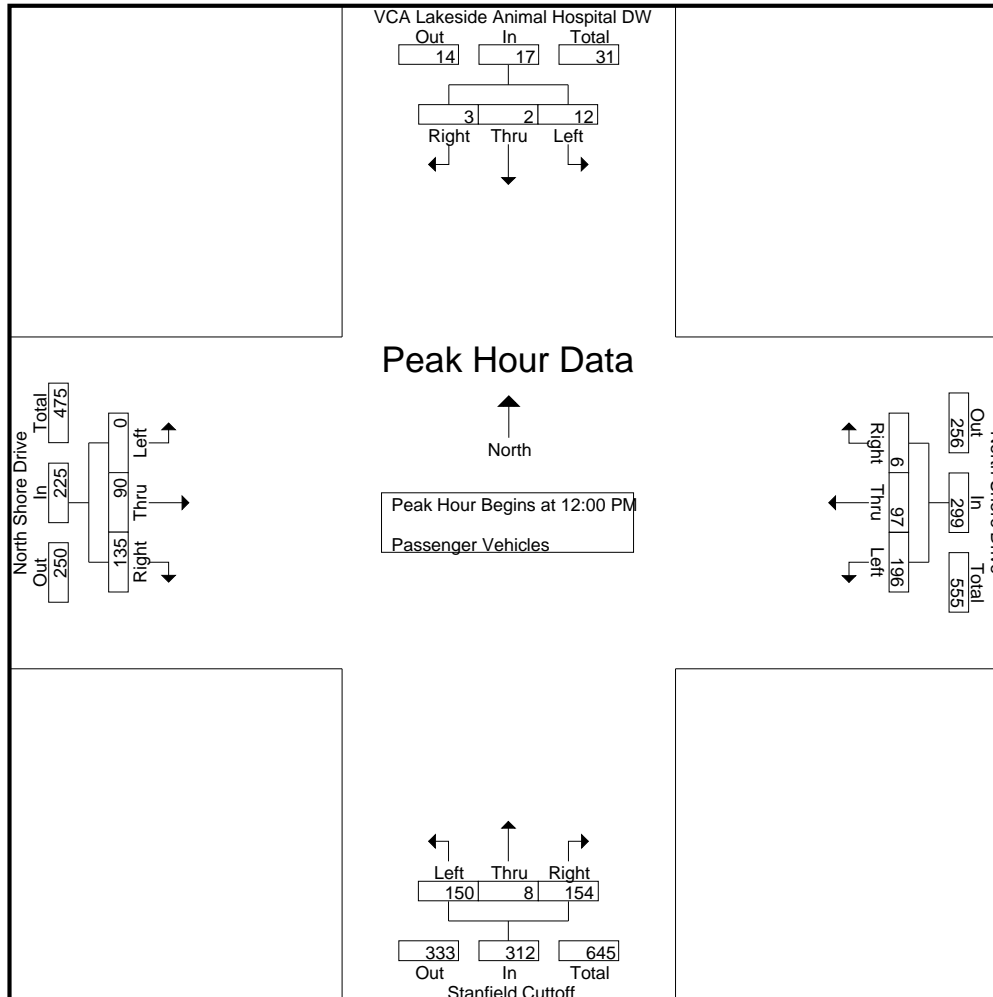

Counts Unlimited
 PO Box 1178
 Corona, CA 92878
 (951) 268-6268

County of San Bernardino
 N/S: Stanfield Cutoff
 E/W: North Shore Drive (SR-38)
 Weather: Clear

File Name : CSBSTSHSUN
 Site Code : 05116469
 Start Date : 9/11/2016
 Page No : 3

Start Time	VCA Lakeside Animal Hospital DW Southbound				North Shore Drive Westbound				Stanfield Cutoff Northbound				North Shore Drive Eastbound				Int. Total
	Left	Thru	Right	App. Total	Left	Thru	Right	App. Total	Left	Thru	Right	App. Total	Left	Thru	Right	App. Total	
Peak Hour Analysis From 12:00 PM to 12:45 PM - Peak 1 of 1																	
Peak Hour for Each Approach Begins at:																	
	12:00 PM				12:00 PM				12:00 PM				12:00 PM				
+0 mins.	1	2	1	4	35	22	2	59	29	1	32	62	0	20	35	55	
+15 mins.	7	0	1	8	75	27	2	104	39	0	35	74	0	22	36	58	
+30 mins.	3	0	0	3	54	22	1	77	42	2	36	80	0	22	35	57	
+45 mins.	1	0	1	2	32	26	1	59	40	5	51	96	0	26	29	55	
Total Volume	12	2	3	17	196	97	6	299	150	8	154	312	0	90	135	225	
% App. Total	70.6	11.8	17.6		65.6	32.4	2		48.1	2.6	49.4		0	40	60		
PHF	.429	.250	.750	.531	.653	.898	.750	.719	.893	.400	.755	.813	.000	.865	.938	.970	

Counts Unlimited
 PO Box 1178
 Corona, CA 92878
 (951) 268-6268

County of San Bernardino
 N/S: Stanfield Cutoff
 E/W: North Shore Drive (SR-38)
 Weather: Clear

File Name : CSBSTSHSUN
 Site Code : 05116469
 Start Date : 9/11/2016
 Page No : 1

Groups Printed- Large 2 Axle Vehicles

Start Time	VCA Lakeside Animal Hospital DW Southbound					North Shore Drive Westbound					Stanfield Cutoff Northbound					North Shore Drive Eastbound					Exclu. Total	Inclu. Total	Int. Total
	Left	Thru	Right	RTOR	App. Total	Left	Thru	Right	RTOR	App. Total	Left	Thru	Right	RTOR	App. Total	Left	Thru	Right	RTOR	App. Total			
12:00 PM	0	0	0	0	0	0	0	0	0	0	2	0	1	0	3	0	2	1	1	3	1	6	7
12:15 PM	0	0	0	0	0	2	0	0	0	2	0	0	0	0	0	0	0	0	0	0	0	2	2
12:30 PM	0	0	0	0	0	0	1	0	0	1	0	0	0	0	0	0	0	2	1	2	1	3	4
12:45 PM	0	0	0	0	0	0	0	0	0	0	0	0	0	0	0	0	0	1	0	1	0	1	1
Total	0	0	0	0	0	2	1	0	0	3	2	0	1	0	3	0	2	4	2	6	2	12	14
01:00 PM	0	0	0	0	0	0	0	0	0	0	0	0	0	0	0	0	1	0	0	1	0	1	1
01:15 PM	0	0	0	0	0	0	0	0	0	0	0	0	0	0	0	0	1	0	0	1	0	1	1
01:30 PM	0	0	0	0	0	0	0	0	0	0	0	0	0	0	0	0	0	0	0	0	0	0	0
01:45 PM	0	0	0	0	0	0	0	0	0	0	0	0	0	0	0	0	1	0	0	1	0	1	1
Total	0	0	0	0	0	0	0	0	0	0	0	0	0	0	0	0	3	0	0	3	0	3	3
Grand Total	0	0	0	0	0	2	1	0	0	3	2	0	1	0	3	0	5	4	2	9	2	15	17
Apprch %	0	0	0			66.7	33.3	0			66.7	0	33.3			0	55.6	44.4					
Total %	0	0	0			13.3	6.7	0		20	13.3	0	6.7		20	0	33.3	26.7		60	11.8	88.2	

Start Time	VCA Lakeside Animal Hospital DW Southbound				North Shore Drive Westbound				Stanfield Cutoff Northbound				North Shore Drive Eastbound				Int. Total
	Left	Thru	Right	App. Total	Left	Thru	Right	App. Total	Left	Thru	Right	App. Total	Left	Thru	Right	App. Total	
Peak Hour Analysis From 12:00 PM to 12:45 PM - Peak 1 of 1																	
Peak Hour for Entire Intersection Begins at 12:00 PM																	
12:00 PM	0	0	0	0	0	0	0	0	2	0	1	3	0	2	1	3	6
12:15 PM	0	0	0	0	2	0	0	2	0	0	0	0	0	0	0	0	2
12:30 PM	0	0	0	0	0	1	0	1	0	0	0	0	0	0	2	2	3
12:45 PM	0	0	0	0	0	0	0	0	0	0	0	0	0	0	1	1	1
Total Volume	0	0	0	0	2	1	0	3	2	0	1	3	0	2	4	6	12
% App. Total	0	0	0	0	66.7	33.3	0		66.7	0	33.3		0	33.3	66.7		
PHF	.000	.000	.000	.000	.250	.250	.000	.375	.250	.000	.250	.250	.000	.250	.500	.500	.500

County of San Bernardino
 N/S: Stanfield Cutoff
 E/W: North Shore Drive (SR-38)
 Weather: Clear

File Name : CSBSTSHSUN
 Site Code : 05116469
 Start Date : 9/11/2016
 Page No : 2

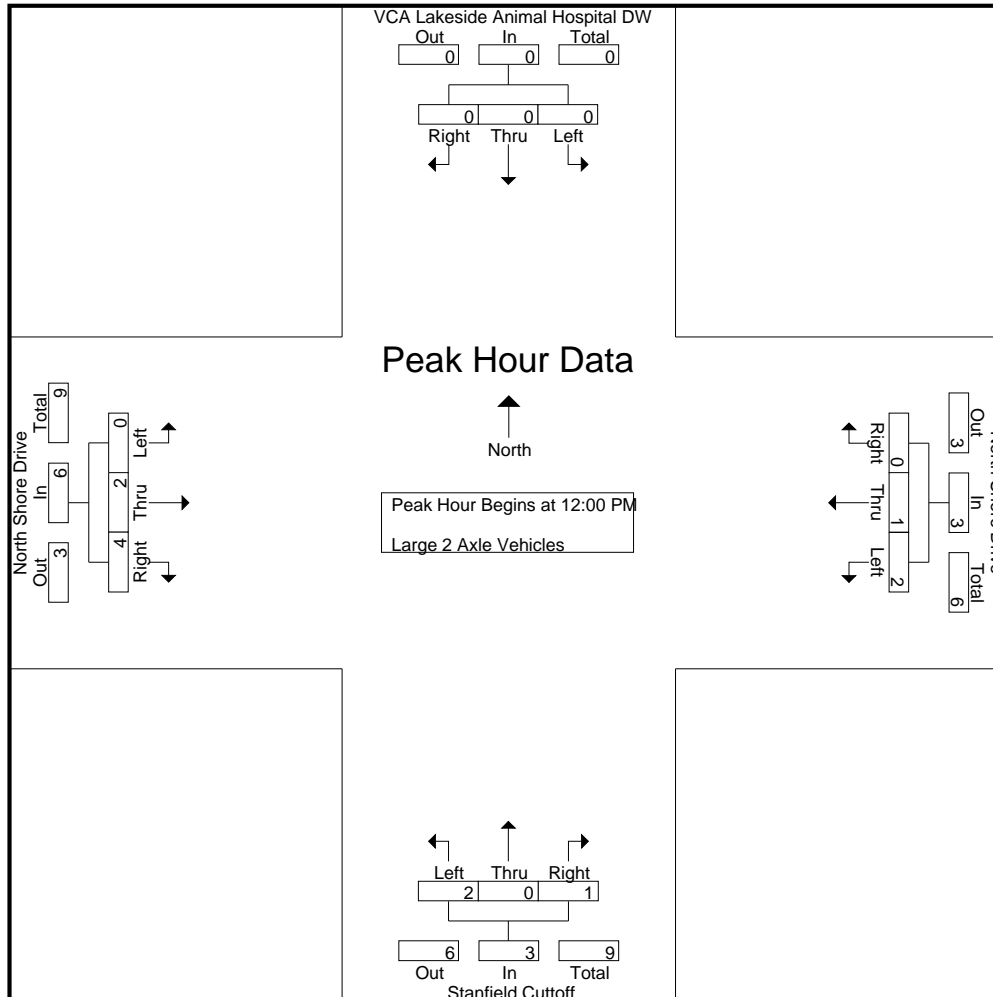

Counts Unlimited
 PO Box 1178
 Corona, CA 92878
 (951) 268-6268

County of San Bernardino
 N/S: Stanfield Cutoff
 E/W: North Shore Drive (SR-38)
 Weather: Clear

File Name : CSBSTSHSUN
 Site Code : 05116469
 Start Date : 9/11/2016
 Page No : 3

Start Time	VCA Lakeside Animal Hospital DW Southbound				North Shore Drive Westbound				Stanfield Cutoff Northbound				North Shore Drive Eastbound				Int. Total
	Left	Thru	Right	App. Total	Left	Thru	Right	App. Total	Left	Thru	Right	App. Total	Left	Thru	Right	App. Total	
Peak Hour Analysis From 12:00 PM to 12:45 PM - Peak 1 of 1																	
Peak Hour for Each Approach Begins at:																	
	12:00 PM				12:00 PM				12:00 PM				12:00 PM				
+0 mins.	0	0	0	0	0	0	0	0	2	0	1	3	0	2	1	3	
+15 mins.	0	0	0	0	2	0	0	2	0	0	0	0	0	0	0	0	
+30 mins.	0	0	0	0	0	1	0	1	0	0	0	0	0	0	2	2	
+45 mins.	0	0	0	0	0	0	0	0	0	0	0	0	0	0	1	1	
Total Volume	0	0	0	0	2	1	0	3	2	0	1	3	0	2	4	6	
% App. Total	0	0	0	0	66.7	33.3	0		66.7	0	33.3		0	33.3	66.7		
PHF	.000	.000	.000	.000	.250	.250	.000	.375	.250	.000	.250	.250	.000	.250	.500	.500	

Counts Unlimited
 PO Box 1178
 Corona, CA 92878
 (951) 268-6268

County of San Bernardino
 N/S: Stanfield Cutoff
 E/W: North Shore Drive (SR-38)
 Weather: Clear

File Name : CSBSTSHSUN
 Site Code : 05116469
 Start Date : 9/11/2016
 Page No : 1

Groups Printed- 3 Axle Vehicles

Start Time	VCA Lakeside Animal Hospital DW Southbound					North Shore Drive Westbound					Stanfield Cutoff Northbound					North Shore Drive Eastbound					Exclu. Total	Inclu. Total	Int. Total					
	Left	Thru	Right	RTOR	App. Total	Left	Thru	Right	RTOR	App. Total	Left	Thru	Right	RTOR	App. Total	Left	Thru	Right	RTOR	App. Total								
12:00 PM	0	0	0	0	0	1	0	0	0	1	0	0	0	0	0	0	0	0	0	0	0	0	0	0	0	0	1	1
12:15 PM	0	0	0	0	0	1	0	0	0	1	0	0	0	0	0	0	0	0	0	0	0	0	0	0	0	0	1	1
12:30 PM	0	0	0	0	0	0	0	0	0	0	0	0	0	0	0	0	0	0	0	0	0	0	0	0	0	0	0	0
12:45 PM	0	0	0	0	0	0	0	0	0	0	0	0	0	0	0	0	0	0	0	0	0	0	0	0	0	0	0	0
Total	0	0	0	0	0	2	0	0	0	2	0	0	0	0	0	0	0	0	0	0	0	0	0	0	0	0	2	2
01:00 PM	0	0	0	0	0	0	0	0	0	0	0	0	0	0	0	0	0	0	0	0	0	0	0	0	0	0	0	0
01:15 PM	0	0	0	0	0	0	0	0	0	0	0	0	0	0	0	0	0	0	0	0	0	0	0	0	0	0	0	0
01:30 PM	0	0	0	0	0	0	0	0	0	0	0	0	0	0	0	0	0	0	0	0	0	0	0	0	0	0	0	0
01:45 PM	0	0	0	0	0	0	0	0	0	0	0	0	0	0	0	0	0	0	0	0	0	0	0	0	0	0	0	0
Total	0	0	0	0	0	0	0	0	0	0	0	0	0	0	0	0	0	0	0	0	0	0	0	0	0	0	0	0
Grand Total	0	0	0	0	0	2	0	0	0	2	0	0	0	0	0	0	0	0	0	0	0	0	0	0	0	0	2	2
Apprch %	0	0	0			100	0	0			0	0	0			0	0	0			0	0	0					
Total %	0	0	0		0	100	0	0		100	0	0	0		0	0	0	0		0	0	0	0		0	0	100	

Start Time	VCA Lakeside Animal Hospital DW Southbound				North Shore Drive Westbound				Stanfield Cutoff Northbound				North Shore Drive Eastbound				Int. Total
	Left	Thru	Right	App. Total	Left	Thru	Right	App. Total	Left	Thru	Right	App. Total	Left	Thru	Right	App. Total	
Peak Hour Analysis From 12:00 PM to 12:45 PM - Peak 1 of 1																	
Peak Hour for Entire Intersection Begins at 12:00 PM																	
12:00 PM	0	0	0	0	1	0	0	1	0	0	0	0	0	0	0	0	1
12:15 PM	0	0	0	0	1	0	0	1	0	0	0	0	0	0	0	0	1
12:30 PM	0	0	0	0	0	0	0	0	0	0	0	0	0	0	0	0	0
12:45 PM	0	0	0	0	0	0	0	0	0	0	0	0	0	0	0	0	0
Total Volume	0	0	0	0	2	0	0	2	0	0	0	0	0	0	0	0	2
% App. Total	0	0	0	0	100	0	0	100	0	0	0	0	0	0	0	0	100
PHF	.000	.000	.000	.000	.500	.000	.000	.500	.000	.000	.000	.000	.000	.000	.000	.000	.500

County of San Bernardino
 N/S: Stanfield Cutoff
 E/W: North Shore Drive (SR-38)
 Weather: Clear

File Name : CSBSTSHSUN
 Site Code : 05116469
 Start Date : 9/11/2016
 Page No : 2

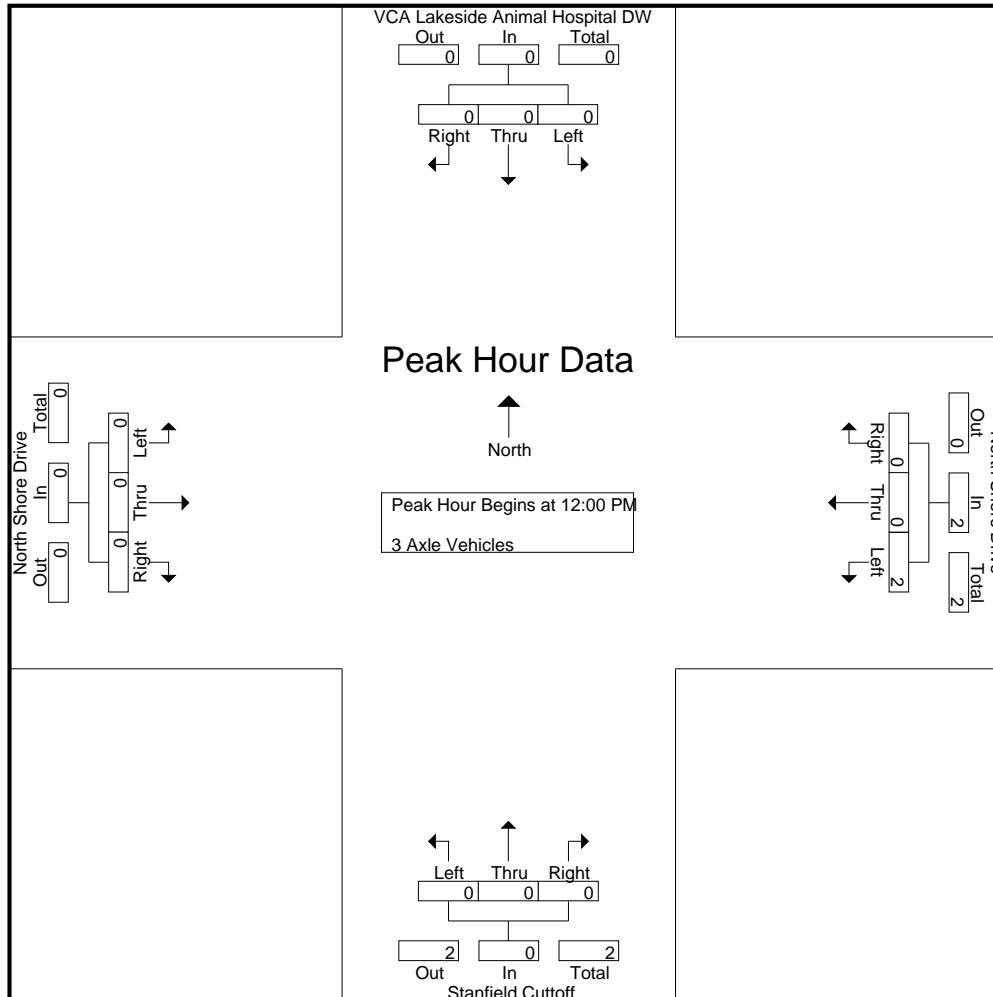

Counts Unlimited
 PO Box 1178
 Corona, CA 92878
 (951) 268-6268

County of San Bernardino
 N/S: Stanfield Cutoff
 E/W: North Shore Drive (SR-38)
 Weather: Clear

File Name : CSBSTSHSUN
 Site Code : 05116469
 Start Date : 9/11/2016
 Page No : 1

Groups Printed- 4+ Axle Trucks

Start Time	VCA Lakeside Animal Hospital DW Southbound					North Shore Drive Westbound					Stanfield Cutoff Northbound					North Shore Drive Eastbound					Exclu. Total	Inclu. Total	Int. Total					
	Left	Thru	Right	RTOR	App. Total	Left	Thru	Right	RTOR	App. Total	Left	Thru	Right	RTOR	App. Total	Left	Thru	Right	RTOR	App. Total								
12:00 PM	0	0	0	0	0	0	0	0	0	0	0	0	0	0	0	0	0	0	0	0	0	0	0	0	0	0	0	0
12:15 PM	0	0	0	0	0	0	0	0	0	0	0	0	0	0	0	0	0	0	0	0	0	0	0	0	0	0	0	0
12:30 PM	0	0	0	0	0	0	0	0	0	0	0	0	0	0	0	0	0	1	0	1	0	0	1	0	1	0	0	1
12:45 PM	0	0	0	0	0	0	0	0	0	0	0	0	0	0	0	0	0	0	0	0	0	0	0	0	0	0	0	0
Total	0	0	0	0	0	0	0	0	0	0	0	0	0	0	0	0	0	1	0	1	0	0	1	0	1	0	0	1
01:00 PM	0	0	0	0	0	0	0	0	0	0	0	0	0	0	0	0	0	0	0	0	0	0	0	0	0	0	0	0
01:15 PM	0	0	0	0	0	0	0	0	0	0	0	0	0	0	0	0	0	0	0	0	0	0	0	0	0	0	0	0
01:30 PM	0	0	0	0	0	0	0	0	0	0	0	0	0	0	0	0	0	0	0	0	0	0	0	0	0	0	0	0
01:45 PM	0	0	0	0	0	0	0	0	0	0	0	0	0	0	0	0	0	0	0	0	0	0	0	0	0	0	0	0
Total	0	0	0	0	0	0	0	0	0	0	0	0	0	0	0	0	0	0	0	0	0	0	0	0	0	0	0	0
Grand Total	0	0	0	0	0	0	0	0	0	0	0	0	0	0	0	0	0	1	0	1	0	0	1	0	1	0	0	1
Apprch %	0	0	0			0	0	0			0	0	0			0	0	100										
Total %	0	0	0			0	0	0			0	0	0			0	0	100		100						0	100	

Start Time	VCA Lakeside Animal Hospital DW Southbound				North Shore Drive Westbound				Stanfield Cutoff Northbound				North Shore Drive Eastbound				Int. Total				
	Left	Thru	Right	App. Total	Left	Thru	Right	App. Total	Left	Thru	Right	App. Total	Left	Thru	Right	App. Total					
Peak Hour Analysis From 12:00 PM to 12:45 PM - Peak 1 of 1																					
Peak Hour for Entire Intersection Begins at 12:00 PM																					
12:00 PM	0	0	0	0	0	0	0	0	0	0	0	0	0	0	0	0	0	0	0	0	0
12:15 PM	0	0	0	0	0	0	0	0	0	0	0	0	0	0	0	0	0	0	0	0	0
12:30 PM	0	0	0	0	0	0	0	0	0	0	0	0	0	0	1	1	1	1	1	1	1
12:45 PM	0	0	0	0	0	0	0	0	0	0	0	0	0	0	0	0	0	0	0	0	0
Total Volume	0	0	0	0	0	0	0	0	0	0	0	0	0	0	1	1	1	1	1	1	1
% App. Total	0	0	0		0	0	0		0	0	0		0	0	100						
PHF	.000	.000	.000	.000	.000	.000	.000	.000	.000	.000	.000	.000	.000	.000	.250	.250	.250	.250	.250	.250	.250

County of San Bernardino
 N/S: Stanfield Cutoff
 E/W: North Shore Drive (SR-38)
 Weather: Clear

File Name : CSBSTSHSUN
 Site Code : 05116469
 Start Date : 9/11/2016
 Page No : 2

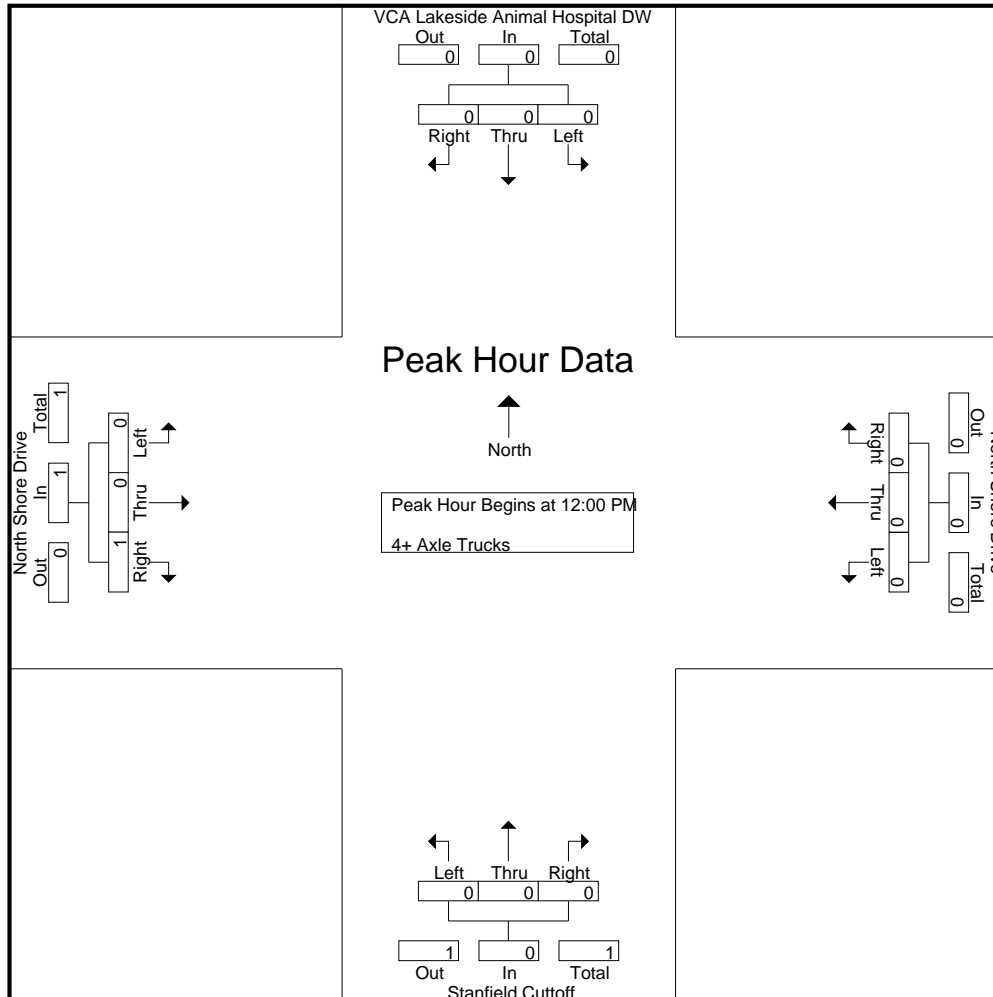

Counts Unlimited
 PO Box 1178
 Corona, CA 92878
 (951) 268-6268

County of San Bernardino
 N/S: Stanfield Cutoff
 E/W: North Shore Drive (SR-38)
 Weather: Clear

File Name : CSBSTSHSUN
 Site Code : 05116469
 Start Date : 9/11/2016
 Page No : 3

Start Time	VCA Lakeside Animal Hospital DW Southbound				North Shore Drive Westbound				Stanfield Cutoff Northbound				North Shore Drive Eastbound				Int. Total
	Left	Thru	Right	App. Total	Left	Thru	Right	App. Total	Left	Thru	Right	App. Total	Left	Thru	Right	App. Total	
Peak Hour Analysis From 12:00 PM to 12:45 PM - Peak 1 of 1																	
Peak Hour for Each Approach Begins at:																	
	12:00 PM				12:00 PM				12:00 PM				12:00 PM				
+0 mins.	0	0	0	0	0	0	0	0	0	0	0	0	0	0	0	0	
+15 mins.	0	0	0	0	0	0	0	0	0	0	0	0	0	0	0	0	
+30 mins.	0	0	0	0	0	0	0	0	0	0	0	0	0	0	1	1	
+45 mins.	0	0	0	0	0	0	0	0	0	0	0	0	0	0	0	0	
Total Volume	0	0	0	0	0	0	0	0	0	0	0	0	0	0	1	1	
% App. Total	0	0	0	0	0	0	0	0	0	0	0	0	0	0	100		
PHF	.000	.000	.000	.000	.000	.000	.000	.000	.000	.000	.000	.000	.000	.000	.250	.250	

Location: County of San Bernardino
 N/S: Stanfield Cutoff
 E/W: North Shore Drive (SR-38)



PEDESTRIANS

Date: 9/9/2016

Day: Friday

	North Leg VCA Lakeside Animal Hospital DW	East Leg North Shore Drive (SR-38)	South Leg Stanfield Cutoff	West Leg North Shore Drive (SR-38)	TOTAL
4:00 PM	0	0	0	0	0
4:15 PM	0	0	0	0	0
4:30 PM	0	0	0	0	0
4:45 PM	0	0	0	0	0
5:00 PM	0	0	0	0	0
5:15 PM	0	0	0	0	0
5:30 PM	0	0	0	0	0
5:45 PM	0	0	0	0	0
TOTAL VOLUMES:	0	0	0	0	0

Date: 9/11/2016

Day: Sunday

	North Leg VCA Lakeside Animal Hospital DW	East Leg North Shore Drive (SR-38)	South Leg Stanfield Cutoff	West Leg North Shore Drive (SR-38)	TOTAL
12:00 PM	0	0	2	3	5
12:15 PM	6	0	0	6	12
12:30 PM	2	0	0	1	3
12:45 PM	0	0	0	5	5
1:00 PM	2	0	0	1	3
1:15 PM	0	0	0	0	0
1:30 PM	1	3	0	2	6
1:45 PM	0	0	1	0	1
TOTAL VOLUMES:	11	3	3	18	35

Location: County of San Bernardino
 N/S: Stanfield Cutoff
 E/W: North Shore Drive (SR-38)



BICYCLES

Date: 9/9/2016

Day: Friday

	North Leg VCA Lakeside Animal Hospital DW	East Leg North Shore Drive (SR-38)	South Leg Stanfield Cutoff	West Leg North Shore Drive (SR-38)	TOTAL
4:00 PM	0	0	0	0	0
4:15 PM	0	0	0	0	0
4:30 PM	0	0	0	0	0
4:45 PM	2	0	0	0	2
5:00 PM	0	0	0	0	0
5:15 PM	0	0	0	0	0
5:30 PM	0	0	0	0	0
5:45 PM	0	0	0	0	0
TOTAL VOLUMES:	2	0	0	0	2

Date: 9/11/2016

Day: Sunday

	North Leg VCA Lakeside Animal Hospital DW	East Leg North Shore Drive (SR-38)	South Leg Stanfield Cutoff	West Leg North Shore Drive (SR-38)	TOTAL
12:00 PM	0	0	0	0	0
12:15 PM	0	0	2	0	2
12:30 PM	1	0	0	0	1
12:45 PM	0	0	0	0	0
1:00 PM	0	0	0	0	0
1:15 PM	0	0	0	0	0
1:30 PM	0	0	0	0	0
1:45 PM	0	0	0	0	0
TOTAL VOLUMES:	1	0	2	0	3

City of Big Bear Lake
 N/S: Stanfield Cutoff/Starvation Flats
 E/W: Big Bear Boulevard (SR-18)
 Weather: Clear

File Name : BBLSTBIPM
 Site Code : 05116469
 Start Date : 9/9/2016
 Page No : 1

Groups Printed- Passenger Vehicles - Large 2 Axle Vehicles - 3 Axle Vehicles - 4+ Axle Trucks

Start Time	Stanfield Cutoff Southbound					Big Bear Boulevard Westbound					Starvation Flats Road Northbound					Big Bear Boulevard Eastbound					Exclu. Total	Inclu. Total	Int. Total
	Left	Thru	Right	RTOR	App. Total	Left	Thru	Right	RTOR	App. Total	Left	Thru	Right	RTOR	App. Total	Left	Thru	Right	RTOR	App. Total			
04:00 PM	4	6	63	42	73	8	139	1	1	148	8	8	21	18	37	45	172	10	0	227	61	485	546
04:15 PM	1	9	64	36	74	7	130	1	0	138	12	11	14	12	37	53	165	9	0	227	48	476	524
04:30 PM	1	5	73	41	79	9	154	6	2	169	9	4	16	9	29	53	171	6	1	230	53	507	560
04:45 PM	4	8	59	42	71	5	143	4	0	152	10	9	16	13	35	60	182	10	0	252	55	510	565
Total	10	28	259	161	297	29	566	12	3	607	39	32	67	52	138	211	690	35	1	936	217	1978	2195
05:00 PM	2	5	61	27	68	7	136	8	0	151	9	15	14	9	38	49	194	12	2	255	38	512	550
05:15 PM	4	4	54	41	62	4	128	6	1	138	10	7	8	6	25	70	174	13	0	257	48	482	530
05:30 PM	3	2	61	45	66	4	105	3	0	112	9	4	9	8	22	43	187	3	0	233	53	433	486
05:45 PM	2	4	56	36	62	4	111	4	1	119	6	6	7	7	19	51	183	9	0	243	44	443	487
Total	11	15	232	149	258	19	480	21	2	520	34	32	38	30	104	213	738	37	2	988	183	1870	2053
Grand Total	21	43	491	310	555	48	1046	33	5	1127	73	64	105	82	242	424	1428	72	3	1924	400	3848	4248
Apprch %	3.8	7.7	88.5			4.3	92.8	2.9			30.2	26.4	43.4			22	74.2	3.7					
Total %	0.5	1.1	12.8		14.4	1.2	27.2	0.9		29.3	1.9	1.7	2.7		6.3	11	37.1	1.9		50	9.4	90.6	
Passenger Vehicles	21	43	474		840	48	1025	33		1111	71	62	102		315	421	1401	68		1892	0	0	4158
% Passenger Vehicles	100	100	96.5	97.4	97.1	100	98	100	100	98.1	97.3	96.9	97.1	97.6	97.2	99.3	98.1	94.4	66.7	98.2	0	0	97.9
Large 2 Axle Vehicles	0	0	10		11	0	16	0		16	1	0	2		4	1	21	4		27	0	0	58
% Large 2 Axle Vehicles	0	0	2	0.3	1.3	0	1.5	0	0	1.4	1.4	0	1.9	1.2	1.2	0.2	1.5	5.6	33.3	1.4	0	0	1.4
3 Axle Vehicles	0	0	7		12	0	3	0		3	1	2	1		4	1	4	0		5	0	0	24
% 3 Axle Vehicles	0	0	1.4	1.6	1.4	0	0.3	0	0	0.3	1.4	3.1	1	0	1.2	0.2	0.3	0	0	0.3	0	0	0.6
4+ Axle Trucks	0	0	0		2	0	2	0		2	0	0	0		1	1	2	0		3	0	0	8
% 4+ Axle Trucks	0	0	0	0.6	0.2	0	0.2	0	0	0.2	0	0	0	1.2	0.3	0.2	0.1	0	0	0.2	0	0	0.2

Start Time	Stanfield Cutoff Southbound				Big Bear Boulevard Westbound				Starvation Flats Road Northbound				Big Bear Boulevard Eastbound				Int. Total
	Left	Thru	Right	App. Total	Left	Thru	Right	App. Total	Left	Thru	Right	App. Total	Left	Thru	Right	App. Total	
Peak Hour Analysis From 04:00 PM to 05:45 PM - Peak 1 of 1																	
Peak Hour for Entire Intersection Begins at 04:30 PM																	
04:30 PM	1	5	73	79	9	154	6	169	9	4	16	29	53	171	6	230	507
04:45 PM	4	8	59	71	5	143	4	152	10	9	16	35	60	182	10	252	510
05:00 PM	2	5	61	68	7	136	8	151	9	15	14	38	49	194	12	255	512
05:15 PM	4	4	54	62	4	128	6	138	10	7	8	25	70	174	13	257	482
Total Volume	11	22	247	280	25	561	24	610	38	35	54	127	232	721	41	994	2011
% App. Total	3.9	7.9	88.2		4.1	92	3.9		29.9	27.6	42.5		23.3	72.5	4.1		
PHF	.688	.688	.846	.886	.694	.911	.750	.902	.950	.583	.844	.836	.829	.929	.788	.967	.982

City of Big Bear Lake
 N/S: Stanfield Cutoff/Starvation Flats
 E/W: Big Bear Boulevard (SR-18)
 Weather: Clear

File Name : BBLSTBIPM
 Site Code : 05116469
 Start Date : 9/9/2016
 Page No : 2

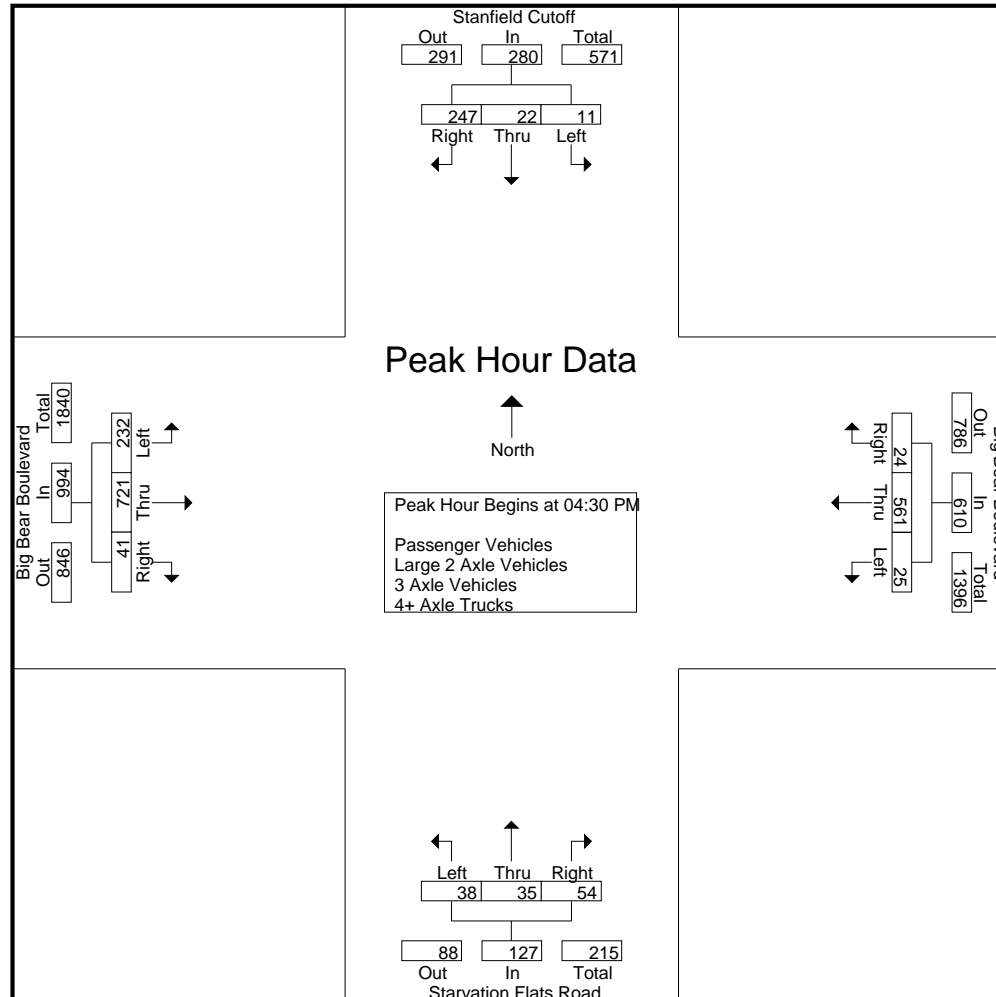

Counts Unlimited
 PO Box 1178
 Corona, CA 92878
 (951) 268-6268

City of Big Bear Lake
 N/S: Stanfield Cutoff/Starvation Flats
 E/W: Big Bear Boulevard (SR-18)
 Weather: Clear

File Name : BBLSTBIPM
 Site Code : 05116469
 Start Date : 9/9/2016
 Page No : 3

Start Time	Stanfield Cutoff Southbound				Big Bear Boulevard Westbound				Starvation Flats Road Northbound				Big Bear Boulevard Eastbound				Int. Total
	Left	Thru	Right	App. Total	Left	Thru	Right	App. Total	Left	Thru	Right	App. Total	Left	Thru	Right	App. Total	
Peak Hour Analysis From 04:00 PM to 05:45 PM - Peak 1 of 1																	
Peak Hour for Each Approach Begins at:																	
	04:00 PM				04:15 PM				04:15 PM				04:45 PM				
+0 mins.	4	6	63	73	7	130	1	138	12	11	14	37	60	182	10	252	
+15 mins.	1	9	64	74	9	154	6	169	9	4	16	29	49	194	12	255	
+30 mins.	1	5	73	79	5	143	4	152	10	9	16	35	70	174	13	257	
+45 mins.	4	8	59	71	7	136	8	151	9	15	14	38	43	187	3	233	
Total Volume	10	28	259	297	28	563	19	610	40	39	60	139	222	737	38	997	
% App. Total	3.4	9.4	87.2		4.6	92.3	3.1		28.8	28.1	43.2		22.3	73.9	3.8		
PHF	.625	.778	.887	.940	.778	.914	.594	.902	.833	.650	.938	.914	.793	.950	.731	.970	

City of Big Bear Lake
 N/S: Stanfield Cutoff/Starvation Flats
 E/W: Big Bear Boulevard (SR-18)
 Weather: Clear

File Name : BBLSTBIPM
 Site Code : 05116469
 Start Date : 9/9/2016
 Page No : 1

Groups Printed- Passenger Vehicles

Start Time	Stanfield Cutoff Southbound					Big Bear Boulevard Westbound					Starvation Flats Road Northbound					Big Bear Boulevard Eastbound					Exclu. Total	Inclu. Total	Int. Total
	Left	Thru	Right	RTOR	App. Total	Left	Thru	Right	RTOR	App. Total	Left	Thru	Right	RTOR	App. Total	Left	Thru	Right	RTOR	App. Total			
04:00 PM	4	6	61	40	71	8	135	1	1	144	8	7	19	17	34	45	169	9	0	223	58	472	530
04:15 PM	1	9	60	35	70	7	128	1	0	136	12	10	14	12	36	53	159	8	0	220	47	462	509
04:30 PM	1	5	73	41	79	9	149	6	2	164	9	4	16	9	29	53	168	6	1	227	53	499	552
04:45 PM	4	8	59	42	71	5	138	4	0	147	9	9	16	13	34	60	178	10	0	248	55	500	555
Total	10	28	253	158	291	29	550	12	3	591	38	30	65	51	133	211	674	33	1	918	213	1933	2146
05:00 PM	2	5	60	27	67	7	135	8	0	150	9	15	13	9	37	47	190	10	1	247	37	501	538
05:15 PM	4	4	48	38	56	4	128	6	1	138	10	7	8	6	25	69	170	13	0	252	45	471	516
05:30 PM	3	2	58	44	63	4	104	3	0	111	8	4	9	7	21	43	186	3	0	232	51	427	478
05:45 PM	2	4	55	35	61	4	108	4	1	116	6	6	7	7	19	51	181	9	0	241	43	437	480
Total	11	15	221	144	247	19	475	21	2	515	33	32	37	29	102	210	727	35	1	972	176	1836	2012
Grand Total	21	43	474	302	538	48	1025	33	5	1106	71	62	102	80	235	421	1401	68	2	1890	389	3769	4158
Apprch %	3.9	8	88.1			4.3	92.7	3			30.2	26.4	43.4			22.3	74.1	3.6					
Total %	0.6	1.1	12.6		14.3	1.3	27.2	0.9		29.3	1.9	1.6	2.7		6.2	11.2	37.2	1.8		50.1	9.4	90.6	

Start Time	Stanfield Cutoff Southbound				Big Bear Boulevard Westbound				Starvation Flats Road Northbound				Big Bear Boulevard Eastbound				Int. Total
	Left	Thru	Right	App. Total	Left	Thru	Right	App. Total	Left	Thru	Right	App. Total	Left	Thru	Right	App. Total	
Peak Hour Analysis From 04:30 PM to 05:15 PM - Peak 1 of 1																	
Peak Hour for Entire Intersection Begins at 04:30 PM																	
04:30 PM	1	5	73	79	9	149	6	164	9	4	16	29	53	168	6	227	499
04:45 PM	4	8	59	71	5	138	4	147	9	9	16	34	60	178	10	248	500
05:00 PM	2	5	60	67	7	135	8	150	9	15	13	37	47	190	10	247	501
05:15 PM	4	4	48	56	4	128	6	138	10	7	8	25	69	170	13	252	471
Total Volume	11	22	240	273	25	550	24	599	37	35	53	125	229	706	39	974	1971
% App. Total	4	8.1	87.9		4.2	91.8	4		29.6	28	42.4		23.5	72.5	4		
PHF	.688	.688	.822	.864	.694	.923	.750	.913	.925	.583	.828	.845	.830	.929	.750	.966	.984

City of Big Bear Lake
 N/S: Stanfield Cutoff/Starvation Flats
 E/W: Big Bear Boulevard (SR-18)
 Weather: Clear

File Name : BBLSTBIPM
 Site Code : 05116469
 Start Date : 9/9/2016
 Page No : 2

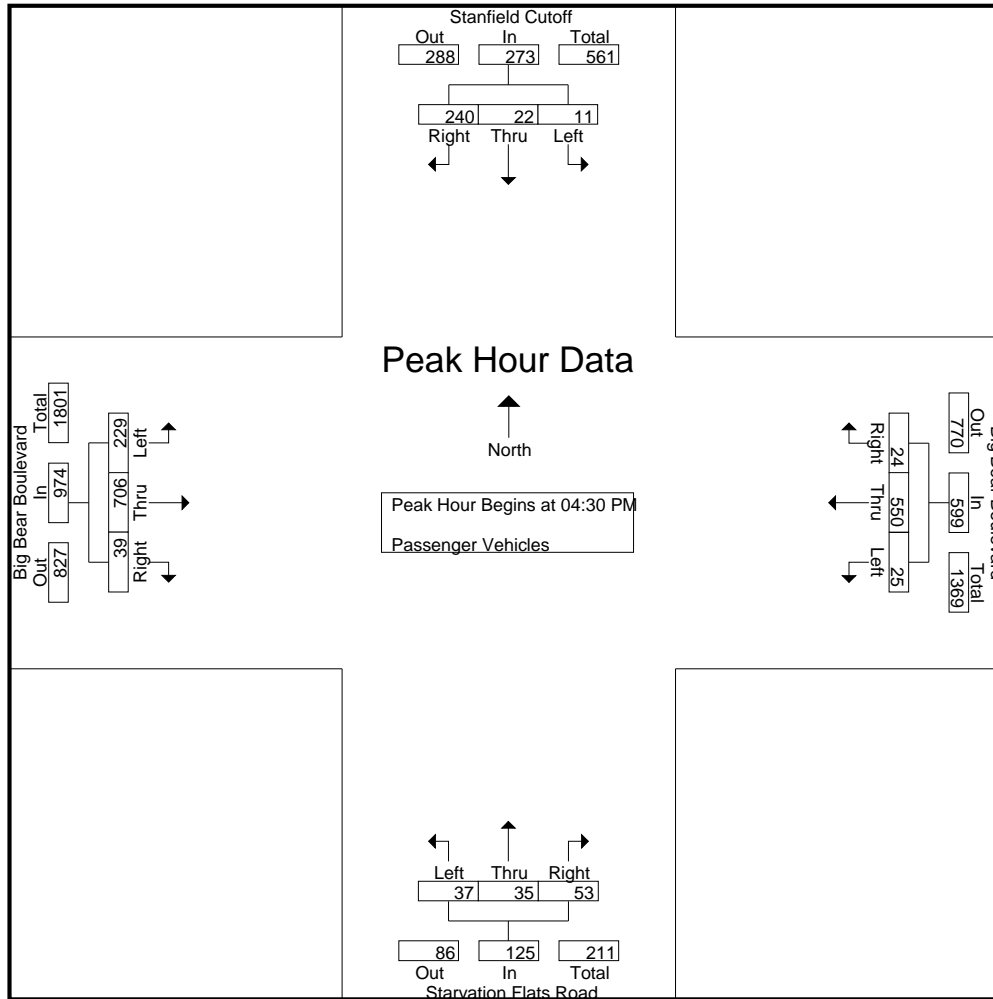

Counts Unlimited
 PO Box 1178
 Corona, CA 92878
 (951) 268-6268

City of Big Bear Lake
 N/S: Stanfield Cutoff/Starvation Flats
 E/W: Big Bear Boulevard (SR-18)
 Weather: Clear

File Name : BBLSTBIPM
 Site Code : 05116469
 Start Date : 9/9/2016
 Page No : 3

Start Time	Stanfield Cutoff Southbound				Big Bear Boulevard Westbound				Starvation Flats Road Northbound				Big Bear Boulevard Eastbound				Int. Total
	Left	Thru	Right	App. Total	Left	Thru	Right	App. Total	Left	Thru	Right	App. Total	Left	Thru	Right	App. Total	
Peak Hour Analysis From 04:30 PM to 05:15 PM - Peak 1 of 1																	
Peak Hour for Each Approach Begins at:																	
	04:30 PM				04:30 PM				04:30 PM				04:30 PM				
+0 mins.	1	5	73	79	9	149	6	164	9	4	16	29	53	168	6	227	
+15 mins.	4	8	59	71	5	138	4	147	9	9	16	34	60	178	10	248	
+30 mins.	2	5	60	67	7	135	8	150	9	15	13	37	47	190	10	247	
+45 mins.	4	4	48	56	4	128	6	138	10	7	8	25	69	170	13	252	
Total Volume	11	22	240	273	25	550	24	599	37	35	53	125	229	706	39	974	
% App. Total	4	8.1	87.9		4.2	91.8	4		29.6	28	42.4		23.5	72.5	4		
PHF	.688	.688	.822	.864	.694	.923	.750	.913	.925	.583	.828	.845	.830	.929	.750	.966	

Counts Unlimited
 PO Box 1178
 Corona, CA 92878
 (951) 268-6268

City of Big Bear Lake
 N/S: Stanfield Cutoff/Starvation Flats
 E/W: Big Bear Boulevard (SR-18)
 Weather: Clear

File Name : BBLSTBIPM
 Site Code : 05116469
 Start Date : 9/9/2016
 Page No : 1

Groups Printed- Large 2 Axle Vehicles

Start Time	Stanfield Cutoff Southbound					Big Bear Boulevard Westbound					Starvation Flats Road Northbound					Big Bear Boulevard Eastbound					Exclu. Total	Inclu. Total	Int. Total
	Left	Thru	Right	RTOR	App. Total	Left	Thru	Right	RTOR	App. Total	Left	Thru	Right	RTOR	App. Total	Left	Thru	Right	RTOR	App. Total			
04:00 PM	0	0	1	1	1	0	3	0	0	3	0	0	1	0	1	0	3	1	0	4	1	9	10
04:15 PM	0	0	3	0	3	0	2	0	0	2	0	0	0	0	0	0	3	1	0	4	0	9	9
04:30 PM	0	0	0	0	0	0	5	0	0	5	0	0	0	0	0	0	1	0	0	1	0	6	6
04:45 PM	0	0	0	0	0	0	2	0	0	2	1	0	0	0	1	0	4	0	0	4	0	7	7
Total	0	0	4	1	4	0	12	0	0	12	1	0	1	0	2	0	11	2	0	13	1	31	32
05:00 PM	0	0	1	0	1	0	1	0	0	1	0	0	1	0	1	0	3	2	1	5	1	8	9
05:15 PM	0	0	3	0	3	0	0	0	0	0	0	0	0	0	0	1	4	0	0	5	0	8	8
05:30 PM	0	0	2	0	2	0	1	0	0	1	0	0	0	1	0	0	1	0	0	1	1	4	5
05:45 PM	0	0	0	0	0	0	2	0	0	2	0	0	0	0	0	0	2	0	0	2	0	4	4
Total	0	0	6	0	6	0	4	0	0	4	0	0	1	1	1	1	10	2	1	13	2	24	26
Grand Total	0	0	10	1	10	0	16	0	0	16	1	0	2	1	3	1	21	4	1	26	3	55	58
Apprch %	0	0	100			0	100	0			33.3	0	66.7			3.8	80.8	15.4					
Total %	0	0	18.2		18.2	0	29.1	0		29.1	1.8	0	3.6		5.5	1.8	38.2	7.3		47.3	5.2	94.8	

Start Time	Stanfield Cutoff Southbound				Big Bear Boulevard Westbound				Starvation Flats Road Northbound				Big Bear Boulevard Eastbound				Int. Total
	Left	Thru	Right	App. Total	Left	Thru	Right	App. Total	Left	Thru	Right	App. Total	Left	Thru	Right	App. Total	
Peak Hour Analysis From 04:30 PM to 05:15 PM - Peak 1 of 1																	
Peak Hour for Entire Intersection Begins at 04:30 PM																	
04:30 PM	0	0	0	0	0	5	0	5	0	0	0	0	0	1	0	1	6
04:45 PM	0	0	0	0	0	2	0	2	1	0	0	1	0	4	0	4	7
05:00 PM	0	0	1	1	0	1	0	1	0	0	1	1	0	3	2	5	8
05:15 PM	0	0	3	3	0	0	0	0	0	0	0	0	1	4	0	5	8
Total Volume	0	0	4	4	0	8	0	8	1	0	1	2	1	12	2	15	29
% App. Total	0	0	100		0	100	0		50	0	50		6.7	80	13.3		
PHF	.000	.000	.333	.333	.000	.400	.000	.400	.250	.000	.250	.500	.250	.750	.250	.750	.906

City of Big Bear Lake
 N/S: Stanfield Cutoff/Starvation Flats
 E/W: Big Bear Boulevard (SR-18)
 Weather: Clear

File Name : BBLSTBIPM
 Site Code : 05116469
 Start Date : 9/9/2016
 Page No : 2

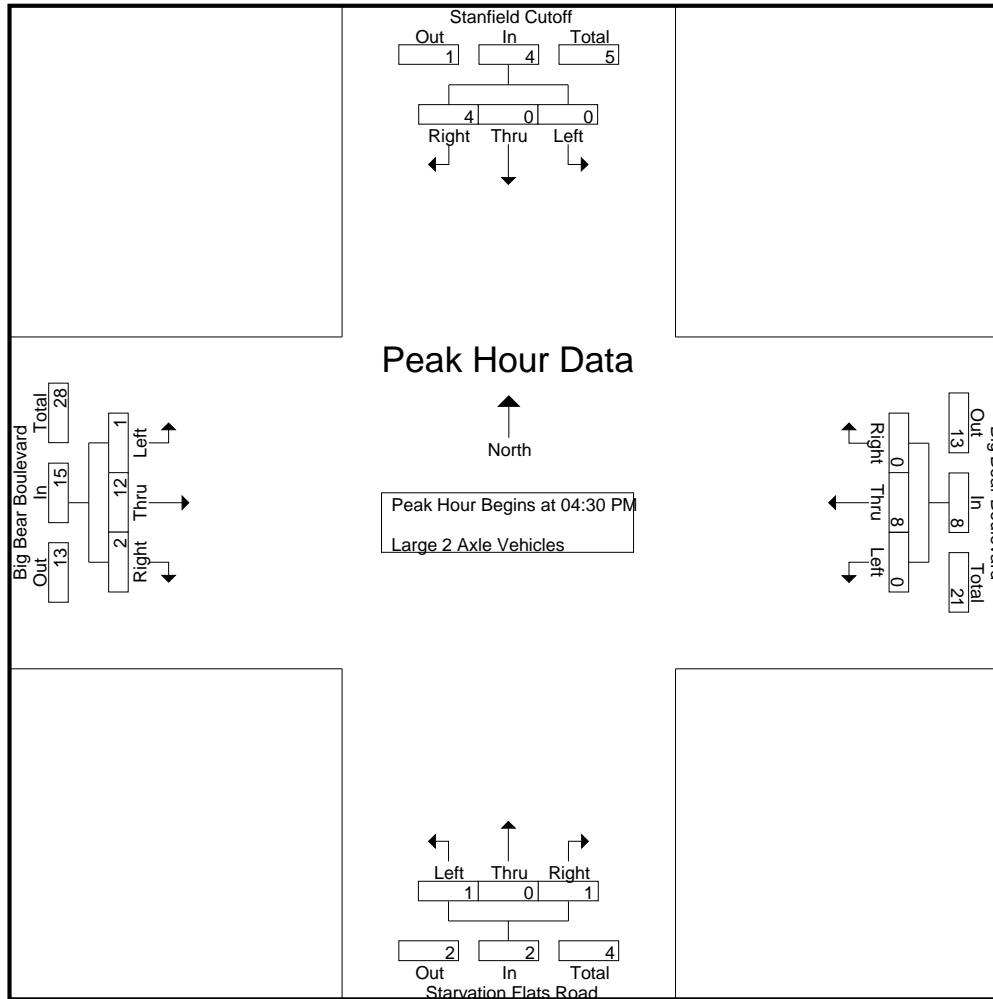

Counts Unlimited
 PO Box 1178
 Corona, CA 92878
 (951) 268-6268

City of Big Bear Lake
 N/S: Stanfield Cutoff/Starvation Flats
 E/W: Big Bear Boulevard (SR-18)
 Weather: Clear

File Name : BBLSTBIPM
 Site Code : 05116469
 Start Date : 9/9/2016
 Page No : 3

Start Time	Stanfield Cutoff Southbound				Big Bear Boulevard Westbound				Starvation Flats Road Northbound				Big Bear Boulevard Eastbound				Int. Total
	Left	Thru	Right	App. Total	Left	Thru	Right	App. Total	Left	Thru	Right	App. Total	Left	Thru	Right	App. Total	
Peak Hour Analysis From 04:30 PM to 05:15 PM - Peak 1 of 1																	
Peak Hour for Each Approach Begins at:																	
	04:30 PM				04:30 PM				04:30 PM				04:30 PM				
+0 mins.	0	0	0	0	0	5	0	5	0	0	0	0	0	1	0	1	
+15 mins.	0	0	0	0	0	2	0	2	1	0	0	1	0	4	0	4	
+30 mins.	0	0	1	1	0	1	0	1	0	0	1	1	0	3	2	5	
+45 mins.	0	0	3	3	0	0	0	0	0	0	0	0	1	4	0	5	
Total Volume	0	0	4	4	0	8	0	8	1	0	1	2	1	12	2	15	
% App. Total	0	0	100		0	100	0		50	0	50		6.7	80	13.3		
PHF	.000	.000	.333	.333	.000	.400	.000	.400	.250	.000	.250	.500	.250	.750	.250	.750	

City of Big Bear Lake
 N/S: Stanfield Cutoff/Starvation Flats
 E/W: Big Bear Boulevard (SR-18)
 Weather: Clear

File Name : BBLSTBIPM
 Site Code : 05116469
 Start Date : 9/9/2016
 Page No : 1

Groups Printed- 3 Axle Vehicles

Start Time	Stanfield Cutoff Southbound					Big Bear Boulevard Westbound					Starvation Flats Road Northbound					Big Bear Boulevard Eastbound					Exclu. Total	Inclu. Total	Int. Total
	Left	Thru	Right	RTOR	App. Total	Left	Thru	Right	RTOR	App. Total	Left	Thru	Right	RTOR	App. Total	Left	Thru	Right	RTOR	App. Total			
04:00 PM	0	0	1	1	1	0	1	0	0	1	0	1	1	0	2	0	0	0	0	0	1	4	5
04:15 PM	0	0	1	0	1	0	0	0	0	0	0	1	0	0	1	0	1	0	0	1	0	3	3
04:30 PM	0	0	0	0	0	0	0	0	0	0	0	0	0	0	0	0	2	0	0	2	0	2	2
04:45 PM	0	0	0	0	0	0	1	0	0	1	0	0	0	0	0	0	0	0	0	0	0	1	1
Total	0	0	2	1	2	0	2	0	0	2	0	2	1	0	3	0	3	0	0	3	1	10	11
05:00 PM	0	0	0	0	0	0	0	0	0	0	0	0	0	0	0	1	1	0	0	2	0	2	2
05:15 PM	0	0	3	3	3	0	0	0	0	0	0	0	0	0	0	0	0	0	0	0	3	3	6
05:30 PM	0	0	1	1	1	0	0	0	0	0	1	0	0	0	1	0	0	0	0	0	1	2	3
05:45 PM	0	0	1	0	1	0	1	0	0	1	0	0	0	0	0	0	0	0	0	0	0	2	2
Total	0	0	5	4	5	0	1	0	0	1	1	0	0	0	1	1	1	0	0	2	4	9	13
Grand Total	0	0	7	5	7	0	3	0	0	3	1	2	1	0	4	1	4	0	0	5	5	19	24
Apprch %	0	0	100			0	100	0			25	50	25			20	80	0					
Total %	0	0	36.8		36.8	0	15.8	0		15.8	5.3	10.5	5.3		21.1	5.3	21.1	0		26.3	20.8	79.2	

Start Time	Stanfield Cutoff Southbound				Big Bear Boulevard Westbound				Starvation Flats Road Northbound				Big Bear Boulevard Eastbound				Int. Total
	Left	Thru	Right	App. Total	Left	Thru	Right	App. Total	Left	Thru	Right	App. Total	Left	Thru	Right	App. Total	
Peak Hour Analysis From 04:30 PM to 05:15 PM - Peak 1 of 1																	
Peak Hour for Entire Intersection Begins at 04:30 PM																	
04:30 PM	0	0	0	0	0	0	0	0	0	0	0	0	0	2	0	2	2
04:45 PM	0	0	0	0	0	1	0	1	0	0	0	0	0	0	0	0	1
05:00 PM	0	0	0	0	0	0	0	0	0	0	0	0	1	1	0	2	2
05:15 PM	0	0	3	3	0	0	0	0	0	0	0	0	0	0	0	0	3
Total Volume	0	0	3	3	0	1	0	1	0	0	0	0	1	3	0	4	8
% App. Total	0	0	100		0	100	0		0	0	0		25	75	0		
PHF	.000	.000	.250	.250	.000	.250	.000	.250	.000	.000	.000	.000	.250	.375	.000	.500	.667

City of Big Bear Lake
 N/S: Stanfield Cutoff/Starvation Flats
 E/W: Big Bear Boulevard (SR-18)
 Weather: Clear

File Name : BBLSTBIPM
 Site Code : 05116469
 Start Date : 9/9/2016
 Page No : 2

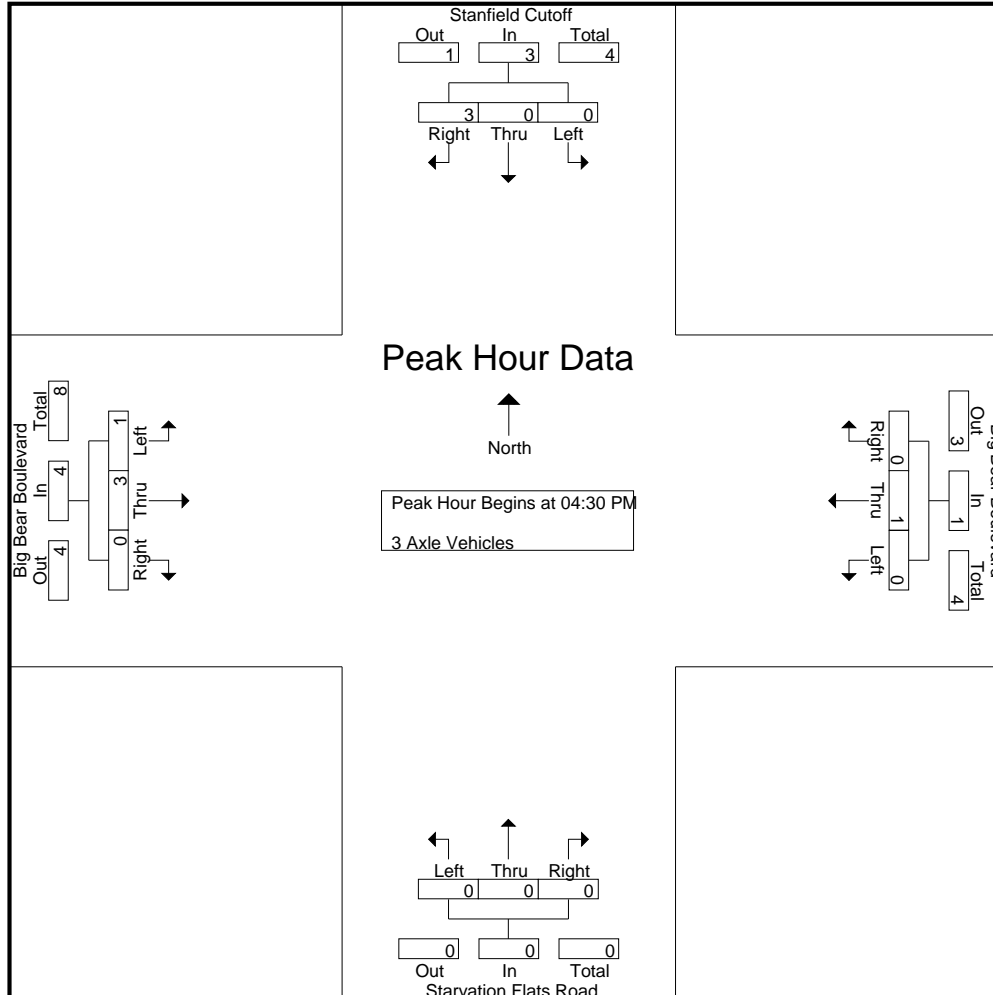

Counts Unlimited
 PO Box 1178
 Corona, CA 92878
 (951) 268-6268

City of Big Bear Lake
 N/S: Stanfield Cutoff/Starvation Flats
 E/W: Big Bear Boulevard (SR-18)
 Weather: Clear

File Name : BBLSTBIPM
 Site Code : 05116469
 Start Date : 9/9/2016
 Page No : 3

Start Time	Stanfield Cutoff Southbound				Big Bear Boulevard Westbound				Starvation Flats Road Northbound				Big Bear Boulevard Eastbound				Int. Total
	Left	Thru	Right	App. Total	Left	Thru	Right	App. Total	Left	Thru	Right	App. Total	Left	Thru	Right	App. Total	
Peak Hour Analysis From 04:30 PM to 05:15 PM - Peak 1 of 1																	
Peak Hour for Each Approach Begins at:																	
	04:30 PM				04:30 PM				04:30 PM				04:30 PM				
+0 mins.	0	0	0	0	0	0	0	0	0	0	0	0	0	2	0	2	
+15 mins.	0	0	0	0	0	1	0	1	0	0	0	0	0	0	0	0	
+30 mins.	0	0	0	0	0	0	0	0	0	0	0	0	1	1	0	2	
+45 mins.	0	0	3	3	0	0	0	0	0	0	0	0	0	0	0	0	
Total Volume	0	0	3	3	0	1	0	1	0	0	0	0	1	3	0	4	
% App. Total	0	0	100		0	100	0		0	0	0		25	75	0		
PHF	.000	.000	.250	.250	.000	.250	.000	.250	.000	.000	.000	.000	.250	.375	.000	.500	

City of Big Bear Lake
 N/S: Stanfield Cutoff/Starvation Flats
 E/W: Big Bear Boulevard (SR-18)
 Weather: Clear

File Name : BBLSTBIPM
 Site Code : 05116469
 Start Date : 9/9/2016
 Page No : 1

Groups Printed- 4+ Axle Trucks

Start Time	Stanfield Cutoff Southbound					Big Bear Boulevard Westbound					Starvation Flats Road Northbound					Big Bear Boulevard Eastbound					Exclu. Total	Inclu. Total	Int. Total
	Left	Thru	Right	RTOR	App. Total	Left	Thru	Right	RTOR	App. Total	Left	Thru	Right	RTOR	App. Total	Left	Thru	Right	RTOR	App. Total			
04:00 PM	0	0	0	0	0	0	0	0	0	0	0	0	0	1	0	0	0	0	0	0	1	0	1
04:15 PM	0	0	0	1	0	0	0	0	0	0	0	0	0	0	0	0	2	0	0	2	1	2	3
04:30 PM	0	0	0	0	0	0	0	0	0	0	0	0	0	0	0	0	0	0	0	0	0	0	0
04:45 PM	0	0	0	0	0	0	2	0	0	2	0	0	0	0	0	0	0	0	0	0	0	2	2
Total	0	0	0	1	0	0	2	0	0	2	0	0	0	1	0	0	2	0	0	2	2	4	6
05:00 PM	0	0	0	0	0	0	0	0	0	0	0	0	0	0	0	1	0	0	0	1	0	1	1
05:15 PM	0	0	0	0	0	0	0	0	0	0	0	0	0	0	0	0	0	0	0	0	0	0	0
05:30 PM	0	0	0	0	0	0	0	0	0	0	0	0	0	0	0	0	0	0	0	0	0	0	0
05:45 PM	0	0	0	1	0	0	0	0	0	0	0	0	0	0	0	0	0	0	0	0	1	0	1
Total	0	0	0	1	0	0	0	0	0	0	0	0	0	0	0	1	0	0	0	1	1	1	2
Grand Total	0	0	0	2	0	0	2	0	0	2	0	0	0	1	0	1	2	0	0	3	3	5	8
Apprch %	0	0	0			0	100	0			0	0	0			33.3	66.7	0					
Total %	0	0	0			0	40	0		40	0	0	0		0	20	40	0		60	37.5	62.5	

Start Time	Stanfield Cutoff Southbound				Big Bear Boulevard Westbound				Starvation Flats Road Northbound				Big Bear Boulevard Eastbound				Int. Total
	Left	Thru	Right	App. Total	Left	Thru	Right	App. Total	Left	Thru	Right	App. Total	Left	Thru	Right	App. Total	
Peak Hour Analysis From 04:30 PM to 05:15 PM - Peak 1 of 1																	
Peak Hour for Entire Intersection Begins at 04:30 PM																	
04:30 PM	0	0	0	0	0	0	0	0	0	0	0	0	0	0	0	0	0
04:45 PM	0	0	0	0	0	2	0	2	0	0	0	0	0	0	0	0	2
05:00 PM	0	0	0	0	0	0	0	0	0	0	0	0	1	0	0	1	1
05:15 PM	0	0	0	0	0	0	0	0	0	0	0	0	0	0	0	0	0
Total Volume	0	0	0	0	0	2	0	2	0	0	0	0	1	0	0	1	3
% App. Total	0	0	0	0	0	100	0		0	0	0		100	0	0		
PHF	.000	.000	.000	.000	.000	.250	.000	.250	.000	.000	.000	.000	.250	.000	.000	.250	.375

City of Big Bear Lake
 N/S: Stanfield Cutoff/Starvation Flats
 E/W: Big Bear Boulevard (SR-18)
 Weather: Clear

File Name : BBLSTBIPM
 Site Code : 05116469
 Start Date : 9/9/2016
 Page No : 2

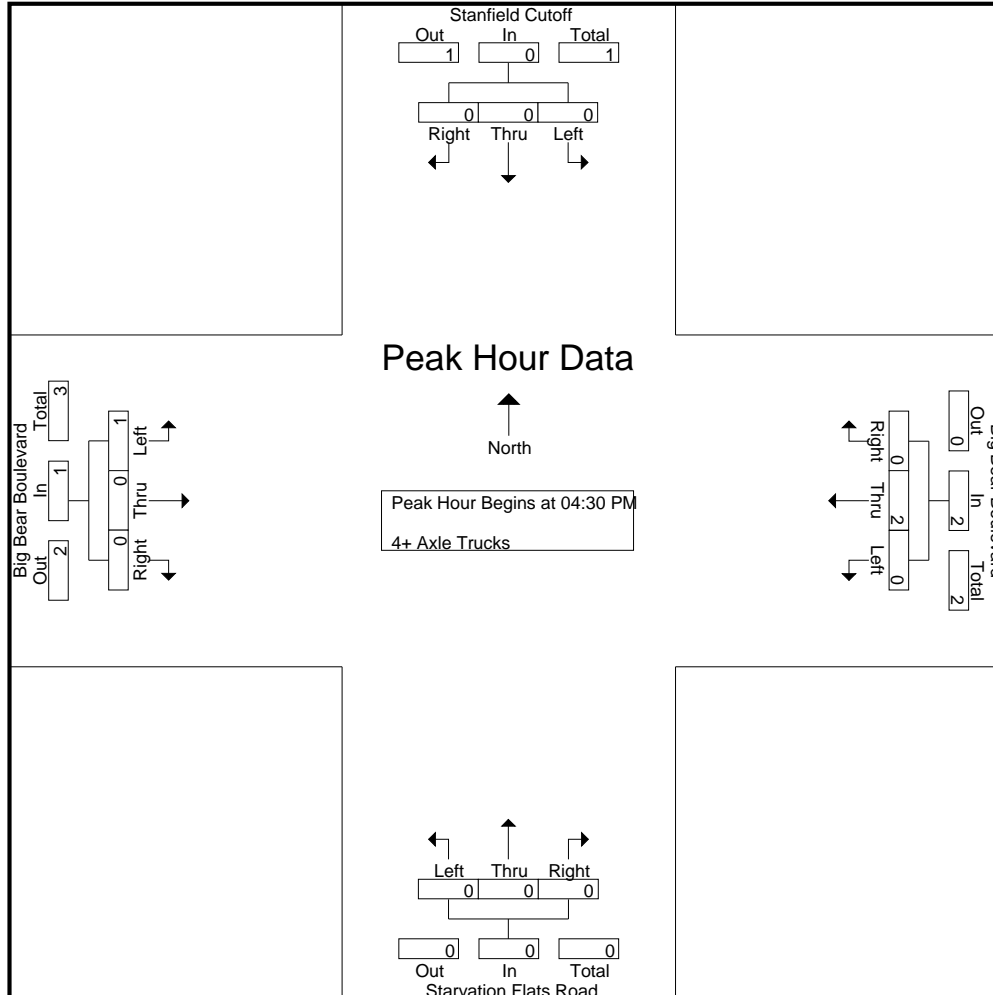

Counts Unlimited
 PO Box 1178
 Corona, CA 92878
 (951) 268-6268

City of Big Bear Lake
 N/S: Stanfield Cutoff/Starvation Flats
 E/W: Big Bear Boulevard (SR-18)
 Weather: Clear

File Name : BBLSTBIPM
 Site Code : 05116469
 Start Date : 9/9/2016
 Page No : 3

Start Time	Stanfield Cutoff Southbound				Big Bear Boulevard Westbound				Starvation Flats Road Northbound				Big Bear Boulevard Eastbound				Int. Total
	Left	Thru	Right	App. Total	Left	Thru	Right	App. Total	Left	Thru	Right	App. Total	Left	Thru	Right	App. Total	

Peak Hour Analysis From 04:30 PM to 05:15 PM - Peak 1 of 1

Peak Hour for Each Approach Begins at:

	04:30 PM				04:30 PM				04:30 PM				04:30 PM			
+0 mins.	0	0	0	0	0	0	0	0	0	0	0	0	0	0	0	0
+15 mins.	0	0	0	0	0	2	0	2	0	0	0	0	0	0	0	0
+30 mins.	0	0	0	0	0	0	0	0	0	0	0	0	1	0	0	1
+45 mins.	0	0	0	0	0	0	0	0	0	0	0	0	0	0	0	0
Total Volume	0	0	0	0	0	2	0	2	0	0	0	0	1	0	0	1
% App. Total	0	0	0	0	0	100	0		0	0	0		100	0	0	
PHF	.000	.000	.000	.000	.000	.250	.000	.250	.000	.000	.000	.000	.250	.000	.000	.250

City of Big Bear Lake
 N/S: Stanfield Cutoff/Starvation Flats
 E/W: Big Bear Boulevard (SR-18)
 Weather: Clear

File Name : BBLSTBISUN
 Site Code : 05116469
 Start Date : 9/11/2016
 Page No : 1

Groups Printed- Passenger Vehicles - Large 2 Axle Vehicles - 3 Axle Vehicles - 4+ Axle Trucks

Start Time	Stanfield Cutoff Southbound					Big Bear Boulevard Westbound					Starvation Flats Road Northbound					Big Bear Boulevard Eastbound					Exclu. Total	Inclu. Total	Int. Total
	Left	Thru	Right	RTOR	App. Total	Left	Thru	Right	RTOR	App. Total	Left	Thru	Right	RTOR	App. Total	Left	Thru	Right	RTOR	App. Total			
12:00 PM	3	3	66	1	72	7	112	2	0	121	12	16	9	0	37	53	150	11	0	214	1	444	445
12:15 PM	9	8	108	0	125	4	137	3	0	144	17	9	11	0	37	62	174	13	0	249	0	555	555
12:30 PM	9	7	79	1	95	7	137	7	0	151	6	10	10	0	26	65	168	6	0	239	1	511	512
12:45 PM	3	5	54	0	62	5	150	9	0	164	10	7	10	0	27	81	154	6	0	241	0	494	494
Total	24	23	307	2	354	23	536	21	0	580	45	42	40	0	127	261	646	36	0	943	2	2004	2006
01:00 PM	3	9	56	0	68	11	139	6	0	156	10	6	14	0	30	70	185	5	0	260	0	514	514
01:15 PM	2	5	74	0	81	6	99	5	0	110	7	10	6	0	23	48	168	6	0	222	0	436	436
01:30 PM	9	9	49	0	67	4	117	5	0	126	6	7	9	0	22	65	140	3	0	208	0	423	423
01:45 PM	5	4	59	0	68	5	130	3	0	138	12	9	9	0	30	59	172	2	0	233	0	469	469
Total	19	27	238	0	284	26	485	19	0	530	35	32	38	0	105	242	665	16	0	923	0	1842	1842
Grand Total	43	50	545	2	638	49	1021	40	0	1110	80	74	78	0	232	503	1311	52	0	1866	2	3846	3848
Apprch %	6.7	7.8	85.4			4.4	92	3.6			34.5	31.9	33.6			27	70.3	2.8					
Total %	1.1	1.3	14.2		16.6	1.3	26.5	1		28.9	2.1	1.9	2		6	13.1	34.1	1.4		48.5	0.1	99.9	
Passenger Vehicles	39	49	540		628	49	1015	39		1103	80	74	78		232	502	1303	52		1857	0	0	3820
% Passenger Vehicles	90.7	98	99.1	0	98.1	100	99.4	97.5	0	99.4	100	100	100	0	100	99.8	99.4	100	0	99.5	0	0	99.3
Large 2 Axle Vehicles	4	0	3		7	0	6	1		7	0	0	0		0	1	8	0		9	0	0	23
% Large 2 Axle Vehicles	9.3	0	0.6	0	1.1	0	0.6	2.5	0	0.6	0	0	0	0	0	0.2	0.6	0	0	0.5	0	0	0.6
3 Axle Vehicles	0	0	2		4	0	0	0		0	0	0	0		0	0	0	0		0	0	0	4
% 3 Axle Vehicles	0	0	0.4	100	0.6	0	0	0	0	0	0	0	0	0	0	0	0	0	0	0	0	0	0.1
4+ Axle Trucks	0	1	0		1	0	0	0		0	0	0	0		0	0	0	0		0	0	0	1
% 4+ Axle Trucks	0	2	0	0	0.2	0	0	0	0	0	0	0	0	0	0	0	0	0	0	0	0	0	0

Start Time	Stanfield Cutoff Southbound				Big Bear Boulevard Westbound				Starvation Flats Road Northbound				Big Bear Boulevard Eastbound				Int. Total
	Left	Thru	Right	App. Total	Left	Thru	Right	App. Total	Left	Thru	Right	App. Total	Left	Thru	Right	App. Total	
Peak Hour Analysis From 12:00 PM to 01:45 PM - Peak 1 of 1																	
Peak Hour for Entire Intersection Begins at 12:15 PM																	
12:15 PM	9	8	108	125	4	137	3	144	17	9	11	37	62	174	13	249	555
12:30 PM	9	7	79	95	7	137	7	151	6	10	10	26	65	168	6	239	511
12:45 PM	3	5	54	62	5	150	9	164	10	7	10	27	81	154	6	241	494
01:00 PM	3	9	56	68	11	139	6	156	10	6	14	30	70	185	5	260	514
Total Volume	24	29	297	350	27	563	25	615	43	32	45	120	278	681	30	989	2074
% App. Total	6.9	8.3	84.9		4.4	91.5	4.1		35.8	26.7	37.5		28.1	68.9	3		
PHF	.667	.806	.688	.700	.614	.938	.694	.938	.632	.800	.804	.811	.858	.920	.577	.951	.934

City of Big Bear Lake
 N/S: Stanfield Cutoff/Starvation Flats
 E/W: Big Bear Boulevard (SR-18)
 Weather: Clear

File Name : BBLSTBISUN
 Site Code : 05116469
 Start Date : 9/11/2016
 Page No : 2

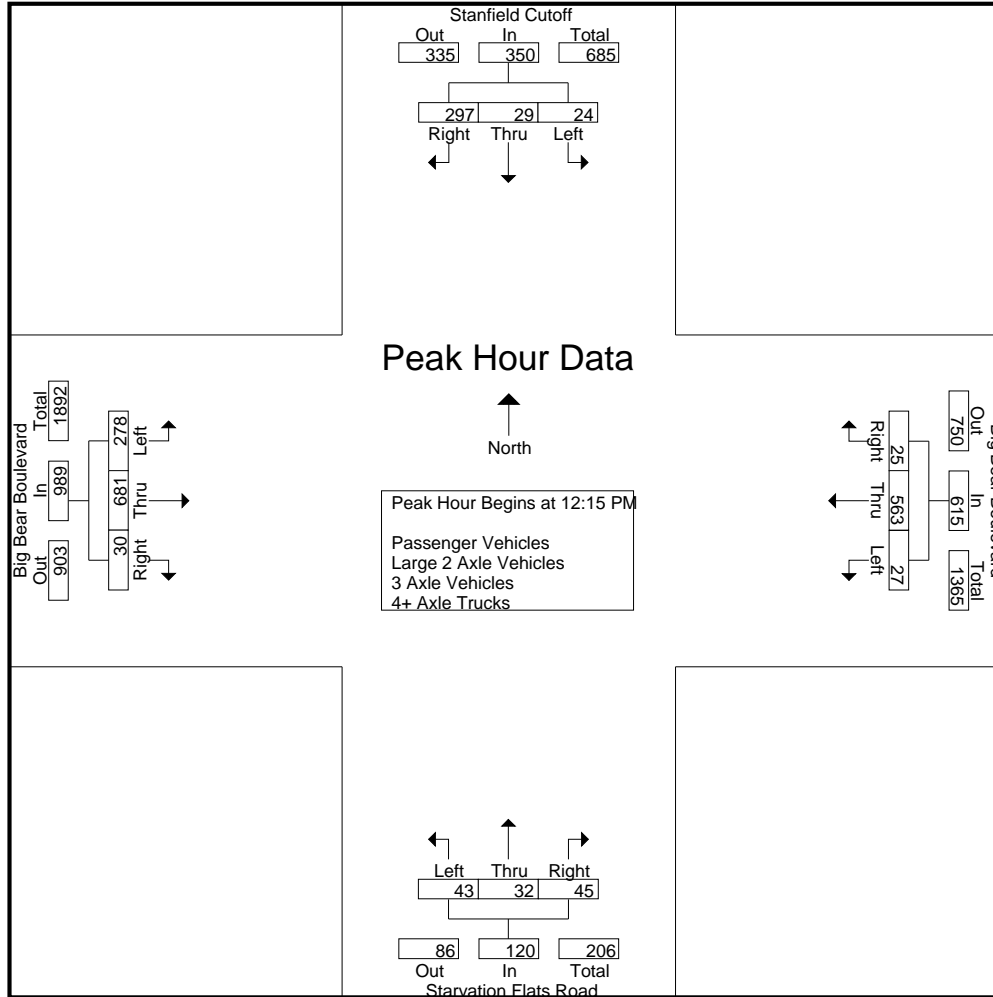

Counts Unlimited
 PO Box 1178
 Corona, CA 92878
 (951) 268-6268

City of Big Bear Lake
 N/S: Stanfield Cutoff/Starvation Flats
 E/W: Big Bear Boulevard (SR-18)
 Weather: Clear

File Name : BBLSTBISUN
 Site Code : 05116469
 Start Date : 9/11/2016
 Page No : 3

Start Time	Stanfield Cutoff Southbound				Big Bear Boulevard Westbound				Starvation Flats Road Northbound				Big Bear Boulevard Eastbound				Int. Total
	Left	Thru	Right	App. Total	Left	Thru	Right	App. Total	Left	Thru	Right	App. Total	Left	Thru	Right	App. Total	
Peak Hour Analysis From 12:00 PM to 01:45 PM - Peak 1 of 1																	
Peak Hour for Each Approach Begins at:																	
	12:00 PM				12:15 PM				12:00 PM				12:15 PM				
+0 mins.	3	3	66	72	4	137	3	144	12	16	9	37	62	174	13	249	
+15 mins.	9	8	108	125	7	137	7	151	17	9	11	37	65	168	6	239	
+30 mins.	9	7	79	95	5	150	9	164	6	10	10	26	81	154	6	241	
+45 mins.	3	5	54	62	11	139	6	156	10	7	10	27	70	185	5	260	
Total Volume	24	23	307	354	27	563	25	615	45	42	40	127	278	681	30	989	
% App. Total	6.8	6.5	86.7		4.4	91.5	4.1		35.4	33.1	31.5		28.1	68.9	3		
PHF	.667	.719	.711	.708	.614	.938	.694	.938	.662	.656	.909	.858	.858	.920	.577	.951	

Counts Unlimited
 PO Box 1178
 Corona, CA 92878
 (951) 268-6268

City of Big Bear Lake
 N/S: Stanfield Cutoff/Starvation Flats
 E/W: Big Bear Boulevard (SR-18)
 Weather: Clear

File Name : BBLSTBISUN
 Site Code : 05116469
 Start Date : 9/11/2016
 Page No : 1

Groups Printed- Passenger Vehicles

Start Time	Stanfield Cutoff Southbound					Big Bear Boulevard Westbound					Starvation Flats Road Northbound					Big Bear Boulevard Eastbound					Exclu. Total	Inclu. Total	Int. Total
	Left	Thru	Right	RTOR	App. Total	Left	Thru	Right	RTOR	App. Total	Left	Thru	Right	RTOR	App. Total	Left	Thru	Right	RTOR	App. Total			
12:00 PM	3	3	65	0	71	7	112	2	0	121	12	16	9	0	37	52	149	11	0	212	0	441	441
12:15 PM	6	8	106	0	120	4	137	3	0	144	17	9	11	0	37	62	173	13	0	248	0	549	549
12:30 PM	8	6	78	0	92	7	137	7	0	151	6	10	10	0	26	65	167	6	0	238	0	507	507
12:45 PM	3	5	53	0	61	5	148	9	0	162	10	7	10	0	27	81	154	6	0	241	0	491	491
Total	20	22	302	0	344	23	534	21	0	578	45	42	40	0	127	260	643	36	0	939	0	1988	1988
01:00 PM	3	9	56	0	68	11	139	5	0	155	10	6	14	0	30	70	183	5	0	258	0	511	511
01:15 PM	2	5	74	0	81	6	98	5	0	109	7	10	6	0	23	48	168	6	0	222	0	435	435
01:30 PM	9	9	49	0	67	4	115	5	0	124	6	7	9	0	22	65	140	3	0	208	0	421	421
01:45 PM	5	4	59	0	68	5	129	3	0	137	12	9	9	0	30	59	169	2	0	230	0	465	465
Total	19	27	238	0	284	26	481	18	0	525	35	32	38	0	105	242	660	16	0	918	0	1832	1832
Grand Total	39	49	540	0	628	49	1015	39	0	1103	80	74	78	0	232	502	1303	52	0	1857	0	3820	3820
Apprch %	6.2	7.8	86			4.4	92	3.5			34.5	31.9	33.6			27	70.2	2.8					
Total %	1	1.3	14.1		16.4	1.3	26.6	1		28.9	2.1	1.9	2		6.1	13.1	34.1	1.4		48.6	0	100	

Start Time	Stanfield Cutoff Southbound				Big Bear Boulevard Westbound				Starvation Flats Road Northbound				Big Bear Boulevard Eastbound				Int. Total
	Left	Thru	Right	App. Total	Left	Thru	Right	App. Total	Left	Thru	Right	App. Total	Left	Thru	Right	App. Total	
Peak Hour Analysis From 12:15 PM to 01:00 PM - Peak 1 of 1																	
Peak Hour for Entire Intersection Begins at 12:15 PM																	
12:15 PM	6	8	106	120	4	137	3	144	17	9	11	37	62	173	13	248	549
12:30 PM	8	6	78	92	7	137	7	151	6	10	10	26	65	167	6	238	507
12:45 PM	3	5	53	61	5	148	9	162	10	7	10	27	81	154	6	241	491
01:00 PM	3	9	56	68	11	139	5	155	10	6	14	30	70	183	5	258	511
Total Volume	20	28	293	341	27	561	24	612	43	32	45	120	278	677	30	985	2058
% App. Total	5.9	8.2	85.9		4.4	91.7	3.9		35.8	26.7	37.5		28.2	68.7	3		
PHF	.625	.778	.691	.710	.614	.948	.667	.944	.632	.800	.804	.811	.858	.925	.577	.954	.937

City of Big Bear Lake
 N/S: Stanfield Cutoff/Starvation Flats
 E/W: Big Bear Boulevard (SR-18)
 Weather: Clear

File Name : BBLSTBISUN
 Site Code : 05116469
 Start Date : 9/11/2016
 Page No : 2

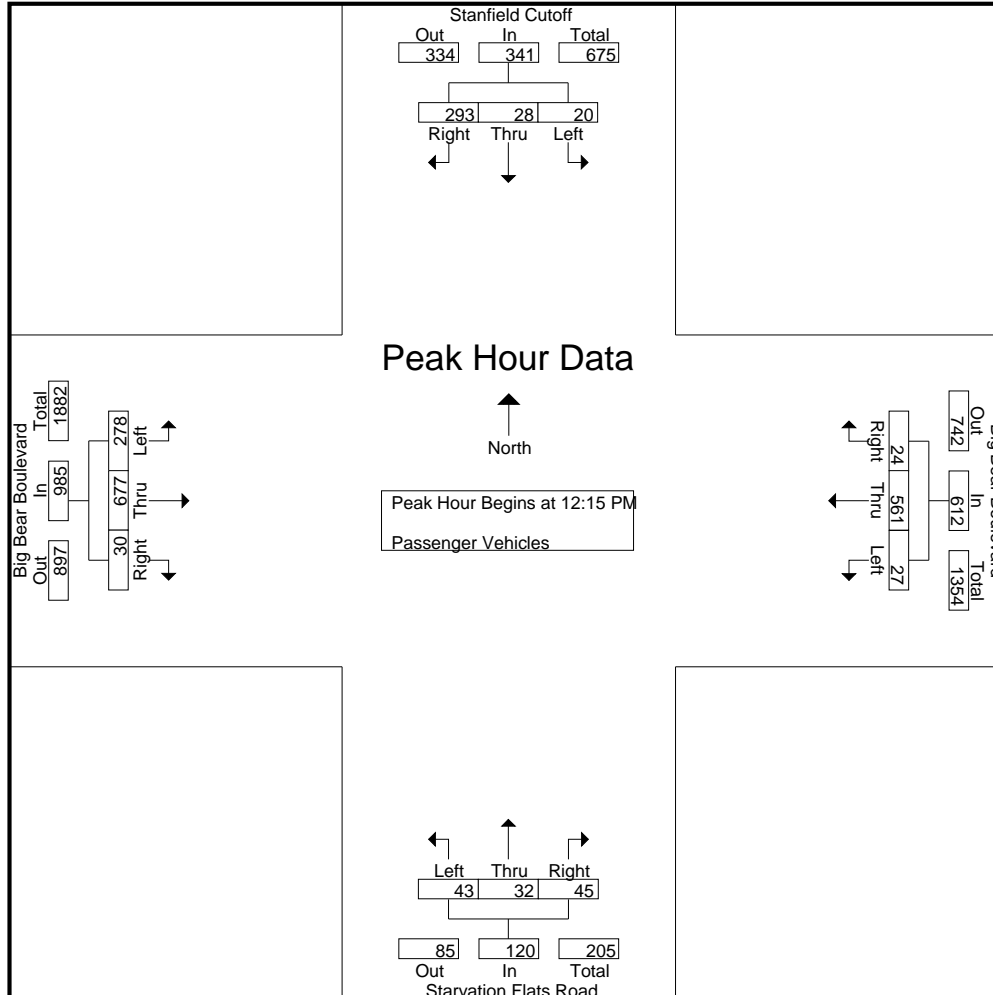

Counts Unlimited
 PO Box 1178
 Corona, CA 92878
 (951) 268-6268

City of Big Bear Lake
 N/S: Stanfield Cutoff/Starvation Flats
 E/W: Big Bear Boulevard (SR-18)
 Weather: Clear

File Name : BBLSTBISUN
 Site Code : 05116469
 Start Date : 9/11/2016
 Page No : 3

Start Time	Stanfield Cutoff Southbound				Big Bear Boulevard Westbound				Starvation Flats Road Northbound				Big Bear Boulevard Eastbound				Int. Total
	Left	Thru	Right	App. Total	Left	Thru	Right	App. Total	Left	Thru	Right	App. Total	Left	Thru	Right	App. Total	

Peak Hour Analysis From 12:15 PM to 01:00 PM - Peak 1 of 1

Peak Hour for Each Approach Begins at:

	12:15 PM				12:15 PM				12:15 PM				12:15 PM			
+0 mins.	6	8	106	120	4	137	3	144	17	9	11	37	62	173	13	248
+15 mins.	8	6	78	92	7	137	7	151	6	10	10	26	65	167	6	238
+30 mins.	3	5	53	61	5	148	9	162	10	7	10	27	81	154	6	241
+45 mins.	3	9	56	68	11	139	5	155	10	6	14	30	70	183	5	258
Total Volume	20	28	293	341	27	561	24	612	43	32	45	120	278	677	30	985
% App. Total	5.9	8.2	85.9		4.4	91.7	3.9		35.8	26.7	37.5		28.2	68.7	3	
PHF	.625	.778	.691	.710	.614	.948	.667	.944	.632	.800	.804	.811	.858	.925	.577	.954

Counts Unlimited
 PO Box 1178
 Corona, CA 92878
 (951) 268-6268

City of Big Bear Lake
 N/S: Stanfield Cutoff/Starvation Flats
 E/W: Big Bear Boulevard (SR-18)
 Weather: Clear

File Name : BBLSTBISUN
 Site Code : 05116469
 Start Date : 9/11/2016
 Page No : 1

Groups Printed- Large 2 Axle Vehicles

Start Time	Stanfield Cutoff Southbound					Big Bear Boulevard Westbound					Starvation Flats Road Northbound					Big Bear Boulevard Eastbound					Exclu. Total	Inclu. Total	Int. Total
	Left	Thru	Right	RTOR	App. Total	Left	Thru	Right	RTOR	App. Total	Left	Thru	Right	RTOR	App. Total	Left	Thru	Right	RTOR	App. Total			
12:00 PM	0	0	0	0	0	0	0	0	0	0	0	0	0	0	0	1	1	0	0	2	0	2	2
12:15 PM	3	0	2	0	5	0	0	0	0	0	0	0	0	0	0	0	1	0	0	1	0	6	6
12:30 PM	1	0	0	0	1	0	0	0	0	0	0	0	0	0	0	0	1	0	0	1	0	2	2
12:45 PM	0	0	1	0	1	0	2	0	0	2	0	0	0	0	0	0	0	0	0	0	0	3	3
Total	4	0	3	0	7	0	2	0	0	2	0	0	0	0	0	1	3	0	0	4	0	13	13
01:00 PM	0	0	0	0	0	0	0	1	0	1	0	0	0	0	0	0	2	0	0	2	0	3	3
01:15 PM	0	0	0	0	0	0	1	0	0	1	0	0	0	0	0	0	0	0	0	0	0	1	1
01:30 PM	0	0	0	0	0	0	2	0	0	2	0	0	0	0	0	0	0	0	0	0	0	2	2
01:45 PM	0	0	0	0	0	0	1	0	0	1	0	0	0	0	0	0	3	0	0	3	0	4	4
Total	0	0	0	0	0	0	4	1	0	5	0	0	0	0	0	0	5	0	0	5	0	10	10
Grand Total	4	0	3	0	7	0	6	1	0	7	0	0	0	0	0	1	8	0	0	9	0	23	23
Apprch %	57.1	0	42.9			0	85.7	14.3			0	0	0			11.1	88.9	0					
Total %	17.4	0	13		30.4	0	26.1	4.3		30.4	0	0	0		0	4.3	34.8	0		39.1	0	100	

Start Time	Stanfield Cutoff Southbound				Big Bear Boulevard Westbound				Starvation Flats Road Northbound				Big Bear Boulevard Eastbound				Int. Total
	Left	Thru	Right	App. Total	Left	Thru	Right	App. Total	Left	Thru	Right	App. Total	Left	Thru	Right	App. Total	
Peak Hour Analysis From 12:15 PM to 01:00 PM - Peak 1 of 1																	
Peak Hour for Entire Intersection Begins at 12:15 PM																	
12:15 PM	3	0	2	5	0	0	0	0	0	0	0	0	0	1	0	1	6
12:30 PM	1	0	0	1	0	0	0	0	0	0	0	0	0	1	0	1	2
12:45 PM	0	0	1	1	0	2	0	2	0	0	0	0	0	0	0	0	3
01:00 PM	0	0	0	0	0	0	1	1	0	0	0	0	0	2	0	2	3
Total Volume	4	0	3	7	0	2	1	3	0	0	0	0	0	4	0	4	14
% App. Total	57.1	0	42.9		0	66.7	33.3		0	0	0		0	100	0		
PHF	.333	.000	.375	.350	.000	.250	.250	.375	.000	.000	.000	.000	.000	.500	.000	.500	.583

City of Big Bear Lake
 N/S: Stanfield Cutoff/Starvation Flats
 E/W: Big Bear Boulevard (SR-18)
 Weather: Clear

File Name : BBLSTBISUN
 Site Code : 05116469
 Start Date : 9/11/2016
 Page No : 2

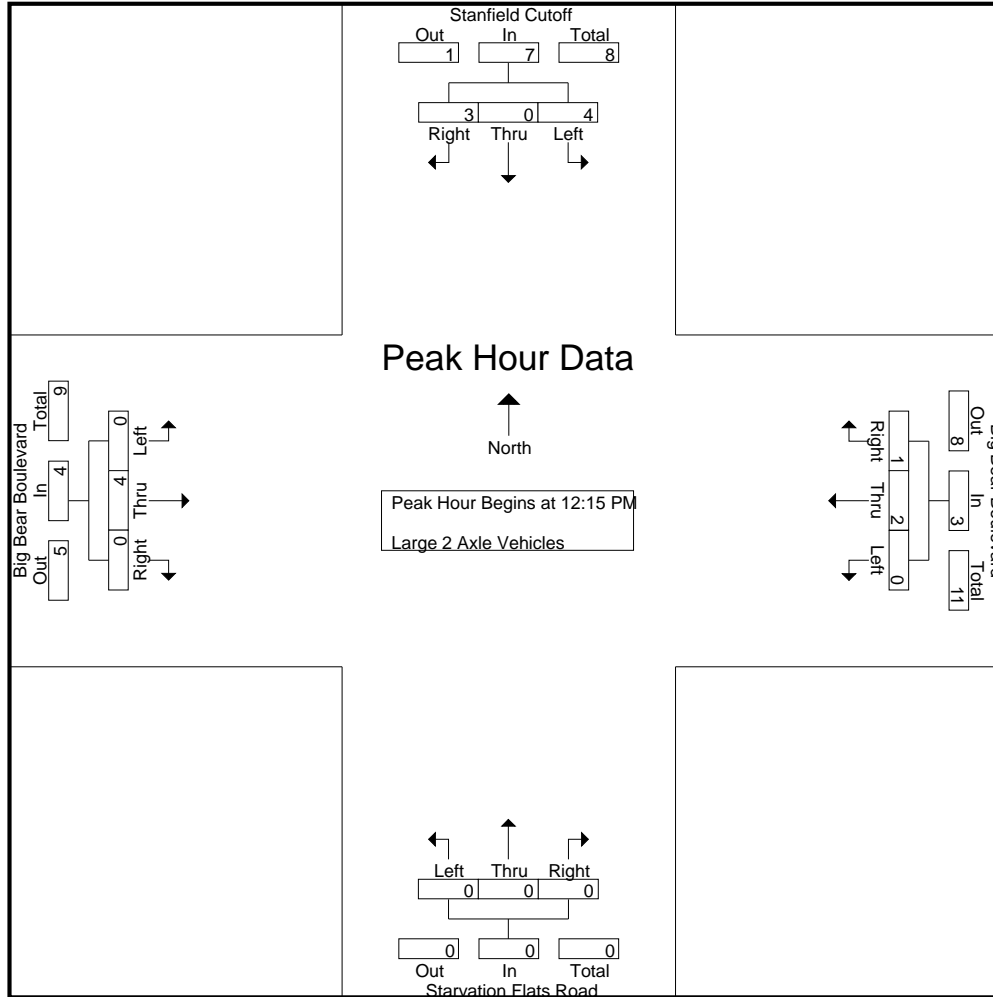

Counts Unlimited
 PO Box 1178
 Corona, CA 92878
 (951) 268-6268

City of Big Bear Lake
 N/S: Stanfield Cutoff/Starvation Flats
 E/W: Big Bear Boulevard (SR-18)
 Weather: Clear

File Name : BBLSTBISUN
 Site Code : 05116469
 Start Date : 9/11/2016
 Page No : 3

Start Time	Stanfield Cutoff Southbound				Big Bear Boulevard Westbound				Starvation Flats Road Northbound				Big Bear Boulevard Eastbound				Int. Total
	Left	Thru	Right	App. Total	Left	Thru	Right	App. Total	Left	Thru	Right	App. Total	Left	Thru	Right	App. Total	

Peak Hour Analysis From 12:15 PM to 01:00 PM - Peak 1 of 1

Peak Hour for Each Approach Begins at:

	12:15 PM				12:15 PM				12:15 PM				12:15 PM			
+0 mins.	3	0	2	5	0	0	0	0	0	0	0	0	0	1	0	1
+15 mins.	1	0	0	1	0	0	0	0	0	0	0	0	0	1	0	1
+30 mins.	0	0	1	1	0	2	0	2	0	0	0	0	0	0	0	0
+45 mins.	0	0	0	0	0	0	1	1	0	0	0	0	0	2	0	2
Total Volume	4	0	3	7	0	2	1	3	0	0	0	0	0	4	0	4
% App. Total	57.1	0	42.9		0	66.7	33.3		0	0	0		0	100	0	
PHF	.333	.000	.375	.350	.000	.250	.250	.375	.000	.000	.000	.000	.000	.500	.000	.500

Counts Unlimited
 PO Box 1178
 Corona, CA 92878
 (951) 268-6268

City of Big Bear Lake
 N/S: Stanfield Cutoff/Starvation Flats
 E/W: Big Bear Boulevard (SR-18)
 Weather: Clear

File Name : BBLSTBISUN
 Site Code : 05116469
 Start Date : 9/11/2016
 Page No : 1

Groups Printed- 3 Axle Vehicles

Start Time	Stanfield Cutoff Southbound					Big Bear Boulevard Westbound					Starvation Flats Road Northbound					Big Bear Boulevard Eastbound					Exclu. Total	Inclu. Total	Int. Total
	Left	Thru	Right	RTOR	App. Total	Left	Thru	Right	RTOR	App. Total	Left	Thru	Right	RTOR	App. Total	Left	Thru	Right	RTOR	App. Total			
12:00 PM	0	0	1	1	1	0	0	0	0	0	0	0	0	0	0	0	0	0	0	0	1	1	2
12:15 PM	0	0	0	0	0	0	0	0	0	0	0	0	0	0	0	0	0	0	0	0	0	0	0
12:30 PM	0	0	1	1	1	0	0	0	0	0	0	0	0	0	0	0	0	0	0	0	1	1	2
12:45 PM	0	0	0	0	0	0	0	0	0	0	0	0	0	0	0	0	0	0	0	0	0	0	0
Total	0	0	2	2	2	0	0	0	0	0	0	0	0	0	0	0	0	0	0	0	2	2	4
01:00 PM	0	0	0	0	0	0	0	0	0	0	0	0	0	0	0	0	0	0	0	0	0	0	0
01:15 PM	0	0	0	0	0	0	0	0	0	0	0	0	0	0	0	0	0	0	0	0	0	0	0
01:30 PM	0	0	0	0	0	0	0	0	0	0	0	0	0	0	0	0	0	0	0	0	0	0	0
01:45 PM	0	0	0	0	0	0	0	0	0	0	0	0	0	0	0	0	0	0	0	0	0	0	0
Total	0	0	0	0	0	0	0	0	0	0	0	0	0	0	0	0	0	0	0	0	0	0	0
Grand Total	0	0	2	2	2	0	0	0	0	0	0	0	0	0	0	0	0	0	0	0	2	2	4
Apprch %	0	0	100			0	0	0			0	0	0			0	0	0					
Total %	0	0	100		100	0	0	0		0	0	0	0		0	0	0	0		0	50	50	

Start Time	Stanfield Cutoff Southbound				Big Bear Boulevard Westbound				Starvation Flats Road Northbound				Big Bear Boulevard Eastbound				Int. Total
	Left	Thru	Right	App. Total	Left	Thru	Right	App. Total	Left	Thru	Right	App. Total	Left	Thru	Right	App. Total	
Peak Hour Analysis From 12:15 PM to 01:00 PM - Peak 1 of 1																	
Peak Hour for Entire Intersection Begins at 12:15 PM																	
12:15 PM	0	0	0	0	0	0	0	0	0	0	0	0	0	0	0	0	0
12:30 PM	0	0	1	1	0	0	0	0	0	0	0	0	0	0	0	0	1
12:45 PM	0	0	0	0	0	0	0	0	0	0	0	0	0	0	0	0	0
01:00 PM	0	0	0	0	0	0	0	0	0	0	0	0	0	0	0	0	0
Total Volume	0	0	1	1	0	0	0	0	0	0	0	0	0	0	0	0	1
% App. Total	0	0	100		0	0	0		0	0	0		0	0	0		
PHF	.000	.000	.250	.250	.000	.000	.000	.000	.000	.000	.000	.000	.000	.000	.000	.000	.250

City of Big Bear Lake
N/S: Stanfield Cutoff/Starvation Flats
E/W: Big Bear Boulevard (SR-18)
Weather: Clear

File Name : BBLSTBISUN
Site Code : 05116469
Start Date : 9/11/2016
Page No : 2

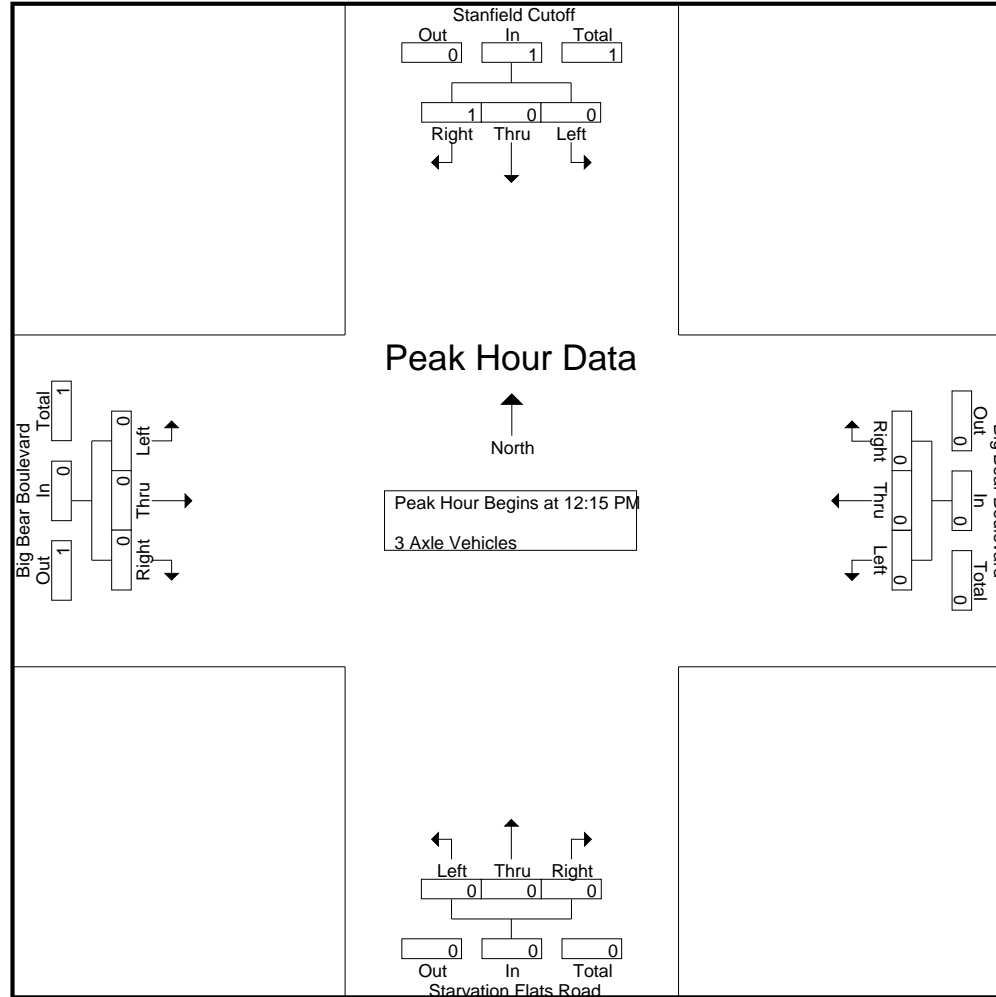

Counts Unlimited
 PO Box 1178
 Corona, CA 92878
 (951) 268-6268

City of Big Bear Lake
 N/S: Stanfield Cutoff/Starvation Flats
 E/W: Big Bear Boulevard (SR-18)
 Weather: Clear

File Name : BBLSTBISUN
 Site Code : 05116469
 Start Date : 9/11/2016
 Page No : 1

Groups Printed- 4+ Axle Trucks

Start Time	Stanfield Cutoff Southbound					Big Bear Boulevard Westbound					Starvation Flats Road Northbound					Big Bear Boulevard Eastbound					Exclu. Total	Inclu. Total	Int. Total			
	Left	Thru	Right	RTOR	App. Total	Left	Thru	Right	RTOR	App. Total	Left	Thru	Right	RTOR	App. Total	Left	Thru	Right	RTOR	App. Total						
12:00 PM	0	0	0	0	0	0	0	0	0	0	0	0	0	0	0	0	0	0	0	0	0	0	0	0	0	0
12:15 PM	0	0	0	0	0	0	0	0	0	0	0	0	0	0	0	0	0	0	0	0	0	0	0	0	0	0
12:30 PM	0	1	0	0	1	0	0	0	0	0	0	0	0	0	0	0	0	0	0	0	0	0	0	0	1	1
12:45 PM	0	0	0	0	0	0	0	0	0	0	0	0	0	0	0	0	0	0	0	0	0	0	0	0	0	0
Total	0	1	0	0	1	0	0	0	0	0	0	0	0	0	0	0	0	0	0	0	0	0	0	0	1	1
01:00 PM	0	0	0	0	0	0	0	0	0	0	0	0	0	0	0	0	0	0	0	0	0	0	0	0	0	0
01:15 PM	0	0	0	0	0	0	0	0	0	0	0	0	0	0	0	0	0	0	0	0	0	0	0	0	0	0
01:30 PM	0	0	0	0	0	0	0	0	0	0	0	0	0	0	0	0	0	0	0	0	0	0	0	0	0	0
01:45 PM	0	0	0	0	0	0	0	0	0	0	0	0	0	0	0	0	0	0	0	0	0	0	0	0	0	0
Total	0	0	0	0	0	0	0	0	0	0	0	0	0	0	0	0	0	0	0	0	0	0	0	0	0	0
Grand Total	0	1	0	0	1	0	0	0	0	0	0	0	0	0	0	0	0	0	0	0	0	0	0	0	1	1
Apprch %	0	100	0			0	0	0			0	0	0			0	0	0			0	0	0			
Total %	0	100	0		100	0	0	0		0	0	0	0		0	0	0	0		0	0	0	0	0	100	

Start Time	Stanfield Cutoff Southbound				Big Bear Boulevard Westbound				Starvation Flats Road Northbound				Big Bear Boulevard Eastbound				Int. Total
	Left	Thru	Right	App. Total	Left	Thru	Right	App. Total	Left	Thru	Right	App. Total	Left	Thru	Right	App. Total	
Peak Hour Analysis From 12:15 PM to 01:00 PM - Peak 1 of 1																	
Peak Hour for Entire Intersection Begins at 12:15 PM																	
12:15 PM	0	0	0	0	0	0	0	0	0	0	0	0	0	0	0	0	0
12:30 PM	0	1	0	1	0	0	0	0	0	0	0	0	0	0	0	0	1
12:45 PM	0	0	0	0	0	0	0	0	0	0	0	0	0	0	0	0	0
01:00 PM	0	0	0	0	0	0	0	0	0	0	0	0	0	0	0	0	0
Total Volume	0	1	0	1	0	0	0	0	0	0	0	0	0	0	0	0	1
% App. Total	0	100	0		0	0	0		0	0	0		0	0	0		
PHF	.000	.250	.000	.250	.000	.000	.000	.000	.000	.000	.000	.000	.000	.000	.000	.000	.250

City of Big Bear Lake
 N/S: Stanfield Cutoff/Starvation Flats
 E/W: Big Bear Boulevard (SR-18)
 Weather: Clear

File Name : BBLSTBISUN
 Site Code : 05116469
 Start Date : 9/11/2016
 Page No : 2

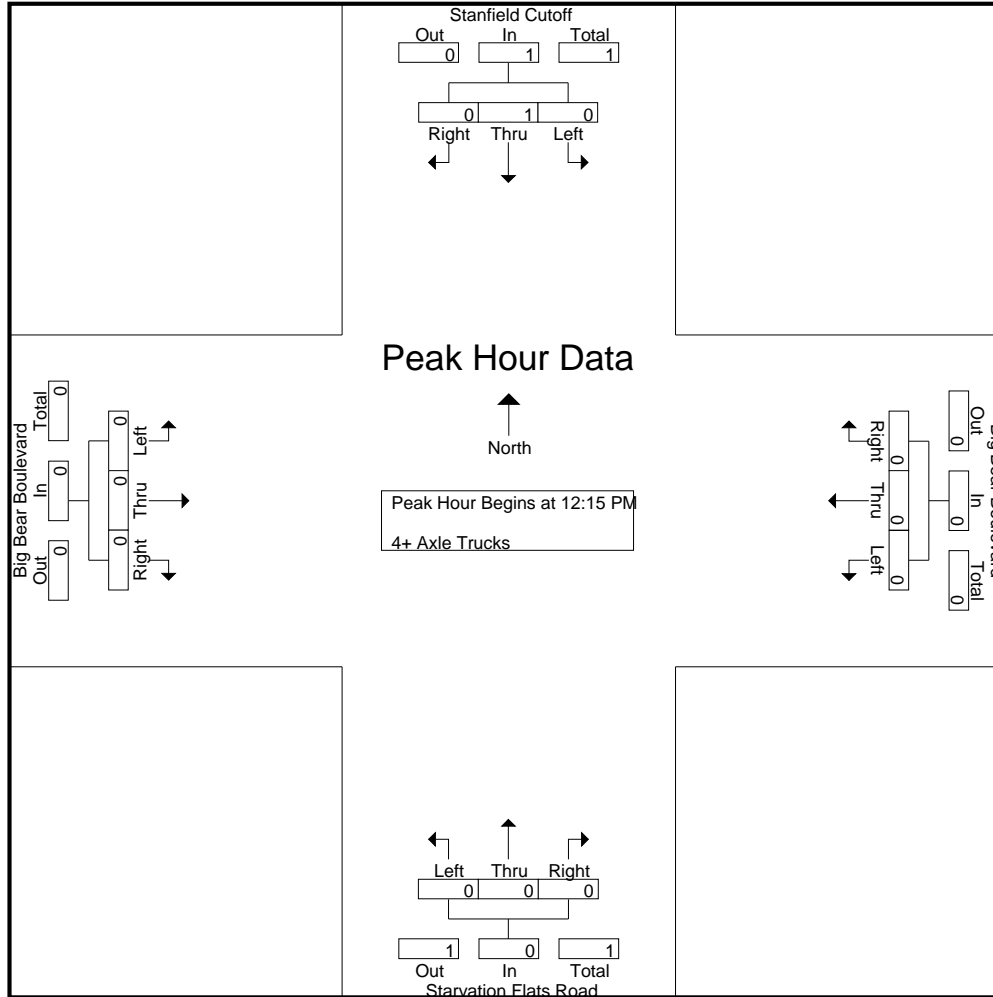

Location: City of Big Bear Lake
 N/S: Stanfield Cutoff/Starvation Flats Rd
 E/W: Big Bear Boulevard (SR-18)



PEDESTRIANS

Date: 9/9/2016

Day: Friday

	North Leg Stanfield Cutoff	East Leg Big Bear Boulevard (SR-18)	South Leg Starvation Flats Road	West Leg Big Bear Boulevard (SR-18)	TOTAL
4:00 PM	1	0	0	1	2
4:15 PM	3	0	0	0	3
4:30 PM	3	2	0	0	5
4:45 PM	0	0	0	0	0
5:00 PM	0	0	0	0	0
5:15 PM	0	0	0	0	0
5:30 PM	0	0	0	0	0
5:45 PM	0	0	0	2	2
TOTAL VOLUMES:	7	2	0	3	12

Date: 9/11/2016

Day: Sunday

	North Leg Stanfield Cutoff	East Leg Big Bear Boulevard (SR-18)	South Leg Starvation Flats Road	West Leg Big Bear Boulevard (SR-18)	TOTAL
12:00 PM	0	0	0	0	0
12:15 PM	0	0	0	0	0
12:30 PM	0	0	0	0	0
12:45 PM	0	0	0	0	0
1:00 PM	0	0	0	0	0
1:15 PM	0	0	0	0	0
1:30 PM	0	0	0	0	0
1:45 PM	0	0	0	0	0
TOTAL VOLUMES:	0	0	0	0	0

Location: City of Big Bear Lake
 N/S: Stanfield Cutoff/Starvation Flats Rd
 E/W: Big Bear Boulevard (SR-18)



BICYCLES

Date: 9/9/2016

Day: Friday

	North Leg Stanfield Cutoff	East Leg Big Bear Boulevard (SR-18)	South Leg Starvation Flats Road	West Leg Big Bear Boulevard (SR-18)	TOTAL
4:00 PM	1	0	0	0	1
4:15 PM	0	0	0	0	0
4:30 PM	0	0	0	0	0
4:45 PM	0	0	0	0	0
5:00 PM	0	0	0	0	0
5:15 PM	1	0	0	0	1
5:30 PM	0	0	0	0	0
5:45 PM	0	0	0	0	0
TOTAL VOLUMES:	2	0	0	0	2

Date: 9/11/2016

Day: Sunday

	North Leg Stanfield Cutoff	East Leg Big Bear Boulevard (SR-18)	South Leg Starvation Flats Road	West Leg Big Bear Boulevard (SR-18)	TOTAL
12:00 PM	0	0	0	0	0
12:15 PM	0	0	0	0	0
12:30 PM	0	0	0	0	0
12:45 PM	0	0	0	0	0
1:00 PM	0	0	0	0	0
1:15 PM	0	0	0	0	0
1:30 PM	0	0	0	0	0
1:45 PM	0	0	0	0	0
TOTAL VOLUMES:	0	0	0	0	0





















ATTACHMENT B:

INTERSECTION CAPACITY ANALYSIS WORKSHEETS, WITH IMPROVEMENTS

HCM 2010 Signalized Intersection Summary
 1: Stanfield Cutoff & North Shore Drive (SR-38)

Moon Camp Focused TIA (JN: 10430)





















10/11/2016

												
Movement	EBL	EBT	EBR	WBL	WBT	WBR	NBL	NBT	NBR	SBL	SBT	SBR
Lane Configurations												
Traffic Volume (veh/h)	0	126	215	265	136	8	239	10	201	15	2	3
Future Volume (veh/h)	0	126	215	265	136	8	239	10	201	15	2	3
Number	7	4	14	3	8	18	5	2	12	1	6	16
Initial Q (Qb), veh	0	0	0	0	0	0	0	0	0	0	0	0
Ped-Bike Adj(A_pbT)	1.00		1.00	1.00		1.00	1.00		1.00	1.00		1.00
Parking Bus, Adj	1.00	1.00	1.00	1.00	1.00	1.00	1.00	1.00	1.00	1.00	1.00	1.00
Adj Sat Flow, veh/h/ln	1700	1800	1800	1700	1800	1800	1700	1800	1800	1700	1800	1800
Adj Flow Rate, veh/h	0	137	234	288	148	9	260	11	218	16	2	3
Adj No. of Lanes	1	1	0	1	1	0	1	1	0	1	1	0
Peak Hour Factor	0.92	0.92	0.92	0.92	0.92	0.92	0.92	0.92	0.92	0.92	0.92	0.92
Percent Heavy Veh, %	0	0	0	0	0	0	0	0	0	0	0	0
Cap, veh/h	2	166	283	337	921	56	308	18	355	31	46	69
Arrive On Green	0.00	0.28	0.28	0.21	0.55	0.55	0.19	0.24	0.24	0.02	0.07	0.07
Sat Flow, veh/h	1619	598	1022	1619	1680	102	1619	74	1467	1619	651	977
Grp Volume(v), veh/h	0	0	371	288	0	157	260	0	229	16	0	5
Grp Sat Flow(s),veh/h/ln	1619	0	1620	1619	0	1782	1619	0	1541	1619	0	1628
Q Serve(g_s), s	0.0	0.0	15.2	12.1	0.0	3.1	11.0	0.0	9.4	0.7	0.0	0.2
Cycle Q Clear(g_c), s	0.0	0.0	15.2	12.1	0.0	3.1	11.0	0.0	9.4	0.7	0.0	0.2
Prop In Lane	1.00		0.63	1.00		0.06	1.00		0.95	1.00		0.60
Lane Grp Cap(c), veh/h	2	0	448	337	0	977	308	0	373	31	0	115
V/C Ratio(X)	0.00	0.00	0.83	0.85	0.00	0.16	0.84	0.00	0.61	0.52	0.00	0.04
Avail Cap(c_a), veh/h	114	0	652	606	0	1259	560	0	897	133	0	517
HCM Platoon Ratio	1.00	1.00	1.00	1.00	1.00	1.00	1.00	1.00	1.00	1.00	1.00	1.00
Upstream Filter(I)	0.00	0.00	1.00	1.00	0.00	1.00	1.00	0.00	1.00	1.00	0.00	1.00
Uniform Delay (d), s/veh	0.0	0.0	24.0	27.0	0.0	7.9	27.6	0.0	23.9	34.4	0.0	30.7
Incr Delay (d2), s/veh	0.0	0.0	5.8	6.2	0.0	0.1	6.3	0.0	1.6	12.8	0.0	0.2
Initial Q Delay(d3),s/veh	0.0	0.0	0.0	0.0	0.0	0.0	0.0	0.0	0.0	0.0	0.0	0.0
%ile BackOfQ(50%),veh/ln	0.0	0.0	7.5	6.0	0.0	1.5	5.4	0.0	4.1	0.4	0.0	0.1
LnGrp Delay(d),s/veh	0.0	0.0	29.8	33.2	0.0	8.0	33.9	0.0	25.5	47.2	0.0	30.8
LnGrp LOS			C	C		A	C		C	D		C
Approach Vol, veh/h		371			445			489			21	
Approach Delay, s/veh		29.8			24.3			30.0			43.3	
Approach LOS		C			C			C			D	
Timer	1	2	3	4	5	6	7	8				
Assigned Phs	1	2	3	4	5	6	7	8				
Phs Duration (G+Y+Rc), s	5.8	21.6	19.2	24.1	18.0	9.5	0.0	43.3				
Change Period (Y+Rc), s	4.5	4.5	4.5	4.5	4.5	4.5	4.5	4.5				
Max Green Setting (Gmax), s	5.8	41.2	26.5	28.5	24.5	22.5	5.0	50.0				
Max Q Clear Time (g_c+I1), s	2.7	11.4	14.1	17.2	13.0	2.2	0.0	5.1				
Green Ext Time (p_c), s	0.0	1.6	0.7	2.4	0.6	1.4	0.0	3.5				
Intersection Summary												
HCM 2010 Ctrl Delay			28.3									
HCM 2010 LOS			C									

HCM 2010 Signalized Intersection Summary
 1: Stanfield Cutoff & North Shore Drive (SR-38)

Moon Camp Focused TIA (JN: 10430)





















10/11/2016

												
Movement	EBL	EBT	EBR	WBL	WBT	WBR	NBL	NBT	NBR	SBL	SBT	SBR
Lane Configurations												
Traffic Volume (veh/h)	0	128	223	265	139	8	252	10	201	15	2	3
Future Volume (veh/h)	0	128	223	265	139	8	252	10	201	15	2	3
Number	7	4	14	3	8	18	5	2	12	1	6	16
Initial Q (Qb), veh	0	0	0	0	0	0	0	0	0	0	0	0
Ped-Bike Adj(A_pbT)	1.00		1.00	1.00		1.00	1.00		1.00	1.00		1.00
Parking Bus, Adj	1.00	1.00	1.00	1.00	1.00	1.00	1.00	1.00	1.00	1.00	1.00	1.00
Adj Sat Flow, veh/h/ln	1700	1800	1800	1700	1800	1800	1700	1800	1800	1700	1800	1800
Adj Flow Rate, veh/h	0	145	253	301	158	9	286	11	228	17	2	3
Adj No. of Lanes	1	1	0	1	1	0	1	1	0	1	1	0
Peak Hour Factor	0.88	0.88	0.88	0.88	0.88	0.88	0.88	0.88	0.88	0.88	0.88	0.88
Percent Heavy Veh, %	0	0	0	0	0	0	0	0	0	0	0	0
Cap, veh/h	2	169	295	345	941	54	330	18	365	32	42	63
Arrive On Green	0.00	0.29	0.29	0.21	0.56	0.56	0.20	0.25	0.25	0.02	0.06	0.06
Sat Flow, veh/h	1619	590	1029	1619	1687	96	1619	71	1470	1619	651	977
Grp Volume(v), veh/h	0	0	398	301	0	167	286	0	239	17	0	5
Grp Sat Flow(s),veh/h/ln	1619	0	1618	1619	0	1783	1619	0	1541	1619	0	1628
Q Serve(g_s), s	0.0	0.0	18.1	13.9	0.0	3.5	13.3	0.0	10.7	0.8	0.0	0.2
Cycle Q Clear(g_c), s	0.0	0.0	18.1	13.9	0.0	3.5	13.3	0.0	10.7	0.8	0.0	0.2
Prop In Lane	1.00		0.64	1.00		0.05	1.00		0.95	1.00		0.60
Lane Grp Cap(c), veh/h	2	0	464	345	0	995	330	0	383	32	0	105
V/C Ratio(X)	0.00	0.00	0.86	0.87	0.00	0.17	0.87	0.00	0.62	0.53	0.00	0.05
Avail Cap(c_a), veh/h	104	0	595	553	0	1149	511	0	818	121	0	472
HCM Platoon Ratio	1.00	1.00	1.00	1.00	1.00	1.00	1.00	1.00	1.00	1.00	1.00	1.00
Upstream Filter(I)	0.00	0.00	1.00	1.00	0.00	1.00	1.00	0.00	1.00	1.00	0.00	1.00
Uniform Delay (d), s/veh	0.0	0.0	26.2	29.5	0.0	8.4	29.9	0.0	25.9	37.7	0.0	34.1
Incr Delay (d2), s/veh	0.0	0.0	9.8	8.7	0.0	0.1	9.5	0.0	1.7	13.0	0.0	0.2
Initial Q Delay(d3),s/veh	0.0	0.0	0.0	0.0	0.0	0.0	0.0	0.0	0.0	0.0	0.0	0.0
%ile BackOfQ(50%),veh/ln	0.0	0.0	9.3	7.0	0.0	1.7	6.7	0.0	4.7	0.5	0.0	0.1
LnGrp Delay(d),s/veh	0.0	0.0	36.0	38.2	0.0	8.4	39.4	0.0	27.6	50.6	0.0	34.2
LnGrp LOS			D	D		A	D		C	D		C
Approach Vol, veh/h		398			468			525			22	
Approach Delay, s/veh		36.0			27.6			34.0			46.9	
Approach LOS		D			C			C			D	
Timer	1	2	3	4	5	6	7	8				
Assigned Phs	1	2	3	4	5	6	7	8				
Phs Duration (G+Y+Rc), s	6.0	23.8	21.1	26.7	20.3	9.5	0.0	47.8				
Change Period (Y+Rc), s	4.5	4.5	4.5	4.5	4.5	4.5	4.5	4.5				
Max Green Setting (Gmax), s	5.8	41.2	26.5	28.5	24.5	22.5	5.0	50.0				
Max Q Clear Time (g_c+I1), s	2.8	12.7	15.9	20.1	15.3	2.2	0.0	5.5				
Green Ext Time (p_c), s	0.0	1.6	0.6	2.2	0.6	1.5	0.0	3.8				
Intersection Summary												
HCM 2010 Ctrl Delay			32.7									
HCM 2010 LOS			C									

HCM 2010 Signalized Intersection Summary
 1: Stanfield Cutoff & North Shore Drive (SR-38)

Moon Camp Focused TIA (JN: 10430)





















10/11/2016

												
Movement	EBL	EBT	EBR	WBL	WBT	WBR	NBL	NBT	NBR	SBL	SBT	SBR
Lane Configurations												
Traffic Volume (veh/h)	0	139	237	292	150	9	263	11	221	17	2	4
Future Volume (veh/h)	0	139	237	292	150	9	263	11	221	17	2	4
Number	7	4	14	3	8	18	5	2	12	1	6	16
Initial Q (Qb), veh	0	0	0	0	0	0	0	0	0	0	0	0
Ped-Bike Adj(A_pbT)	1.00		1.00	1.00		1.00	1.00		1.00	1.00		1.00
Parking Bus, Adj	1.00	1.00	1.00	1.00	1.00	1.00	1.00	1.00	1.00	1.00	1.00	1.00
Adj Sat Flow, veh/h/ln	1800	1900	1900	1800	1900	1900	1700	1900	1900	1800	1900	1900
Adj Flow Rate, veh/h	0	151	258	317	163	10	286	12	240	18	2	4
Adj No. of Lanes	1	1	1	1	1	0	2	1	0	1	1	0
Peak Hour Factor	0.92	0.92	0.92	0.92	0.92	0.92	0.92	0.92	0.92	0.92	0.92	0.92
Percent Heavy Veh, %	0	0	0	0	0	0	0	0	0	0	0	0
Cap, veh/h	3	385	549	390	910	56	430	17	331	38	56	112
Arrive On Green	0.00	0.20	0.20	0.23	0.51	0.51	0.14	0.21	0.21	0.02	0.10	0.10
Sat Flow, veh/h	1714	1900	1615	1714	1772	109	3141	77	1549	1714	567	1133
Grp Volume(v), veh/h	0	151	258	317	0	173	286	0	252	18	0	6
Grp Sat Flow(s),veh/h/ln	1714	1900	1615	1714	0	1881	1570	0	1627	1714	0	1700
Q Serve(g_s), s	0.0	3.7	6.8	9.4	0.0	2.7	4.7	0.0	7.8	0.6	0.0	0.2
Cycle Q Clear(g_c), s	0.0	3.7	6.8	9.4	0.0	2.7	4.7	0.0	7.8	0.6	0.0	0.2
Prop In Lane	1.00		1.00	1.00		0.06	1.00		0.95	1.00		0.67
Lane Grp Cap(c), veh/h	3	385	549	390	0	966	430	0	347	38	0	167
V/C Ratio(X)	0.00	0.39	0.47	0.81	0.00	0.18	0.66	0.00	0.73	0.48	0.00	0.04
Avail Cap(c_a), veh/h	159	759	866	1195	0	1887	1197	0	1103	207	0	711
HCM Platoon Ratio	1.00	1.00	1.00	1.00	1.00	1.00	1.00	1.00	1.00	1.00	1.00	1.00
Upstream Filter(I)	0.00	1.00	1.00	1.00	0.00	1.00	1.00	0.00	1.00	1.00	0.00	1.00
Uniform Delay (d), s/veh	0.0	18.6	14.0	19.7	0.0	7.0	22.0	0.0	19.7	26.0	0.0	21.9
Incr Delay (d2), s/veh	0.0	0.6	0.6	4.1	0.0	0.1	1.8	0.0	2.9	9.2	0.0	0.1
Initial Q Delay(d3),s/veh	0.0	0.0	0.0	0.0	0.0	0.0	0.0	0.0	0.0	0.0	0.0	0.0
%ile BackOfQ(50%),veh/ln	0.0	2.0	3.1	4.9	0.0	1.4	2.1	0.0	3.7	0.4	0.0	0.1
LnGrp Delay(d),s/veh	0.0	19.2	14.6	23.8	0.0	7.1	23.8	0.0	22.6	35.2	0.0	22.0
LnGrp LOS		B	B	C		A	C		C	D		C
Approach Vol, veh/h		409			490			538			24	
Approach Delay, s/veh		16.3			17.9			23.2			31.9	
Approach LOS		B			B			C			C	
Timer	1	2	3	4	5	6	7	8				
Assigned Phs	1	2	3	4	5	6	7	8				
Phs Duration (G+Y+Rc), s	5.7	16.0	16.7	15.4	11.9	9.8	0.0	32.1				
Change Period (Y+Rc), s	4.5	4.5	4.5	4.5	4.5	4.5	4.5	4.5				
Max Green Setting (Gmax), s	6.5	36.5	37.5	21.5	20.5	22.5	5.0	54.0				
Max Q Clear Time (g_c+I1), s	2.6	9.8	11.4	8.8	6.7	2.2	0.0	4.7				
Green Ext Time (p_c), s	0.0	1.7	0.9	2.2	0.8	1.6	0.0	2.8				
Intersection Summary												
HCM 2010 Ctrl Delay			19.7									
HCM 2010 LOS			B									

HCM 2010 Signalized Intersection Summary
 1: Stanfield Cutoff & North Shore Drive (SR-38)

Moon Camp Focused TIA (JN: 10430)

10/11/2016

												
Movement	EBL	EBT	EBR	WBL	WBT	WBR	NBL	NBT	NBR	SBL	SBT	SBR
Lane Configurations												
Traffic Volume (veh/h)	0	141	245	292	153	9	276	11	221	17	2	4
Future Volume (veh/h)	0	141	245	292	153	9	276	11	221	17	2	4
Number	7	4	14	3	8	18	5	2	12	1	6	16
Initial Q (Qb), veh	0	0	0	0	0	0	0	0	0	0	0	0
Ped-Bike Adj(A_pbT)	1.00		1.00	1.00		1.00	1.00		1.00	1.00		1.00
Parking Bus, Adj	1.00	1.00	1.00	1.00	1.00	1.00	1.00	1.00	1.00	1.00	1.00	1.00
Adj Sat Flow, veh/h/ln	1800	1900	1900	1800	1900	1900	1700	1900	1900	1800	1900	1900
Adj Flow Rate, veh/h	0	153	266	317	166	10	300	12	240	18	2	4
Adj No. of Lanes	1	1	1	1	1	0	2	1	0	1	1	0
Peak Hour Factor	0.92	0.92	0.92	0.92	0.92	0.92	0.92	0.92	0.92	0.92	0.92	0.92
Percent Heavy Veh, %	0	0	0	0	0	0	0	0	0	0	0	0
Cap, veh/h	3	391	562	389	916	55	446	17	330	38	53	105
Arrive On Green	0.00	0.21	0.21	0.23	0.52	0.52	0.14	0.21	0.21	0.02	0.09	0.09
Sat Flow, veh/h	1714	1900	1615	1714	1774	107	3141	77	1549	1714	567	1133
Grp Volume(v), veh/h	0	153	266	317	0	176	300	0	252	18	0	6
Grp Sat Flow(s),veh/h/ln	1714	1900	1615	1714	0	1881	1570	0	1627	1714	0	1700
Q Serve(g_s), s	0.0	3.8	7.0	9.5	0.0	2.7	4.9	0.0	7.8	0.6	0.0	0.2
Cycle Q Clear(g_c), s	0.0	3.8	7.0	9.5	0.0	2.7	4.9	0.0	7.8	0.6	0.0	0.2
Prop In Lane	1.00		1.00	1.00		0.06	1.00		0.95	1.00		0.67
Lane Grp Cap(c), veh/h	3	391	562	389	0	971	446	0	347	38	0	158
V/C Ratio(X)	0.00	0.39	0.47	0.81	0.00	0.18	0.67	0.00	0.73	0.48	0.00	0.04
Avail Cap(c_a), veh/h	158	754	870	1186	0	1874	1188	0	1095	206	0	706
HCM Platoon Ratio	1.00	1.00	1.00	1.00	1.00	1.00	1.00	1.00	1.00	1.00	1.00	1.00
Upstream Filter(I)	0.00	1.00	1.00	1.00	0.00	1.00	1.00	0.00	1.00	1.00	0.00	1.00
Uniform Delay (d), s/veh	0.0	18.6	13.8	19.9	0.0	7.0	22.1	0.0	19.9	26.2	0.0	22.4
Incr Delay (d2), s/veh	0.0	0.6	0.6	4.2	0.0	0.1	1.8	0.0	2.9	9.2	0.0	0.1
Initial Q Delay(d3),s/veh	0.0	0.0	0.0	0.0	0.0	0.0	0.0	0.0	0.0	0.0	0.0	0.0
%ile BackOfQ(50%),veh/ln	0.0	2.0	3.2	4.9	0.0	1.4	2.2	0.0	3.8	0.4	0.0	0.1
LnGrp Delay(d),s/veh	0.0	19.2	14.4	24.0	0.0	7.1	23.8	0.0	22.8	35.4	0.0	22.5
LnGrp LOS		B	B	C		A	C		C	D		C
Approach Vol, veh/h		419			493			552			24	
Approach Delay, s/veh		16.2			18.0			23.4			32.2	
Approach LOS		B			B			C			C	
Timer	1	2	3	4	5	6	7	8				
Assigned Phs	1	2	3	4	5	6	7	8				
Phs Duration (G+Y+Rc), s	5.7	16.0	16.8	15.7	12.2	9.5	0.0	32.5				
Change Period (Y+Rc), s	4.5	4.5	4.5	4.5	4.5	4.5	4.5	4.5				
Max Green Setting (Gmax), s	6.5	36.5	37.5	21.5	20.5	22.5	5.0	54.0				
Max Q Clear Time (g_c+I1), s	2.6	9.8	11.5	9.0	6.9	2.2	0.0	4.7				
Green Ext Time (p_c), s	0.0	1.7	0.9	2.2	0.9	1.6	0.0	2.8				
Intersection Summary												
HCM 2010 Ctrl Delay			19.7									
HCM 2010 LOS			B									

ATTACHMENT C:

TRAFFIC SIGNAL WARRANT ANALYSIS WORKSHEETS

TRAFFIC SIGNAL WARRANTS

(Based on Estimated Average Daily Traffic-See Note 2)

Major St: **DWY 1** Minor St: **North Shore** Year = **GP FRI**
 Volume = **20,000** Lanes= **1** Volume = **200** Lanes= **1** (one-way)

URBAN		RURAL XX		Minimum Requirements EADT							
1. Minimum Vehicular		Satisfied		Not Satisfied XX		Vehicles per day on major street (both approaches)		Vehicles per day on higher volume minor-street approach (one direction only)			
Number of lanes for moving traffic on each approach.				Urban		Rural		Urban		Rural	
Major Street		Minor Street									
1	20,000	1	200	8,000	5,600 *	2,400	1,680	2,400	1,680		
2 +		1		9,600	6,720	2,400	1,680	2,400	1,680		
2 +		2 +		9,600	6,720	3,200	2,240	3,200	2,240		
1		2 +		8,000	5,600	3,200	2,240	3,200	2,240		
2. Interruption of Continuous traffic		Satisfied		Not Satisfied XX		Vehicles per day on major street (both approaches)		Vehicles per day on higher volume minor-street approach (one direction only)			
Number of lanes for moving traffic on each approach.				Urban		Rural		Urban		Rural	
Major Street		Minor Street									
1	20,000	1	200	12,000	8,400 *	1,200	850	1,200	850		
2 +		1		14,400	10,080	1,200	850	1,200	850		
2 +		2 +		14,000	10,080	1,600	1,120	1,600	1,120		
1		2 +		12,000	8,400	1,600	1,120	1,600	1,120		
3. Combination		Satisfied		Not Satisfied XX		2 Warrants		2 Warrants			
No one warrant satisfied but following warrants fulfilled 80% or more..											
12%		24%									
1		2									

NOTES: 1. Heavier left turn movement from the major street may be included with minor street volume if a separate signal phase is to be provided for the left-turn movement.

2. To be used only for NEW INTERSECTIONS or other locations where actual traffic volumes cannot be counted.

TRAFFIC SIGNAL WARRANTS

(Based on Estimated Average Daily Traffic-See Note 2)

Major St: **DWY 1** Minor St: **North Shore** Year = **GP Sun**
 Volume = **15,000** Lanes= **1** Volume = **200** Lanes= **1** (one-way)

URBAN		RURAL XX		Minimum Requirements EADT			
1. Minimum Vehicular				Vehicles per day on major street (both approaches)		Vehicles per day on higher volume minor-street approach (one direction only)	
Satisfied		Not Satisfied XX					
Number of lanes for moving traffic on each approach.							
Major Street		Minor Street		Urban	Rural	Urban	Rural
1	15,000	1	200	8,000	5,600 *	2,400	1,680
2 +		1		9,600	6,720	2,400	1,680
2 +		2 +		9,600	6,720	3,200	2,240
1		2 +		8,000	5,600	3,200	2,240
2. Interruption of Continuous traffic				Vehicles per day on major street (both approaches)		Vehicles per day on higher volume minor-street approach (one direction only)	
Satisfied		Not Satisfied XX					
Number of lanes for moving traffic on each approach.							
Major Street		Minor Street		Urban	Rural	Urban	Rural
1	15,000	1	200	12,000	8,400 *	1,200	850
2 +		1		14,400	10,080	1,200	850
2 +		2 +		14,000	10,080	1,600	1,120
1		2 +		12,000	8,400	1,600	1,120
3. Combination				2 Warrants		2 Warrants	
Satisfied		Not Satisfied XX					
No one warrant satisfied but following warrants fulfilled 80% or more..							
12%		24%					
1		2					

NOTES: 1. Heavier left turn movement from the major street may be included with minor street volume if a separate signal phase is to be provided for the left-turn movement.
 2. To be used only for NEW INTERSECTIONS or other locations where actual traffic volumes cannot be counted.

TRAFFIC SIGNAL WARRANTS

(Based on Estimated Average Daily Traffic-See Note 2)

Major St: **DWY 2** Minor St: **North Shore** Year = **GP FRI**
 Volume = **20,000** Lanes= **1** Volume = **400** Lanes= **1** (one-way)

URBAN		RURAL XX		Minimum Requirements EADT							
1. Minimum Vehicular		Satisfied		Not Satisfied XX		Vehicles per day on major street (both approaches)		Vehicles per day on higher volume minor-street approach (one direction only)			
Number of lanes for moving traffic on each approach.				Urban		Rural		Urban		Rural	
Major Street		Minor Street									
1	20,000	1	400	8,000	5,600 *	2,400	1,680	2,400	1,680	2,400	2,240
2 +		1		9,600	6,720	2,400	1,680	3,200	2,240	3,200	2,240
2 +		2 +		9,600	6,720	3,200	2,240	3,200	2,240	3,200	2,240
1		2 +		8,000	5,600	3,200	2,240	3,200	2,240	3,200	2,240
2. Interruption of Continuous traffic		Satisfied		Not Satisfied XX		Vehicles per day on major street (both approaches)		Vehicles per day on higher volume minor-street approach (one direction only)			
Number of lanes for moving traffic on each approach.				Urban		Rural		Urban		Rural	
Major Street		Minor Street									
1	20,000	1	400	12,000	8,400 *	1,200	850	1,200	850	1,600	1,120
2 +		1		14,400	10,080	1,200	850	1,600	1,120	1,600	1,120
2 +		2 +		14,000	10,080	1,600	1,120	1,600	1,120	1,600	1,120
1		2 +		12,000	8,400	1,600	1,120	1,600	1,120	1,600	1,120
3. Combination		Satisfied		Not Satisfied XX		2 Warrants		2 Warrants			
No one warrant satisfied but following warrants fulfilled 80% or more..											
24%		47%									
1		2									

NOTES: 1. Heavier left turn movement from the major street may be included with minor street volume if a separate signal phase is to be provided for the left-turn movement.

2. To be used only for NEW INTERSECTIONS or other locations where actual traffic volumes cannot be counted.

TRAFFIC SIGNAL WARRANTS

(Based on Estimated Average Daily Traffic-See Note 2)

Major St: **DWY 2** Minor St: **North Shore** Year = **GP SUN**
 Volume = **15,000** Lanes= **1** Volume = **400** Lanes= **1** (one-way)

URBAN		RURAL XX		Minimum Requirements EADT							
1. Minimum Vehicular		Satisfied		Not Satisfied XX		Vehicles per day on major street (both approaches)		Vehicles per day on higher volume minor-street approach (one direction only)			
Number of lanes for moving traffic on each approach.				Urban		Rural		Urban		Rural	
Major Street		Minor Street									
1	15,000	1	400	8,000	5,600 *	2,400	1,680	2,400	1,680	2,400	2,240
2 +		1		9,600	6,720	2,400	1,680	3,200	2,240	3,200	2,240
2 +		2 +		9,600	6,720	3,200	2,240	3,200	2,240	3,200	2,240
1		2 +		8,000	5,600	3,200	2,240	3,200	2,240	3,200	2,240
2. Interruption of Continuous traffic		Satisfied		Not Satisfied XX		Vehicles per day on major street (both approaches)		Vehicles per day on higher volume minor-street approach (one direction only)			
Number of lanes for moving traffic on each approach.				Urban		Rural		Urban		Rural	
Major Street		Minor Street									
1	15,000	1	400	12,000	8,400 *	1,200	850	1,200	850	1,600	1,120
2 +		1		14,400	10,080	1,200	850	1,600	1,120	1,600	1,120
2 +		2 +		14,000	10,080	1,600	1,120	1,600	1,120	1,600	1,120
1		2 +		12,000	8,400	1,600	1,120	1,600	1,120	1,600	1,120
3. Combination		Satisfied		Not Satisfied XX		2 Warrants		2 Warrants			
No one warrant satisfied but following warrants fulfilled 80% or more..											
24%		47%									
1		2									

NOTES: 1. Heavier left turn movement from the major street may be included with minor street volume if a separate signal phase is to be provided for the left-turn movement.

2. To be used only for NEW INTERSECTIONS or other locations where actual traffic volumes cannot be counted.

THIS PAGE INTENTIONALLY LEFT BLANK