

Appendix I
Traffic Impact Analysis

I-15 Logistics Project
Draft Environmental Impact Report

This page was intentionally left blank.

TRAFFIC IMPACT ANALYSIS

I-15 Logistics Center

*Prepared for: The City of Fontana
8353 Sierra Avenue
Fontana, CA 92335*

*Project Applicant: Caprock Partners
2050 Main Street, Suite 240
Irvine, CA 92614*

April 9, 2019

TABLE OF CONTENTS

1	EXECUTIVE SUMMARY	1
2	INTRODUCTION	4
2.1	Study Area.....	4
2.2	Analysis Methodology.....	8
2.2.1	Intersection Analysis Methodology	8
2.2.2	Roadway Segment Analysis Methodology.....	8
2.2.3	Freeway Segment Analysis Methodology.....	9
2.2.4	Freeway Merge/Diverge Analysis Methodology.....	10
2.3	Thresholds of Significance.....	10
3	EXISTING CONDITIONS	12
3.1	Surrounding Roadway Network.....	12
3.2	Existing City of Fontana Circulation Plan	12
3.3	Existing Conditions Traffic Volumes.....	14
3.4	Existing Conditions Peak Hour Study Intersection LOS.....	14
3.5	Existing Conditions Roadway Segment LOS.....	15
4	PROPOSED PROJECT	18
4.1	Project Forecast Trip Generation.....	18
4.2	Trip Distribution and Trip Assignment of Proposed Project.....	19
5	EXISTING WITH PROJECT CONDITIONS	23
5.1	Existing With Project Conditions Traffic Volumes.....	23
5.2	Existing With Project Conditions Peak Hour Study Intersection LOS.....	23
5.3	Existing With Project Conditions Roadway Segment LOS.....	27
6	OPENING YEAR 2020 WITHOUT PROJECT CONDITIONS	28
6.1	Opening Year 2020 Without Project Conditions Traffic Volumes.....	28
6.2	Opening Year 2020 Without Project Conditions Peak Hour Study Intersection LOS.....	34
6.3	Opening Year 2020 Without Project Street Segment LOS.....	35

7	Opening Year 2020 WITH PROJECT CONDITIONS.....	36
7.1	Opening Year 2020 With Project Conditions Traffic Volumes	36
7.2	Opening Year 2020 With Project Conditions Peak Hour Study Intersection LOS	36
7.3	Opening Year 2020 With Project Conditions Roadway Segment LOS	38
8	HORIZON YEAR 2040 WITHOUT PROJECT CONDITIONS	39
8.1	Horizon Year 2040 Without Project Conditons Traffic Volumes.....	39
8.2	Horizon Year 2040 Without Project Conditions Peak Hour Study Intersection LOS.....	39
8.3	Horizon Year 2040 Without Project Roadway Segment LOS	42
9	HORIZON YEAR 2040 WITH PROJECT CONDITIONS.....	43
9.1	Horizon Year 2040 With Project Conditions Traffic Volumes	43
9.2	Horizon Year 2040 With Project Conditions Peak Hour Study Intersection LOS	43
9.3	Horizon Year 2040 With Project Roadway Segment LOS.....	45
10	FREEWAY MAINLINE ANALYSIS.....	46
11	FREEWAY RAMP MERGE/DIVERGE ANALYSIS.....	49
12	FINDINGS AND RECOMMENDATIONS	52

LIST OF EXHIBITS

Exhibit 1, Regional Project Location	5
Exhibit 2, Project Site Plan	6
Exhibit 3, Project Study Area.....	7
Exhibit 4, City of Fontana Circulation Element Roadway Functional Classification.....	13
Exhibit 5, Existing Lane Configurations	16
Exhibit 6, Existing AM/PM Peak Hour & Daily Volumes	17
Exhibit 7, Project Inbound/Outbound Distribution – Passenger Cars	20
Exhibit 8, Project Inbound/Outbound Distribution – Trucks	21
Exhibit 9, Project Only AM/PM Peak Hour & Daily Volumes (Passenger Cars & Trucks)	22
Exhibit 10, Existing With Project AM/PM Peak Hour & Daily Volumes	24

Exhibit 11, Existing With Project Lane Configurations.....	25
Exhibit 12, Cumulative Project Location Map.....	31
Exhibit 13, Cumulative Projects AM/PM Peak Hour & Daily Volumes	32
Exhibit 14, Opening Year 2020 Without Project AM/PM Peak Hour & Daily Volumes	33
Exhibit 15, Opening Year 2020 With Project AM/PM Peak Hour & Daily Volumes.....	37
Exhibit 16, Horizon Year 2040 Without Project Lane Configurations.....	40
Exhibit 17, Horizon Year 2040 Without Project AM/PM Peak Hour & Daily Volumes	41
Exhibit 18, Horizon Year 2040 With Project AM/PM Peak Hour & Daily Volumes.....	44

LIST OF TABLES

Table 1, Summary of Peak Hour Intersection Operations With Mitigation.....	3
Table 2, Level of Service & Delay Range - Intersections	8
Table 3, Level of Service Ranges – Roadway Segments.....	9
Table 4, Level of Service Criteria – Freeway Segments.....	9
Table 5, Level of Service Criteria – Ramp & Ramp Junctions.....	10
Table 6, Thresholds of Significant Impacts - Intersections	10
Table 7, Existing Conditions AM/PM Peak Hour Intersection LOS.....	14
Table 8, Existing Conditions Roadway Segment LOS	15
Table 9, ITE Trip Generation Rates.....	18
Table 10, Proposed Project Trip Generation in Vehicles	19
Table 11, Existing With Project Conditions AM/PM Peak Hour Intersection LOS	26
Table 12, Existing With Project Conditions Roadway Segment LOS.....	27
Table 13, Cumulative Projects Trip	29
Table 14, Opening Year 2020 Without Project Conditions AM/PM Peak Hour Intersection LOS	34
Table 15, Opening Year 2020 Without Project Conditions Roadway Segment LOS	35
Table 16, Opening Year 2020 With Project Conditions AM/PM Peak Hour Intersection LOS.....	36

Table 17, Opening Year 2020 With Project Conditions Roadway Segment LOS..... 38

Table 18, Horizon Year 2040 Without Project Conditions AM/PM Peak Hour Intersection LOS 42

Table 19, Horizon Year 2040 Without Project Roadway Segment LOS 42

Table 20, Horizon Year 2040 With Project Conditions AM/PM Peak Hour Intersection LOS 43

Table 21, Horizon Year 2040 With Project Roadway Segment LOS 45

Table 22, Existing Freeway Mainline Segment LOS 46

Table 23, Existing With Project Freeway Mainline Segment LOS 47

Table 24, Opening Year 2020 Without Project Freeway Mainline Segment LOS 47

Table 25, Opening Year 2020 With Project Freeway Mainline Segment LOS..... 47

Table 26, Horizon Year 2040 Without Project Freeway Mainline Segment LOS 48

Table 27, Horizon Year 2040 With Project Freeway Mainline Segment LOS..... 48

Table 28, Existing Freeway Ramp Merge/Diverge LOS 49

Table 29, Existing With Project Freeway Ramp Merge/Diverge LOS..... 50

Table 30, Opening Year 2020 Without Project Freeway Ramp Merge/Diverge LOS..... 50

Table 31, Opening Year 2020 With Project Freeway Ramp Merge/Diverge LOS 51

Table 32, Horizon Year 2040 Without Project Freeway Ramp Merge/Diverge LOS..... 51

Table 33, Horizon Year 2040 With Project Freeway Ramp Merge/Diverge LOS 51

Table 34, Summary of Peak Hour Intersection Operations With Mitigation..... 54

APPENDICES

Appendix A: Count Data & Signal Warrants

Appendix B: Traffic Study Scoping Agreement

Appendix C: Existing Synchro Worksheets

Appendix D: Existing With Project Synchro Worksheets

Appendix E: Opening Year 2020 Without Project Synchro Worksheets

Appendix F: Opening Year 2020 With Project Synchro Worksheets

Appendix G: Horizon Year 2040 Without Project Synchro Worksheets

Appendix H: Horizon Year 2040 With Project Synchro Worksheets

Appendix I: Freeway Mainline Analysis Worksheets

Appendix J: Freeway Ramp Merge/Diverge Analysis Worksheets

1 EXECUTIVE SUMMARY

This study analyzes the forecast traffic conditions associated with the proposed I-15 Logistics Center project located in the County of San Bernardino within the City of Fontana's Sphere of Influence. The project site occupies approximately 75.76 acres southeast of Lytle Creek Road between Duncan Canyon Road and Sierra Avenue.

The project proposes to construct a 1,175,720 square foot warehouse (ITE Land Use Code 150).

The proposed project is forecast to generate approximately 2,046 vehicle trips per day, with approximately 200 trips occurring during the AM peak hour and approximately 223 trips occurring during the PM peak hour. To account for the truck trips generated by the project, vehicular trips have been converted to passenger car equivalent (PCE) trips. Once converted to PCE's, the proposed project is forecast to generate 3,122 PCE trips per day with approximately 305 trips occurring during the AM peak hour and approximately 340 trips occurring during the PM peak hour.

The City of Fontana's designated sphere of influence includes most, but not all of the project site. Therefore, an expansion of the City's sphere of influence is proposed to include the entire project area. The proposed project site would include approximately 20 parcels and portions of the road right-of-way for Lytle Creek Road, Sierra Avenue, and I-15. **This document addresses the potential traffic impacts of the proposed warehouse building.**

The project will also include the construction of new Lytle Creek Road to Sierra Avenue extension from the property's northern boundary and continuing northeast for approximately 0.42 miles. All "With Project" scenarios for this traffic study includes this partial realignment. In addition, the southwest portion of Lytle Creek Road is also planned to be realigned with the existing Coyote Canyon Road and is assumed to be constructed by Opening Year by other parties.

Existing With Project Conditions - Summary of Impacts & Mitigation

The results of the Existing With Project conditions show the following study intersections are forecast to operate at deficient levels of service (LOS D, E or F) with the addition of project-related traffic volumes:

- Sierra Avenue / I-15 Southbound Ramps (LOS F in AM peak hour)
- Sierra Avenue / Riverside Avenue (LOS F in AM & PM peak hour)

According to the *City of Fontana's Traffic Impact Analysis Guidelines* significance criteria, the following intersection would result in a direct significant impact and mitigation is required:

- **Sierra Avenue / Riverside Avenue (Direct Impact) – See Table 1**

The results of the roadway segment analysis along Lytle Creek Road show that all study segments are forecast to operate at acceptable levels of service (C or better) under Existing With Project conditions. Therefore, no significant impacts have been identified and no mitigation measures are required on study roadway segments.

Opening Year 2020 With Project Conditions - Summary of Impacts & Mitigation

The results of the analysis under Opening Year 2020 With Project conditions show the following study intersections are forecast to operate at deficient levels of service (LOS D, E or F) with the addition of project-related traffic volumes:

- Sierra Avenue / I-15 Southbound Ramps (LOS F in AM peak hour)
- Sierra Avenue / I-15 Northbound Ramps (LOS F in PM peak hour)
- Sierra Avenue / Riverside Avenue (LOS D in AM & PM peak hour)

According to the *City of Fontana's Traffic Impact Analysis Guidelines* significance criteria, the following intersections would result in a near-term cumulative significant impact and mitigation is required:

- **Sierra Avenue / I-15 NB Ramps (Near-Term Cumulative Impact) – See Table 1**

The results of the roadway segment analysis along Lytle Creek Road show that all study segments are forecast to operate at acceptable levels of service (C or better) under Opening Year 2020 With Project conditions. Therefore, no significant impacts have been identified and no mitigation measures are required.

Horizon Year 2040 With Project Conditions - Summary of Impacts & Mitigation

The results of the analysis under Horizon Year 2040 With Project conditions show the following study intersections are forecast to operate at deficient levels of service (LOS D, E or F) with the addition of project-related traffic volumes:

- Sierra Avenue / Lytle Creek Road (With Realignment) (LOS D in AM & PM peak hour)
- Sierra Avenue / Riverside Avenue (LOS D in PM peak hour)

According to the *City of Fontana's Traffic Impact Analysis Guidelines* significance criteria, the following intersections would result in a long-term cumulative significant impact and mitigation is required:

- **Sierra Avenue / I-15 SB Ramps (Long-Term Cumulative Impact) – See Table 1**
- **Sierra Avenue / I-15 NB Ramps (Long-Term Cumulative Impact) – See Table 1**

The results of the roadway segment analysis along Lytle Creek Road show that all study segments are forecast to operate at acceptable levels of service (C or better) under Horizon Year 2040 With Project conditions. Therefore, no significant impacts have been identified and no mitigation measures are required.

Table 1 summarizes the recommended mitigation measures and fair share contributions toward the intersection improvements.

TABLE 1, SUMMARY OF PEAK HOUR INTERSECTION OPERATIONS WITH MITIGATION

Int. #	Intersection	Peak Hour	Without Project	With Project	Recommended Mitigation	With Project With Mitigation	Project Responsibility (%)
			Delay ⁽¹⁾ – LOS	Delay ⁽¹⁾ – LOS		Delay ⁽¹⁾ – LOS	
Existing With Project Conditions							
9	Riverside Avenue / Sierra Avenue	AM	60.8 - E	70.3 - F	The City of Fontana is planning to construct an additional northbound lane on Sierra Avenue and install a new traffic signal. Current construction schedule is unknown, however plans have been developed and construction may occur in 2020. No additional mitigation is required of the project applicant.	17.9 – B	0%
		PM	>80.0 - F	>80.0 - F		22.7 – C	0%
Opening Year 2020 With Project Conditions							
8	Sierra Avenue / I-15 NB Ramps	PM	>80.0 - F	>80.0 - F	(2)	(2)	(2)
Horizon Year 2040 With Project Conditions							
7	Sierra Avenue / I-15 SB Ramps	AM	>80.0 - F	>80.0 - F	(2)	(2)	(2)
8	Sierra Avenue / I-15 NB Ramps	AM	74.2 – E	>80.0 – F	(2)	(2)	(2)
		PM	>80.0 – F	>80.0 – F			

(1) Seconds of delay per vehicle.

(2) There are no specific improvements identified at the I-15/Sierra Ave. interchange by Caltrans or San Bernardino County, therefore, no mitigation is proposed by the project. The project-related traffic impact at this location is considered significant and unavoidable.

Freeway Mainline & Ramp Analysis Summary

Under Existing and Existing With Project conditions, all three study freeway mainline segments are operating at LOS D. In Opening Year 2020 Without and With Project conditions, freeway segments analyzed are forecast to operate at LOS E. For the Horizon Year 2040 Without and With Project conditions, the results of the analysis show freeway segments forecast to operate at LOS F.

Freeway on and off ramps at Sierra Avenue are currently operating at LOS C, D, and E for Existing and Existing With Project conditions. In Opening Year 2020 and Horizon Year 2040 Without and With Project conditions, freeway on and off ramps analyzed are forecast to operate at LOS F.

Improvements to the I-15 corridor in this area are not currently planned or funded, thus mitigation measures have not been proposed and impacts are considered significant and unavoidable.

2 INTRODUCTION

This study analyzes the forecast traffic conditions associated with the proposed I-15 Logistics Center project located in the County of San Bernardino within the City of Fontana's Sphere of Influence. The project proposes to construct a 1,175,720 square foot warehouse (ITE Land Use Code 150).

The project site occupies approximately 76 acres just northwest of Interstate 15, southwest of Sierra Avenue, southeast of Lytle Creek Road at the base of the lower slopes of the San Gabriel Mountains. **Exhibit 1** shows the regional location of the project site.

This analysis assumes the realignment of two portions of Lytle Creek Road. The realignment of the northeast portion of Lytle Creek Road is proposed to be constructed with the project and is included in all "With Project" scenarios. The planned realignment of the southwest portion of Lytle Creek as an extension of existing Coyote Canyon Road is assumed to be constructed at Opening Year by other parties.

The project proposes one driveway for passenger vehicles on Lytle Creek Road and one driveway for passenger cars and trucks that will connect the project to Lytle Creek Road via a public access road. **Exhibit 2** shows the proposed site plan.

2.1 STUDY AREA

A scoping agreement was reviewed and approved by City of Fontana staff prior to commencement of this analysis. The approved scoping agreement is contained in **Appendix B**. The study evaluates the following 9 intersections in the vicinity of the project site as shown in **Exhibit 3**:

1. Duncan Canyon Road / Coyote Canyon Road
2. Duncan Canyon Road / Lytle Creek Road
3. Lytle Creek Road / Project Driveway
4. Lytle Creek Road / Public Access Road
5. Sierra Avenue / Lytle Creek Road (Without Realignment)
6. Sierra Avenue / Lytle Creek Road (With Realignment)
7. Sierra Avenue / I-15 Southbound Ramps
8. Sierra Avenue / I-15 Northbound Ramps
9. Sierra Avenue / Riverside Avenue

These study locations will be analyzed in the following study scenarios:

- Existing Conditions
- Existing With Project
- Opening Year 2020 Without Project
- Opening Year 2020 With Project
- Future Year 2040 Without Project
- Future Year 2040 With Project



*** = Project Location**



Not To Scale

GENERAL NOTES:

- PROJECT SHALL BE DESIGNED TO MEET 2006 CALIFORNIA BUILDING STANDARDS CODE
- PROJECT SHALL ADHERE TO FONTANA MUNICIPAL CODE SECTION 16.04 FOR LANDSCAPE REQUIREMENTS
- PROJECT SHALL ADHERE TO FONTANA MUNICIPAL CODE SECTION 16.05 FOR SCREENING REQUIREMENTS
- PROJECT SHALL ADHERE TO CITY OF FONTANA STANDARD OF CARE FOOT CANDLE MOUNT FOR ALL ENTRANCES, BOTH PEDESTRIAN PATHS, PARKING LOTS AND ACTIVITY AREAS. ALL AREAS SHALL BE ILLUMINATED DURING ALL HOURS OF DARKNESS AND ALL LUMINAIRES UTILIZED SHALL BE HAND-RESISTANT FINISHED. LIGHTING SHALL BE FLUORESCENT, WHITE LED OR METAL HALIDE.

LEGAL DESCRIPTION (CONTINUED)

OWNER:
CAPROCK PARTNERS
2005 MAIN STREET, SUITE 240
BRINNE, CA 92514
PHONE: (949) 540-5000
FAX: (949) 340-5474

LANDSCAPE ARCHITECT:
SCOTT PETERSON, ASLA
5006 S. WILSON ROAD, STE 121
BONSALL, CA 92003
PHONE: 760.942.9900
FAX: (909) 337.8884

ARCHITECT:
DOUGLAS FRANK ARCHITECTS
4001 WESTERLY PLACE SUITE 108
INDIAPORT BEACH, CA 92680
PHONE: 949.553.2625
FAX: 949.553.0960

CIVIL ENGINEER:
COTTERREBELLY GROUP INC.
575 E. CARBON DRIVE
COLTON, CA 92534-0999
PHONE: (800) 370-4911
FAX: (809) 370-2171

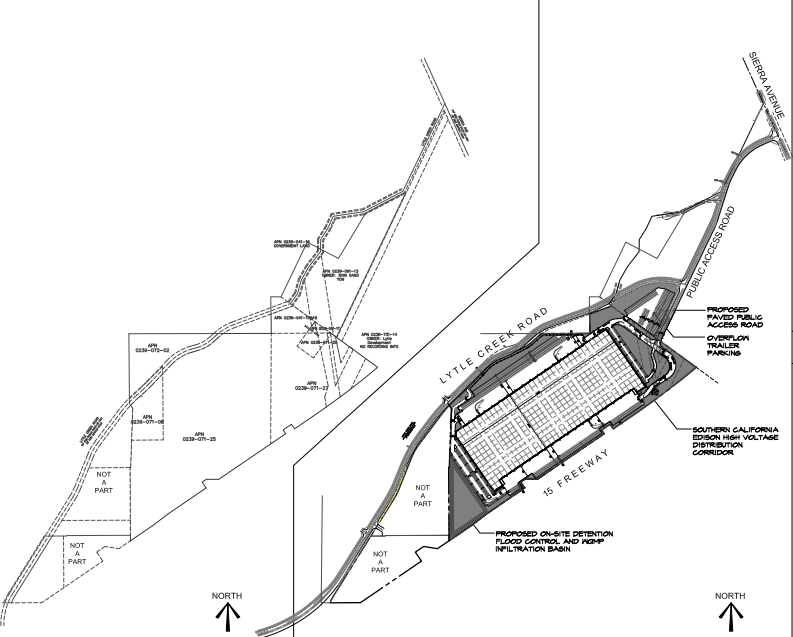

ZONING USE/OCCUPANCY:		M-2 GENERAL INDUSTRIAL WAREHOUSE (S-1) OFFICE (B)
CONSTRUCTION TYPE		V-B
CLEAR HEIGHT		36'-0"
SPRINKLERED		YES
SITE AREA:		2,884,434sf (61.17ac)
BUILDING AREA:		1,175,720sf
FAR		44.12%
PARKING REQUIRED		
OFFICE	30,000sf	1,250
WHSE	40,000sf	1,000
WHSE	1,105,720sf	14,000
TOTAL REQUIRED		16,250
PARKING PROVIDED		
AUTOMOBILE PARKING STALLS		406
TRAILER STALLS PROVIDED		309
TOTAL PROVIDED		715
DOCK DOORS PROVIDED		
LANDSCAPE REQUIRED (15%)		399,665sf
LANDSCAPE PROVIDED (23%)		627,205sf

PROJECT SUMMARY



LEGAL DESCRIPTION

PROJECT TEAM

APN MAP

MASTER SITE PLAN

VICINITY MAP

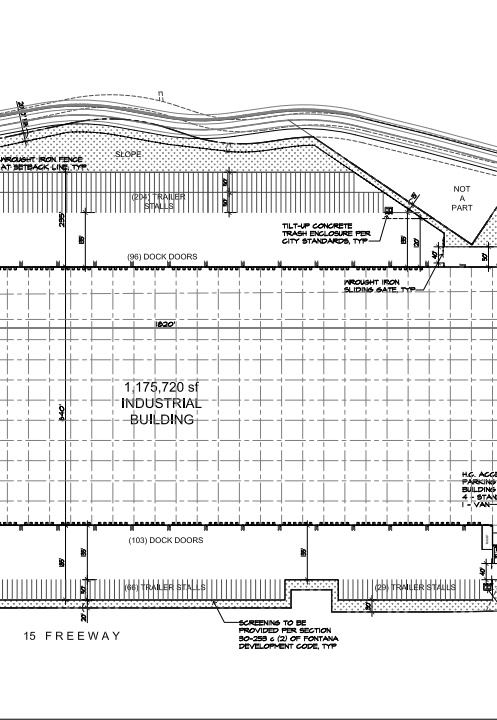
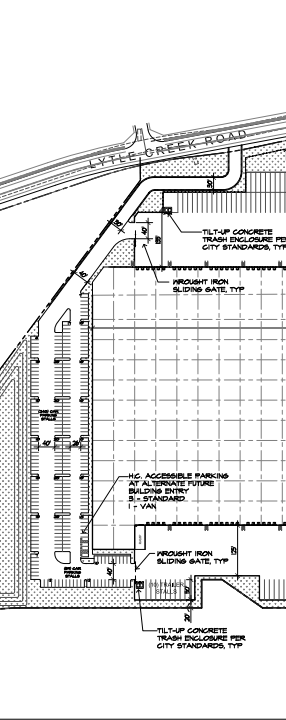
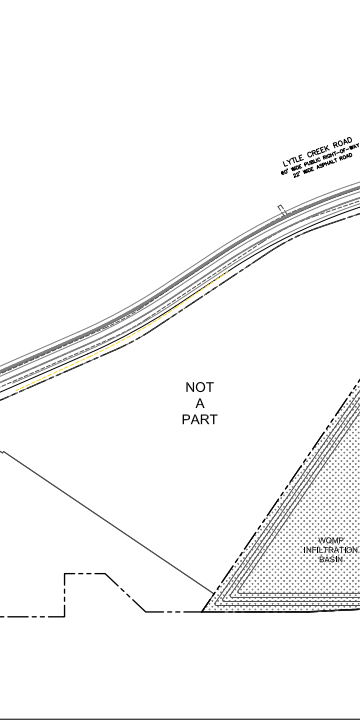
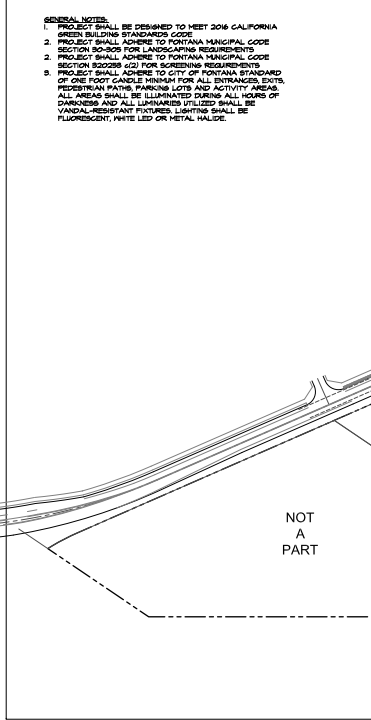

REVISIONS	2/20/2017		
PRELIMINARY SITE PLAN	DATE: 02/20/2017	SCALE: 1" = 100'-0"	DRAWN BY: DPA
	PROJECT NO: 13024.00		
	A.1		
	OPTION 15		

I-15 Logistics Center





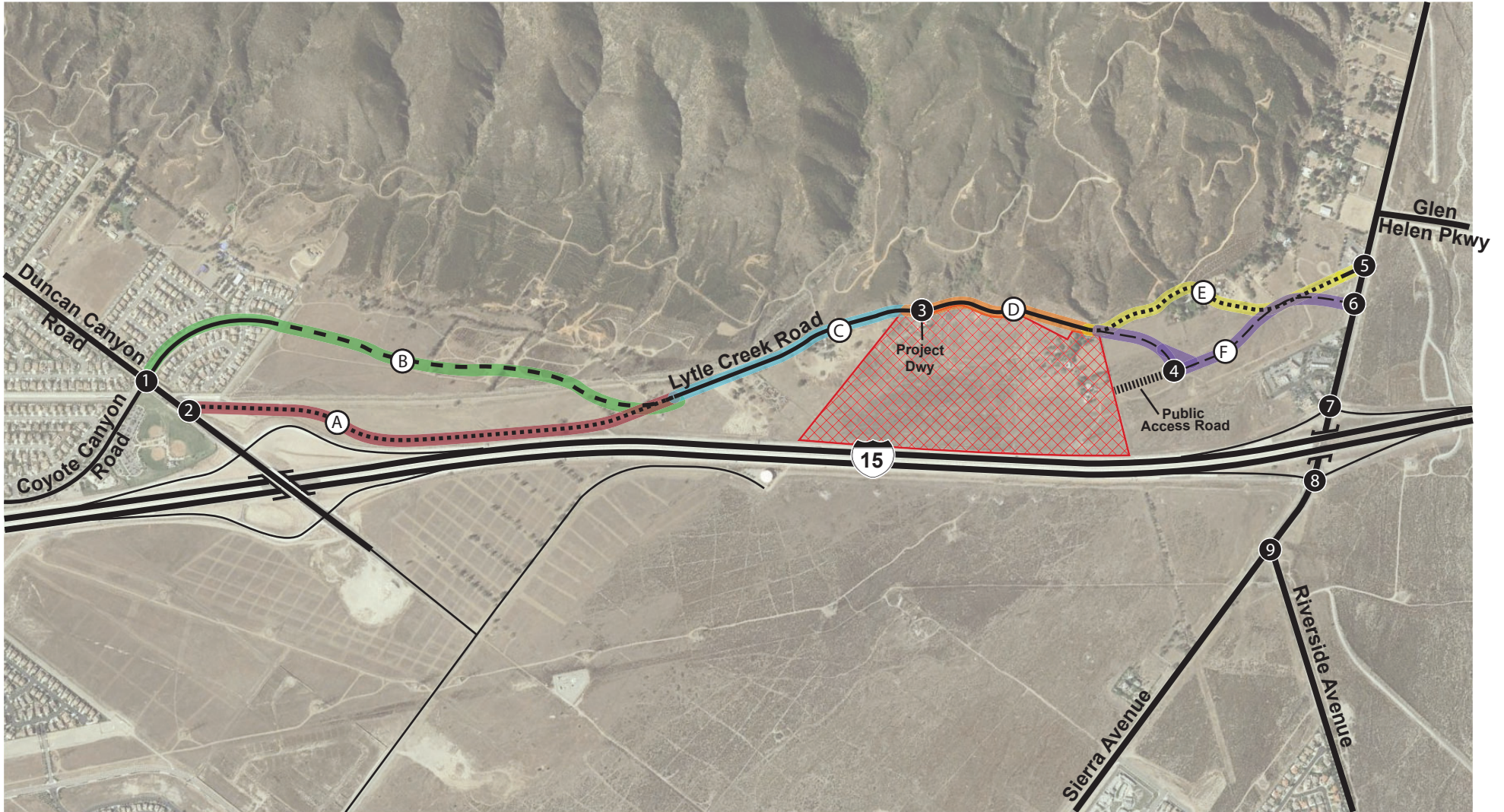

3935 Lytle Creek Road
Fontana, CA (County of San Bernardino)

1/18/18 Revised/Date: 31 March 2017

douglasfrank architects
4001 Westeryly Place, Suite 108
Indiapolis, IN 46204



Legend:

-  = Project Site (I-15 Logistics Center)
-  = Study Intersection
-  = Segments
-  = Future Proposed Roadway Realignment (By Others)
-  = Existing Lytle Creek Road (To Be Removed)
-  = Public Access Road
-  = Lytle Creek Road Realignment (Project Feature)



Not to Scale

2.2 ANALYSIS METHODOLOGY

2.2.1 Intersection Analysis Methodology

Level of Service (LOS) is commonly used as a qualitative description of intersection operation and is based on the capacity of the intersection and the volume of traffic using the intersection. The Highway Capacity Manual (HCM) 2010 analysis methodology is utilized to determine the operation LOS of the study intersections. The HCM analysis methodology describes the operation of an intersection using a range of level of service from LOS A (free-flow conditions) to LOS F (Severely congested conditions), based on the corresponding stopped delay experienced per vehicle for study intersections as shown in **Table 2**.

TABLE 2, LEVEL OF SERVICE & DELAY RANGE - INTERSECTIONS

LOS	Delay (seconds/vehicle)	
	Signalized Intersections	Un-signalized Intersections
A	≤ 10.0	≤ 10.0
B	> 10.0 to ≤ 20.0	> 10.0 to ≤ 15.0
C	> 20.0 to ≤ 35.0	> 15.0 to ≤ 25.0
D	> 35.0 to ≤ 55.0	> 25.0 to ≤ 35.0
E	> 55.0 to ≤ 80.0	> 35.0 to ≤ 50.0
F	> 80.0	> 50.0

Source: 2010 Highway Capacity Manual.

Level of service is based on the average stopped delay per vehicle for all movements of signalized intersections and all-way stop-controlled intersections; for one-way or two-way stop-controlled intersections, LOS is based on the worst stop-controlled approach.

A computer software program called *Synchro* v. 9.0 is a direct application of HCM methodology and was used to analyze the study intersections.

2.2.2 Roadway Segment Analysis Methodology

Roadway segments are evaluated by comparing average daily traffic (ADT) volumes to roadway capacity. The capacity of roadway segments are affected by a number of factors including street width, roadway segment design (i.e. geometry), number of travel lanes, number of intersection and driveways, presence of on-street parking, and traffic signal timings.

The existing daily traffic volumes were calculated based on PM peak hour intersection count data according to the following:

$$\text{Daily Traffic} = \frac{(\text{Entering Volumes} + \text{Exiting Volumes})_{\text{avg}}}{10.5\%}$$

Where volumes for adjacent intersections were used to average the encompassed street segment. A value of 10.5% was used as an approximation for the ratio of peak hour traffic to daily traffic volumes based on ITE rates for residential as well as warehouse land uses.

Roadway segment operation is described using a range of level of service from LOS A (free-flow conditions) to LOS F (severely congested conditions) based on comparing ADT to roadway capacity and utilizing the volume to capacity (V/C) ratios shown in **Table 3**.

TABLE 3, LEVEL OF SERVICE RANGES – ROADWAY SEGMENTS

LOS	V/C Ratio
A	0-0.60
B	0.61-0.70
C	0.71-0.80
D	0.81-0.90
E	0.91-1.0
F	< 1.0

*Source: City Fontana General Plan Update
Background Report, Pg. 87*

2.2.3 Freeway Segment Analysis Methodology

Caltrans Guide for the Preparation of Traffic Impact Studies, December 2002 specifies the use of the HCM Operational analysis methodology to determine level of service for freeway mainline segments. This method determines levels of service based on the volume-to-capacity (v/c) ratio as shown in **Table 4**. The resulting v/c is then compared to accepted ranges of v/c values corresponding to the various levels of service. The corresponding levels of service represents an approximation of existing or anticipated future operating conditions in the peak direction of travel during the peak hour. Traffic count data, peak hour factors, directional splits, and truck factors were obtained on Caltrans website www.dot.ca.gov. Traffic count data from Year 2016 was the latest available data found on Caltrans website and used in this analysis. Truck traffic, represented as a percentage of total traffic, has been utilized for the purposes of this analysis in an effort to not overstate traffic volumes. As such, actual vehicles (as opposed to passenger-car-equivalent volumes) have been utilized for the purpose of this analysis.

TABLE 4, LEVEL OF SERVICE CRITERIA – FREEWAY SEGMENTS

LOS	Volume to Capacity (V/C) Ratio
A	≤ 0.30
B	> 0.30 to ≤ 0.50
C	> 0.50 to ≤ 0.71
D	> 0.71 to ≤ 0.89
E	> 0.89 to ≤ 1.00
F	> 1.00

Source: Caltrans Guide for the Preparation of TIA

2.2.4 Freeway Merge/Diverge Analysis Methodology

The merge/diverge analysis is based on the HCM Ramps and Ramps Junctions analysis method and performed using Highway Capacity Software (HCS+). The measure of effectiveness (reported in passenger cars per mile per lane) are calculated based on the existing number of travel lanes, number of lanes at the on and off ramps both at the analysis junction and at upstream and downstream locations (if applicable) and acceleration/deceleration lengths at each merge/diverge point. For trucks, the merge/diverge analysis used actual vehicles (non-PCE) to avoid overstating traffic volumes on the ramps. **Table 5** presents the merge/diverge area level of service for each density range utilized for this analysis.

TABLE 5, LEVEL OF SERVICE CRITERIA – RAMP & RAMP JUNCTIONS

LOS	Density (pc/mi/ln)
A	≤ 10
B	> 10 to ≤ 20
C	> 20 to ≤ 28
D	> 28 to ≤ 35
E	> 35
F	Demand Exceeds Capacity

Source: 2010 Highway Capacity Manual

2.3 THRESHOLDS OF SIGNIFICANCE

The City of Fontana General Plan recommends a level of service standard of LOS “C” or better as acceptable operating conditions for intersections and roadway segments.

In accordance with *City of Fontana Traffic Impact Analysis Guidelines*, the determination of significant impacts are based on the increase in delay caused by the addition of project related traffic at study intersections that exceeds the allowable thresholds identified in **Table 6**. Thus, impacts are identified at intersections within the City’s jurisdiction where the LOS C standard is not met and the change in delay shown in **Table 6** occurs under the “With Project” conditions.

TABLE 6, THRESHOLDS OF SIGNIFICANT IMPACTS - INTERSECTIONS

With Project LOS	Significant Impact Thresholds
A/B	10 Seconds
C	8.0 Seconds
D	5.0 Seconds
E	2.0 Seconds
F	1.0 Seconds

Source: City Fontana Draft TIA Guidelines, Table XYZ

The City of Fontana has not established any significant impact criteria for roadway segments. For this analysis, it is assumed that a significant impact occurs when a roadway segment deteriorates from acceptable level of service (LOS "C" or better) to unacceptable level of service (LOS "D" or worse) or if the project contributes to an existing deficiency.

Caltrans endeavors to maintain a target LOS at the transition between LOS C and LOS D on State Highway facilities, however, Caltrans acknowledges that this may not always be feasible and recommends that the lead agency consult with Caltrans to determine the appropriate target LOS. If an existing facility is operating at less than the appropriate target LOS, the existing LOS should be maintained. For purposes of this analysis, LOS D is considered acceptable at Caltrans facilities including the signalized intersections at the freeway ramps at Sierra Avenue, the freeway on and off ramps and freeway mainline segments. For purposes of this analysis, a significant impact occurs when project-related traffic causes a freeway ramp or freeway mainline segment to deteriorate from an acceptable LOS (D or better) to a deficient LOS (E or F) or if the project contributes to an existing deficiency.

3 EXISTING CONDITIONS

3.1 SURROUNDING ROADWAY NETWORK

The characteristics of the roadway system in the vicinity of the project site are described below:

Sierra Avenue is a two- to four-lane roadway oriented in the north-south direction. Between Lytle Creek Road and the I-15 Southbound Ramps, Sierra Avenue is four lanes with a two-way-left-turn-lane; from the I-15 Southbound Ramps to the I-15 Northbound Ramps, it is undivided with four lanes; from the Northbound Ramps to Riverside Avenue, it is four lanes with a striped median; south of Riverside Avenue it is undivided with two lanes. The ultimate classification of Sierra Avenue is a Primary Highway north of the I-15 Northbound Ramps and Major Highway south of the I-15 Northbound Ramps. Bicycle and pedestrian facilities are not provided within the study area. The posted speed limit is 55 mph within the study area.

Duncan Canyon Road is a four-lane divided roadway oriented in the east-west direction within the study area with a raised median. East of the I-15 Northbound Ramps, Duncan Canyon Road narrows to two lanes and terminates at Citrus Avenue. Future improvements will connect Duncan Canyon Road to Sierra Avenue to the east. The ultimate classification of Duncan Canyon Road is a Primary Highway west of the I-15 Southbound Ramps as well as east of Lytle Creek Road South and is classified as a Major Highway between the I-15 Northbound Ramps and Lytle Creek Road South. The posted speed limit is 45 mph within the study area. Class II bike lanes and pedestrian sidewalks are provided on both sides of the street.

Lytle Creek Road is a two-lane undivided roadway oriented in the north-south direction. Bicycle and pedestrian facilities are not provided within the study area. The ultimate classification of Lytle Creek Road is a Secondary Highway. It should be noted that the existing southwest portion of Lytle Creek Road is planned to be realigned as an extension of existing Coyote Canyon Road by project opening year and is to be constructed by other parties. In addition, the realignment of the northeast portion of Lytle Creek Road is proposed to be constructed with the proposed project.

3.2 EXISTING CITY OF FONTANA CIRCULATION PLAN

Exhibit 4 shows the current City of Fontana General Plan Circulation Element Roadway System. This shows the classification and configuration of arterial highways planned to serve the ultimate development defined by the land use element of the General Plan.

According to the City's General Plan Circulation Element, Lytle Creek Road is classified as a four-lane Secondary Highway. Urban Crossroads completed an analysis in 2015 assessing the reclassification of Lytle Creek Road, from Sierra Avenue to Project's western boundary from a four lane Secondary Highway as currently designated to a two-lane undivided roadway. The analysis performed by Urban Crossroads indicated that no capacity issues are anticipated due to the proposed re-classification of Lytle Creek Road from Sierra Avenue to Project's western boundary. As part of the Project's requested entitlements, the Project proposes to obtain a General Plan amendment to reclassify Lytle Creek Road as a two-lane Collector. Therefore, this analysis evaluated Lytle Creek Road from Sierra Avenue to Project's western boundary as a two-lane Collector. The analysis results for the roadway segments along Lytle Creek Road is provided in subsequent sections of this report.

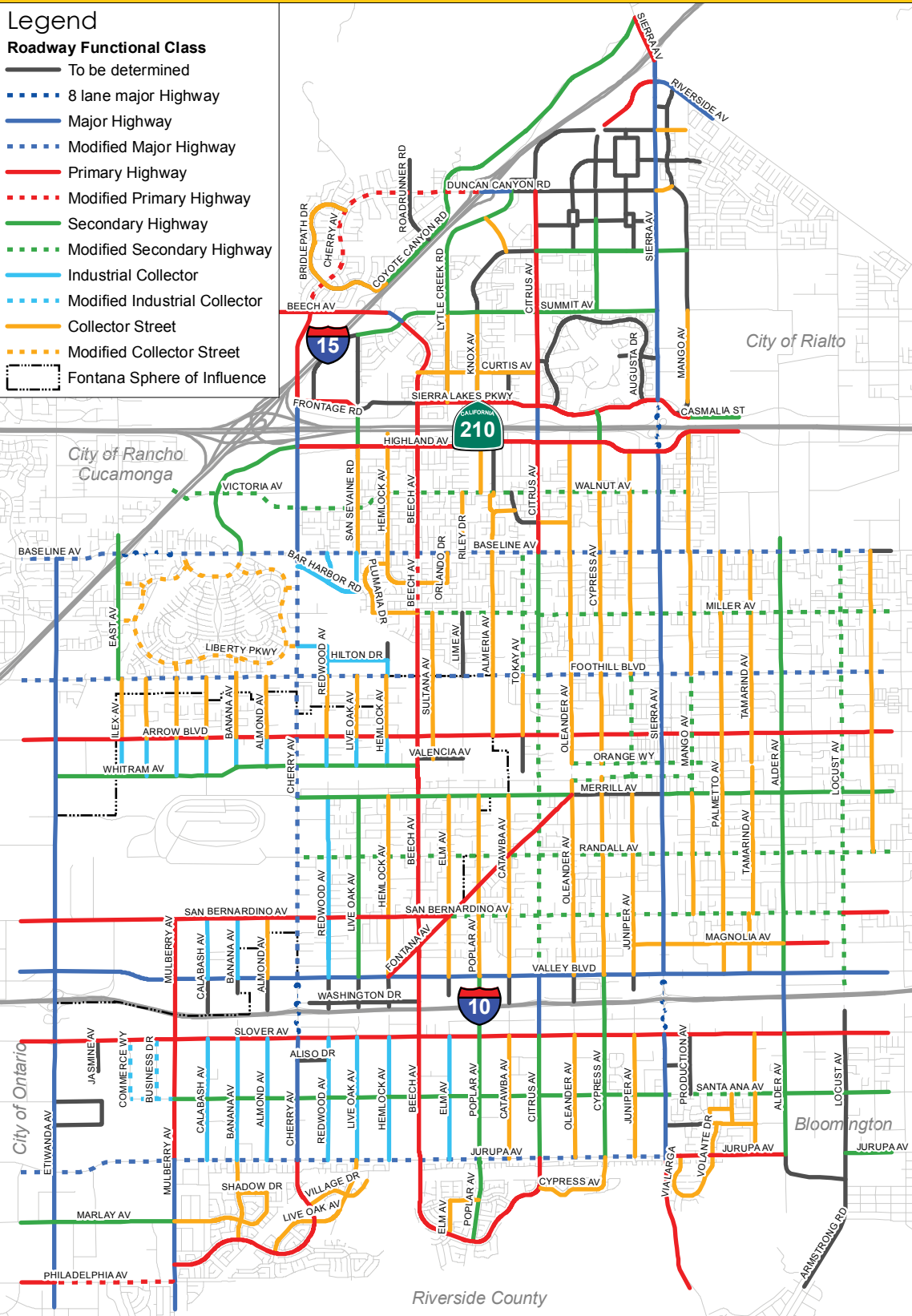

Roadway Functional Classifications
 March, 2017
 Data source: City of Fontana, 2017

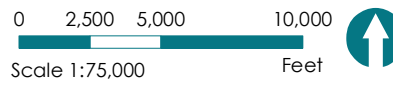

City of Fontana Circulation Element Roadway Functional Classification

3.3 EXISTING CONDITIONS TRAFFIC VOLUMES

To determine the existing operations of the study intersections, AM peak hour and PM peak hour intersection movement counts were collected on Wednesday, January 24, 2018. AM peak period intersections counts were collected from 7:00 AM to 9:00 AM and PM peak period counts were collected from 4:00 PM to 6:00 PM. The counts used in this analysis were taken from the highest hour within the peak period counted. These counts were axle-specific and identified passenger cars, 2-axle trucks, 3-axle trucks, and 4+ axle trucks.

In order to account for truck traffic in the area, these raw volumes were converted to passenger car equivalents (PCE) in accordance with the *City of Fontana Traffic Impact Analysis Guidelines*. The following factors were used to convert truck trips to PCE's:

- 2-axle trucks = 2.0 PCE
- 3-axle trucks = 2.5 PCE
- 4+ axle trucks = 3.0 PCE

Detailed traffic count data is contained in **Appendix A**.

Exhibit 5 shows the Existing conditions study intersection lane geometry. **Exhibit 6** shows the AM and PM peak hour volumes in PCE at the study intersections.

3.4 EXISTING CONDITIONS PEAK HOUR STUDY INTERSECTION LOS

Table 7 summarizes existing conditions AM and PM peak hour level of service for all study intersections. Detailed analysis sheets are contained in **Appendix C**.

TABLE 7, EXISTING CONDITIONS AM/PM PEAK HOUR INTERSECTION LOS

Study Intersection	Traffic Control	Existing Conditions	
		AM Delay ¹ - LOS	PM Delay ¹ - LOS
1 - Coyote Canyon Rd / Duncan Canyon Rd	TWSC	Not Studied Without Lytle Creek Road Realignment	
2 - Lytle Creek Rd / Duncan Canyon Rd	OWSC	8.7 - A	9.6 - A
3 - Project Dwy / Lytle Creek Rd	OWSC	Does Not Exist Without Project	
4 - Lytle Creek Rd / Public Access Rd	OWSC	Does Not Exist Without Project	
5 - Sierra Ave / Lytle Creek Rd (W/o Realignment)	OWSC	17.4 - C	12.6 - B
6 - Sierra Ave / Lytle Creek Rd (W/ Realignment)	OWSC	Does Not Exist Without Project	
7 - Sierra Ave / I-15 SB Ramps	Signal	> 80.0 - F	12.5 - B
8 - Sierra Ave / I-15 NB Ramps	Signal	11.6 - B	22.8 - C
9 - Sierra Ave / Riverside Ave	AWSC	60.8 - F	> 80.0 - F

Note: Deficient intersection operation indicated in **bold**.

¹ Average seconds of delay per vehicle.

LOS = level of service.

DNE = Does Not Exist.

TWSC = Two-Way Stop Control

OWSC = One-Way Stop Control

AWSC = All-Way Stop Control

As shown in **Table 7**, all study intersections are currently operating at an acceptable level of service (LOS C or better) with the exception of the following:

- Sierra Avenue / I-15 Southbound Ramps (LOS F in AM peak hour)
- Sierra Avenue / Riverside Avenue (LOS F in AM & PM peak hour)

3.5 EXISTING CONDITIONS ROADWAY SEGMENT LOS

A roadway segment level of service analysis was conducted using the methodologies discussed previously.

Table 8 presents the results of the existing conditions roadway segment level of service analysis. The roadway segment IDs (A through F) as shown graphically on **Exhibit 3**. As shown, all of the roadway segments currently operate at acceptable levels of service (C or better) based on daily capacity thresholds.

TABLE 8, EXISTING CONDITIONS ROADWAY SEGMENT LOS

Segment	Location	Roadway Alignment	No. Lanes	LOS E Capacity ¹	Existing		
					ADT	V/C	LOS
Lytle Creek Road	Duncan Canyon Rd. to Proposed Realignment Diverge Point (West)	A Existing	2	12,000	180	0.02	A
		B Proposed	4	-	-	-	-
	Proposed Realignment Diverge Point (West) to Proposed Project Dwy.	C Existing	2	12,000	400	0.03	A
	Proposed Project Dwy. To Proposed Realignment Diverge Point (East)	D Existing	2	12,000	400	0.03	A
	Proposed Realignment Diverge Point (East) to Sierra Avenue	E Existing	2	12,000	610	0.05	A
		F Proposed	2	-	-	-	-

¹Source: City of Fontana General Plan Circulation Element Appendix C; Table A

ADT= Average Daily Traffic

LOS= Level of Service

V/C= Volume to Capacity Ratio

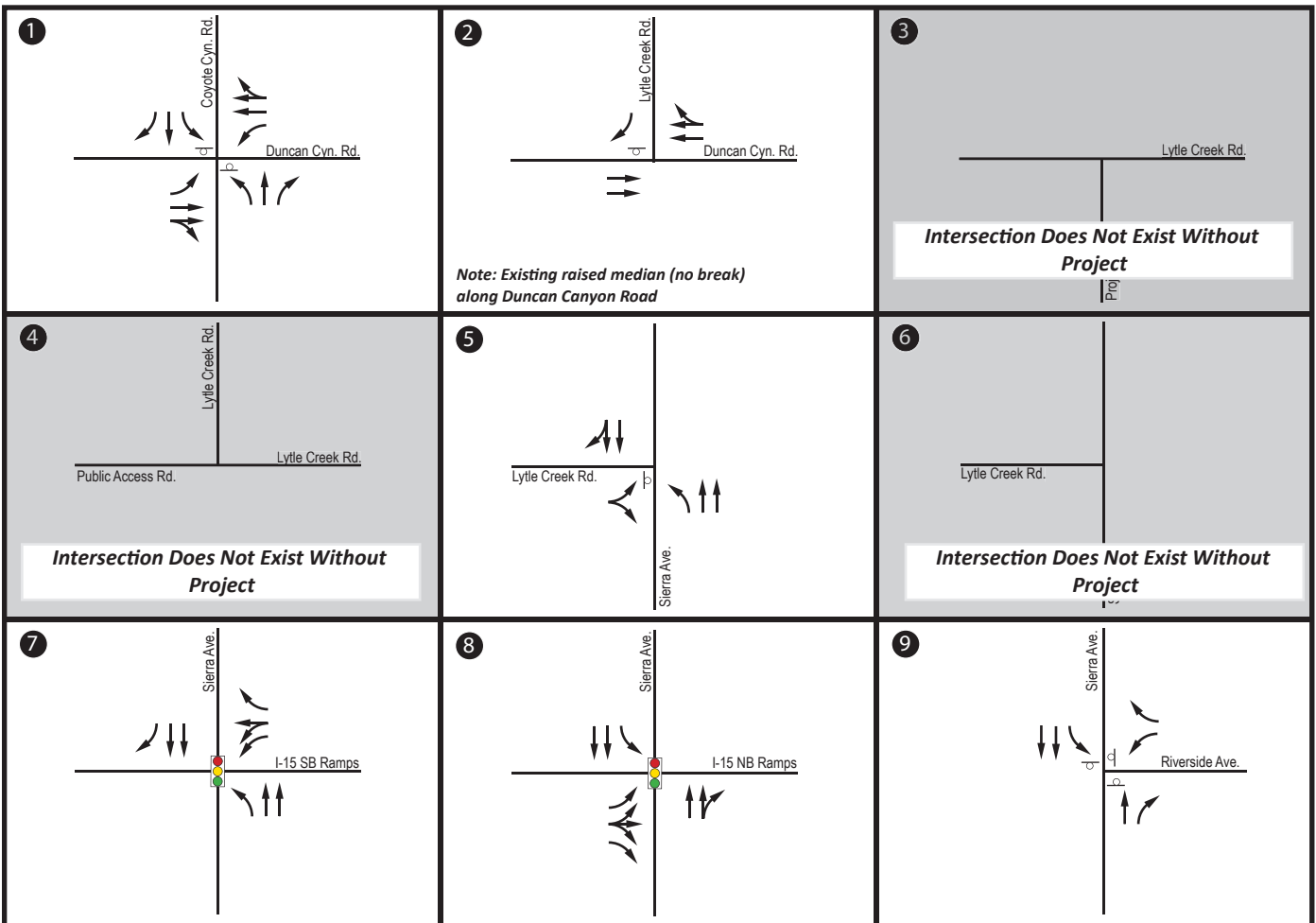

Legend:

- = Project Site (I-15 Logistics Center)
- = Signal Control
- = Study Intersection
- = Existing Lytle Creek Road
- = Stop Control

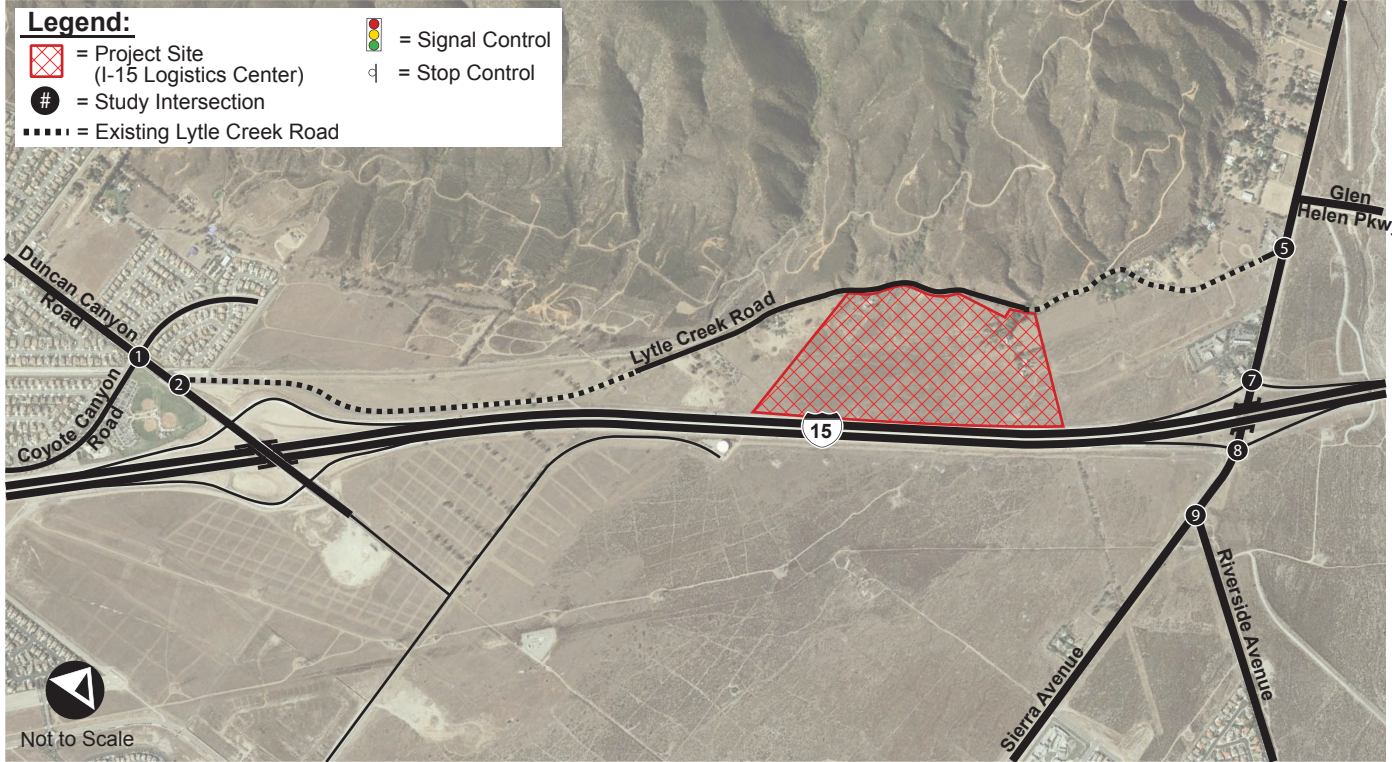

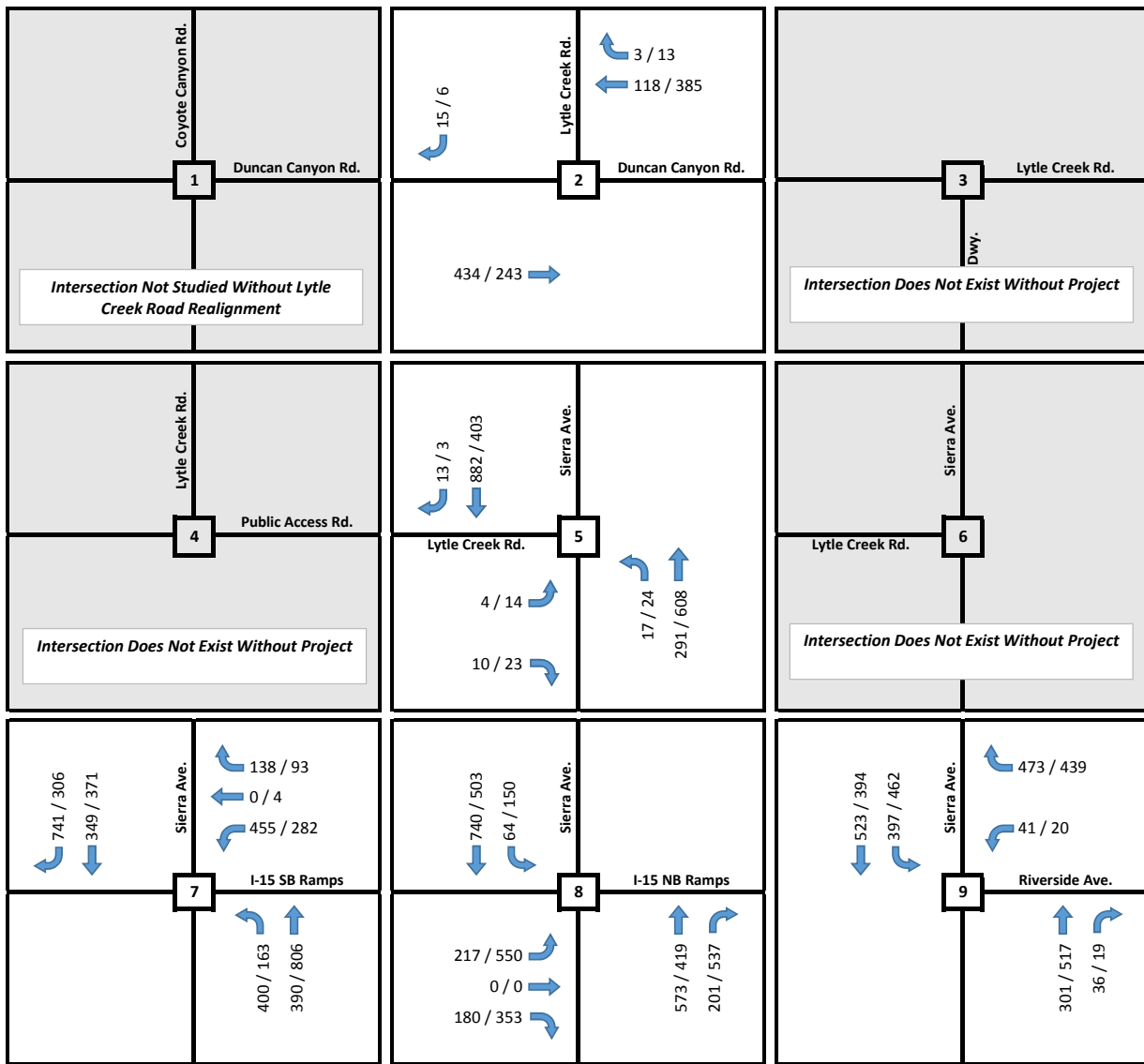

Notes: XX / XX = AM / PM Peak Hour Volumes in PCE's
 ### = Estimated Daily Traffic Volumes

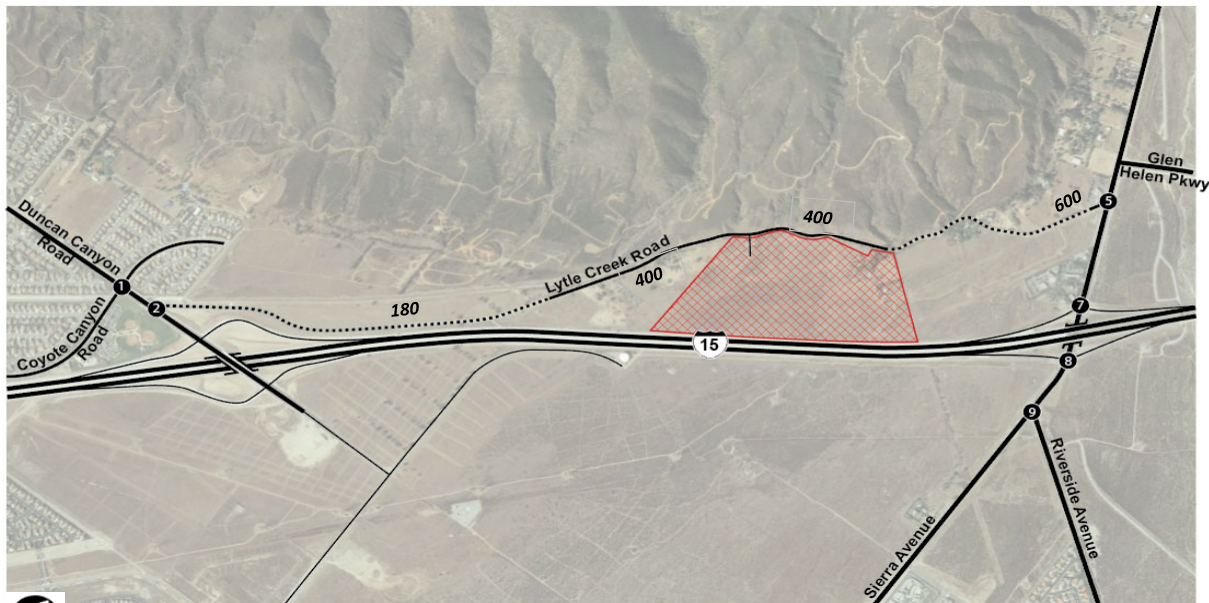

4 PROPOSED PROJECT

The project proposes to construct a 1,175,720 square-foot warehouse (ITE Land Use Code 150). The project site occupies approximately 75.76 acres southeast of Lytle Creek Road between Duncan Canyon Road and Sierra Avenue. The site will have 2 points of vehicular access; the driveway located on Lytle Creek Road will be utilized by passenger cars only to access the parking on the west side of the project site; the proposed public access road will be utilized by passenger cars and trucks to allow access to parking and docking areas. **Exhibit 2** shows the project site plan.

The proposed project will realign approximately 0.42 miles of Lytle Creek Road from the project's northern boundary to Sierra Avenue. The existing Lytle Creek Road will be realigned to meet with the proposed public access road at a 90-degree angle. This new intersection will have a minor street stop control on the realigned Lytle Creek Road with the through movements providing direct access to the project site without the need for heavy trucks that are entering and exiting the site to stop. The newly constructed road will continue for approximately 2,200 feet and connect the public access road to Sierra Avenue at a 90-degree angle. The need for a signalized intersection at this location has been analyzed as part of this traffic study.

This proposed northeast partial realignment has been assumed in all "With Project" scenarios.

4.1 PROJECT FORECAST TRIP GENERATION

In order to calculate vehicle trips forecast to be generated by the proposed project, the *Institute of Transportation Engineers (ITE) 10th Edition Trip Generation Manual* trip generation rates were utilized. **Table 9** summarizes the ITE trip generation rates (ITE Land Use Code 150) used as well as the breakdown by vehicle type (passenger car, 2-axle trucks, 3-axle trucks, and 4+ axle trucks) according to the *South Coast Air Quality Management District (SCAQMD)*. The assumed 31% of truck trips and 69% of passenger car trips is based on the *High-Cube Warehouse Vehicle Trip Generation Analysis* prepared by Institute of Transportation Engineers, Washington DC dated October 2016.

TABLE 9, ITE TRIP GENERATION RATES

Vehicle Type Breakdown ¹		Daily Trip Rate ²	AM Peak Hour ²		PM Peak Hour ²	
			Rate	In : Out	Rate	In : Out
Passenger Car	69.00%	1.201 / KSF	0.117	77% : 23%	0.131	27% : 73%
2 Axle Truck	6.80%	0.118 / KSF	0.012		0.013	
3 Axle Truck	5.50%	0.096 / KSF	0.009		0.010	
4+ Axle Truck	18.70%	0.325 / KSF	0.032		0.036	
Total Trucks	31.00%	0.539 / KSF	0.053		0.059	
Total	100%	1.74 / KSF	0.17	77% : 23%	0.19	27% : 73%

Notes:

KSF= Thousand Square Feet

¹Source: SCAQMD

²Source: ITE Trip Generation Manual, 10th edition. Land Use Code: 150

Table 10 shows the vehicular trip generation forecast to be generated by the proposed project utilizing the ITE trip generation rates shown in **Table 9**. **Table 10** also shows the conversion of vehicle trips to passenger car equivalents (PCE's) after the following factors were applied to account for truck activity:

- 2-axle trucks = 2.0 PCE
- 3-axle trucks = 2.5 PCE
- 4+ axle trucks = 3.0 PCE

TABLE 10, PROPOSED PROJECT TRIP GENERATION IN VEHICLES

Warehouse (ITE 150)		Daily Trips	AM Peak Hour			PM Peak Hour			
Vehicle Type Breakdown ¹	Intensity		Volume	Inbound	Outbound	Volume	Inbound	Outbound	
Passenger Car	69.00%	1,175.72 KSF	1,412	138	106	32	154	42	112
2 Axle Truck	6.8%		139	14	11	3	15	4	11
3 Axle Truck	5.5%		113	11	8	3	12	3	9
4+ Axle Truck	18.7%		383	37	28	9	42	11	31
Total Trucks	31.0%		634	62	48	14	69	19	50
Total	100.0%		2,046	200	154	46	223	60	163

Warehouse (ITE 150)		Daily Trips	AM Peak Hour			PM Peak Hour			
Vehicle Type Breakdown ¹	PCE ²		Volume	Inbound	Outbound	Volume	Inbound	Outbound	
Passenger Car	69.0%	1.0	1,412	138	106	32	154	42	112
2 Axle Truck	6.8%	2.0	278	28	22	6	30	8	22
3 Axle Truck	5.5%	2.5	283	28	20	8	30	7	23
4+ Axle Truck	18.7%	3.0	1,149	111	84	27	126	33	93
Total Trucks	31.0%		1,710	167	126	41	186	48	138
Total	100.0%		3,122	305	232	73	340	90	250

Notes:

¹Source: SCAQMD

²PCE=Passenger Car Equivalents - Source: City of Fontana TIA Guidelines

As shown in **Table 10**, the proposed project is forecast to generate 3,122 daily PCE trips with 305 PCE trips occurring during the AM peak hour (232 in / 73 out) and 340 PCE trips occurring during the PM peak hour (90 in / 250 out).

4.2 TRIP DISTRIBUTION AND TRIP ASSIGNMENT OF PROPOSED PROJECT

Exhibit 7 shows the project's forecast trip distribution of cars and **Exhibit 8** shows the project's forecast trip distribution of trucks.

Exhibit 9 shows the corresponding forecast assignment of AM and PM peak hour project-generated trips assuming the trip percent distribution shown for cars and trucks. All trips are shown as PCE's.

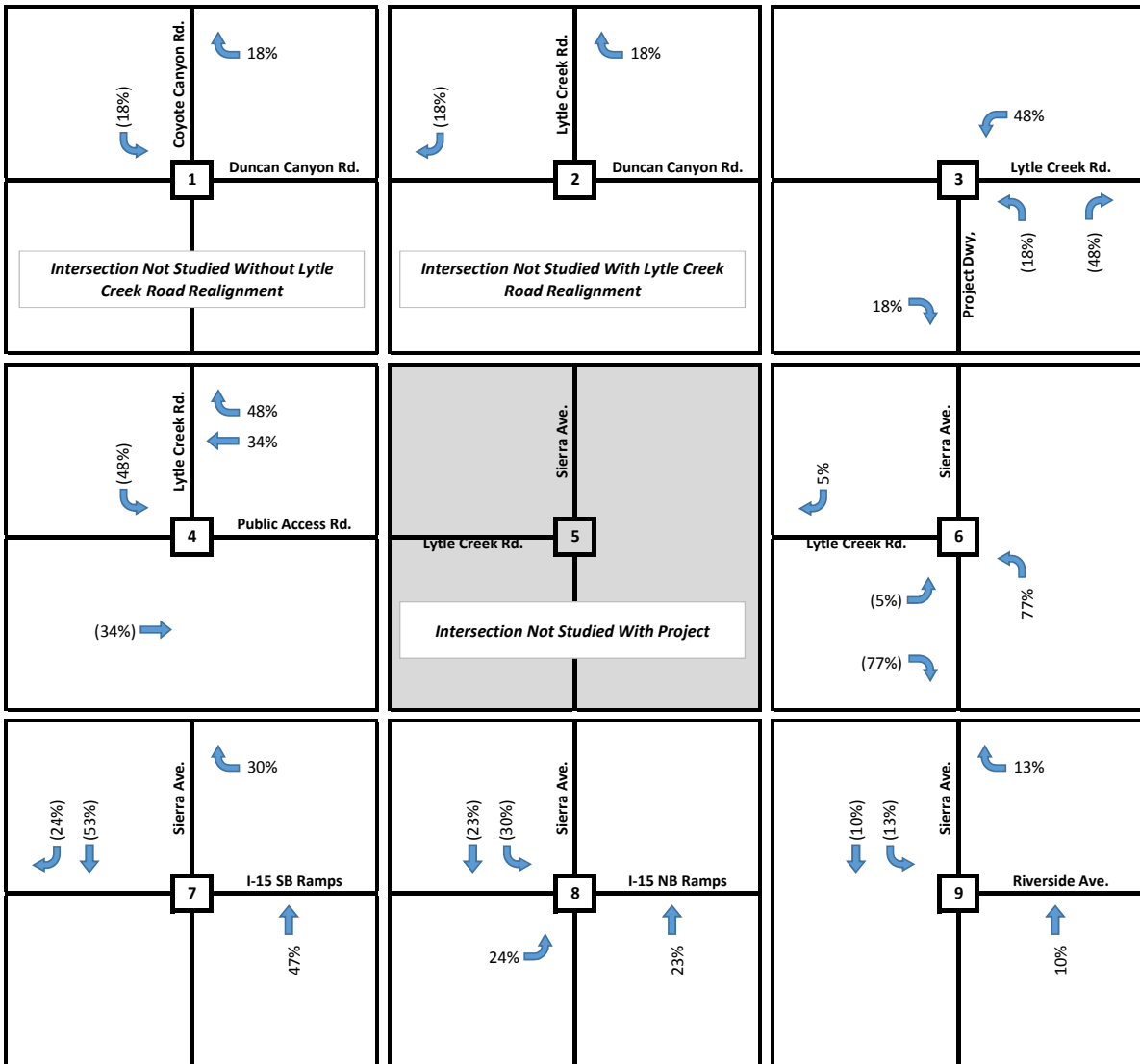

Notes:

XX% = Inbound Distribution Percentage

(XX%) = Outbound Distribution Percentage



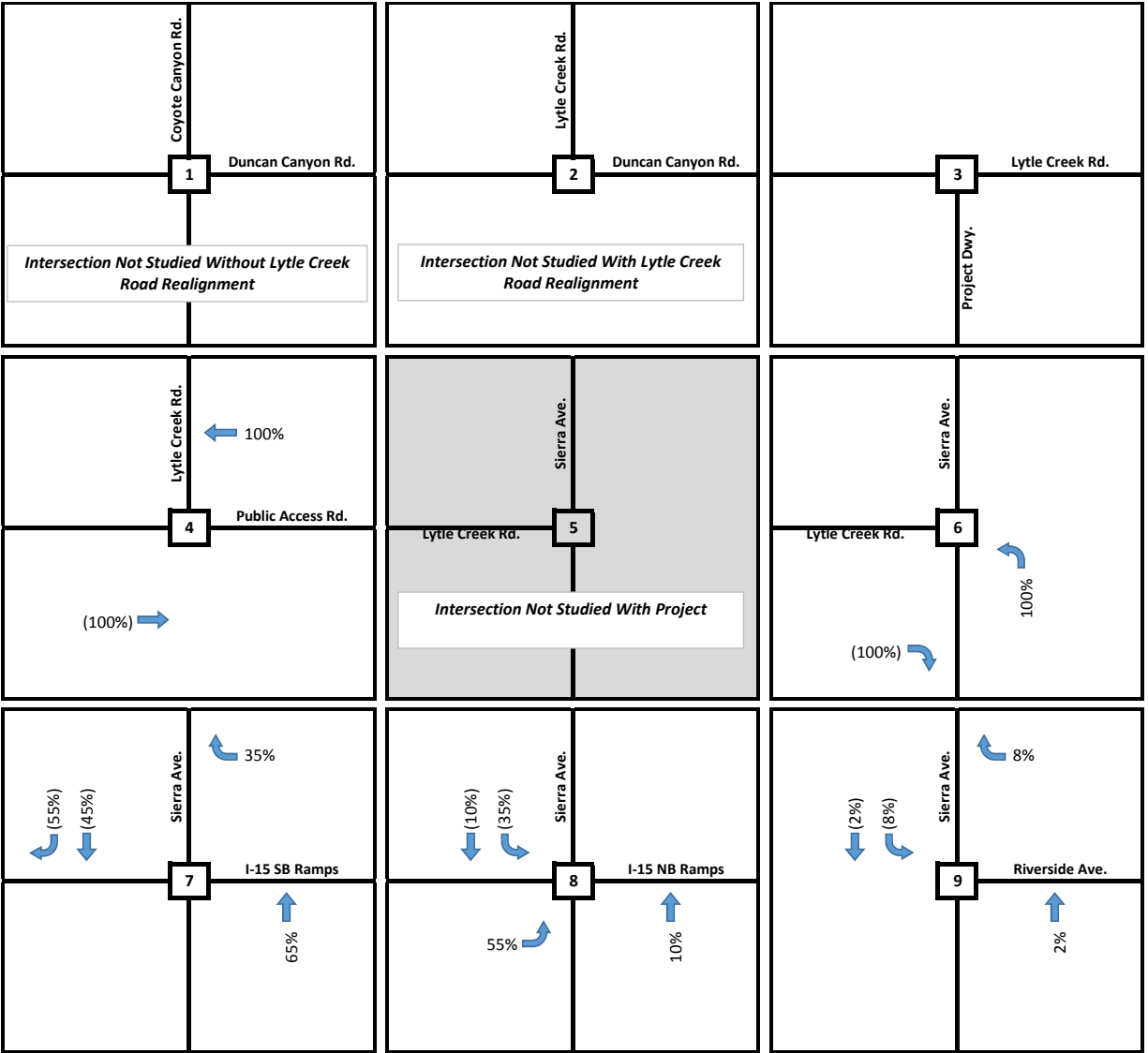

Notes:

XX% = Inbound Distribution Percentage

(XX%) = Outbound Distribution Percentage



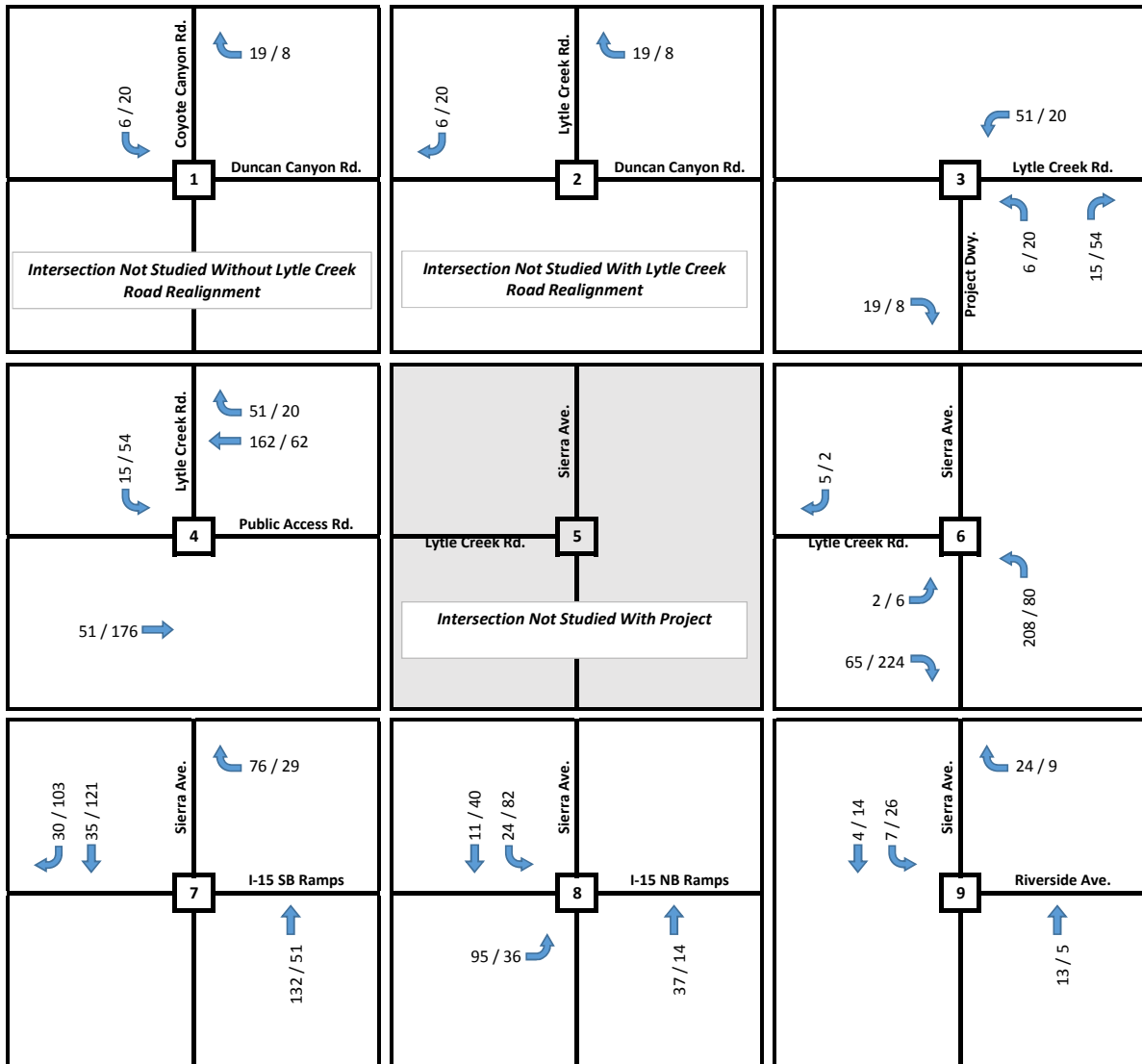

Notes: XX / XX = AM / PM Peak Hour Volumes in PCE's
 ### = Estimated Daily Traffic Volumes



5 EXISTING WITH PROJECT CONDITIONS

5.1 EXISTING WITH PROJECT CONDITIONS TRAFFIC VOLUMES

Existing With Project conditions traffic volumes are derived by adding trips forecast to be generated by the proposed project to existing conditions traffic volumes. **Exhibit 10** shows the forecast Existing With Project conditions AM and PM peak hour and daily volumes at study intersections.

The project proposes to realign and construct a new Lytle Creek Road from the property's northern boundary to Sierra Avenue (approx. 0.42 miles) as illustrated in **Exhibit 3**. The existing northern alignment of Lytle Creek Road east of the project would be removed following completion of the new roadway referred to as the Public Access Road in this report. It should be noted the project is responsible for constructing a new traffic signal at Sierra Avenue / Lytle Creek Road (Int. #6) with the proposed realignment. A traffic signal was determined to be warranted in the Lytle Creek Road Alignment Study (May 31, 2016) and therefore, a signal is assumed to be installed as part of the road realignment.

West of the project site, Lytle Creek Road currently connects to Duncan Canyon Road which is the southerly alignment illustrated in **Exhibit 3**. For Existing With Project conditions, project-related traffic is assumed to use the existing Lytle Creek Road. Since project traffic heading west on Lytle Creek Road distributes south towards the I-15/Duncan Canyon Road interchange, there is no project traffic at the intersection of Coyote Canyon Road / Duncan Canyon Road and therefore not studied under the Existing With Project condition.

The Monarch Hills Project was approved by the Fontana City Council on February 26, 2019 (second reading occurring March 12, 2019). As part of that project, Lytle Creek Road would be realigned to intersect with Coyote Canyon Road. Under Opening Year 2020 conditions, the analysis the new alignment of Lytle Creek Road west of the project site. Additional information related to the planned southwest realignment of Lytle Creek Road is discussed in the following section of this report.

5.2 EXISTING WITH PROJECT CONDITIONS PEAK HOUR STUDY INTERSECTION LOS

Exhibit 11 shows the Existing With Project lane configurations. **Table 11** summarizes Existing With Project conditions AM and PM peak hour level of service for all study intersections. Detailed analysis sheets are contained in **Appendix D**.

As shown in **Table 11**, all study intersections are forecast to operate at an acceptable level of service (LOS C or better) during the peak hours with the addition of project-related traffic to existing traffic volumes with the exception of the following intersection:

- Sierra Avenue / I-15 Southbound Ramps (LOS F in the AM peak hour)
- Sierra Avenue / Riverside Avenue (LOS F in the AM and PM peak hour)

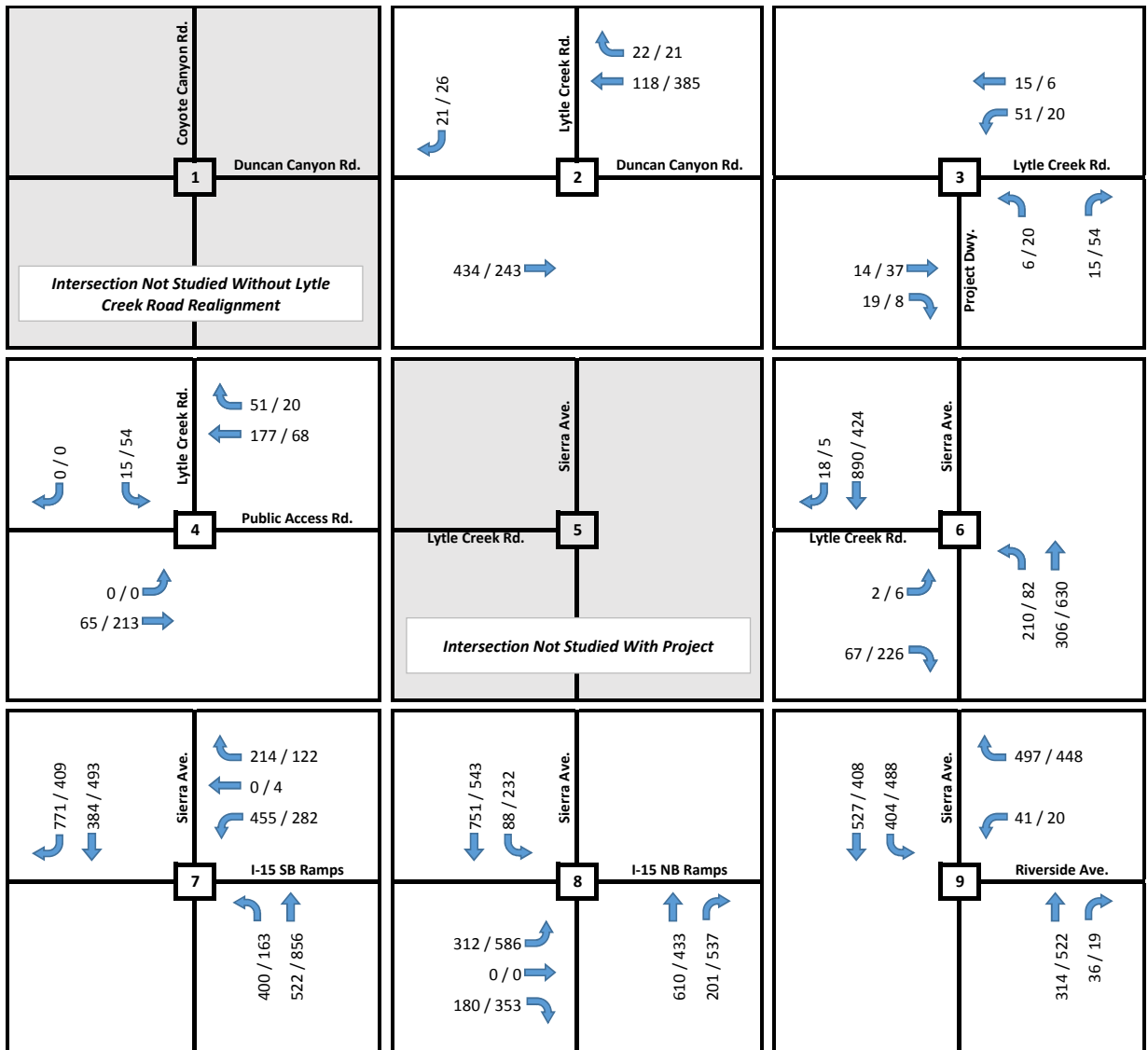

Notes: XX / XX = AM / PM Peak Hour Volumes in PCE's
 ### = Estimated Daily Traffic Volumes



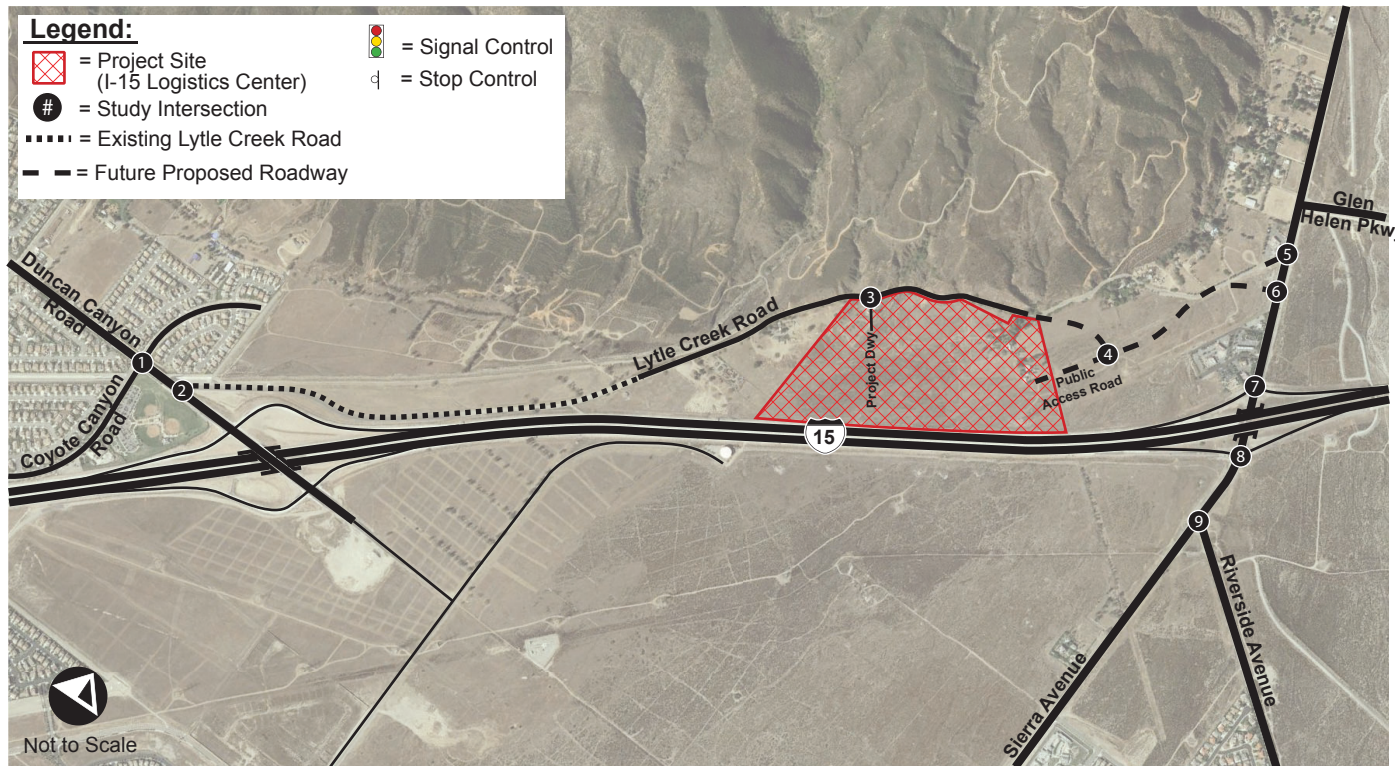
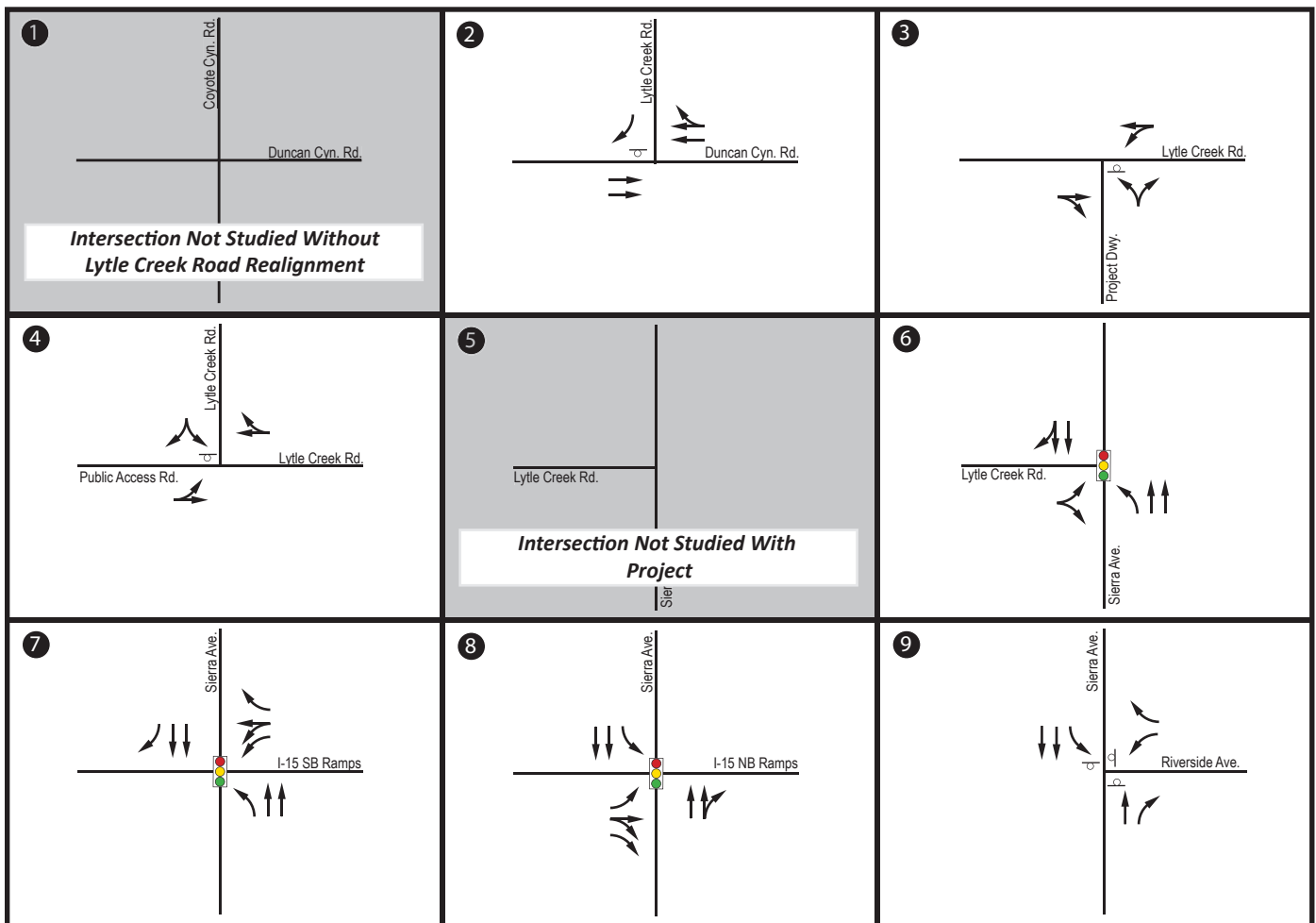

**TABLE 11, EXISTING WITH PROJECT CONDITIONS
AM/PM PEAK HOUR INTERSECTION LOS**

Study Intersection	Traffic Control	Existing Conditions		Existing With Project Conditions		Change in Delay (sec.)		Significant Impact?	
		AM Delay ¹ - LOS	PM Delay ¹ - LOS	AM Delay ¹ - LOS	PM Delay ¹ - LOS	AM	PM	AM	PM
		1 - Coyote Canyon Rd / Duncan Canyon Rd	TWSC	Not Studied Without Lytle Creek Road Realignment				—	—
2 - Lytle Creek Rd / Duncan Canyon Rd	OWSC	8.7 - A	9.6 - A	8.8 - A	9.8 - A	0.1	0.2	No	No
3 - Project Dwy / Lytle Creek Rd	OWSC	Does Not Exist Without Project		8.8 - A	8.9 - A	—	—	No	No
4 - Lytle Creek Rd / Public Access Rd	OWSC	Does Not Exist Without Project		10.2 - B	10.7 - B	—	—	No	No
5 - Sierra Ave / Lytle Creek Rd (W/o Realignment)	OWSC	17.4 - C	12.6 - B	Not Studied with Project		—	—	No	No
6 - Sierra Ave / Lytle Creek Rd (W/ Realignment) ²	Signal	Does Not Exist Without Project		17.2 - B	11.0 - B	—	—	No	No
7 - Sierra Ave / I-15 SB Ramps	Signal	> 80.0 - F	12.5 - B	> 80.0 - F	12.8 - B	0.9	0.3	No	No
8 - Sierra Ave / I-15 NB Ramps	Signal	11.6 - B	22.8 - C	15.6 - B	30.4 - C	4.0	7.6	No	No
9 - Sierra Ave / Riverside Ave	AWSC	60.8 - F	> 80.0 - F	70.3 - F	> 80.0 - F	9.5	9.7	YES	YES

Note: Deficient intersection operation indicated in **bold**.

TWSC = Two-Way Stop Control LOS = Level of Service

¹ Seconds of delay per vehicle.

OWSC = One-Way Stop Control AWSC = All-Way Stop Control

² A traffic signal was determined to be warranted per the Lytle Creek Road Alignment Study (May 31, 2016), thus a traffic signal is assumed with the road realignment.

According to the *City of Fontana Traffic Impact Analysis Guidelines* significance criteria, the following intersections result in a direct significant impact as a result of the proposed project and therefore, mitigation is required:

- Sierra Avenue / Riverside Avenue (AM and PM peak hour)

The following mitigation measures are recommended to mitigate the intersection impacts.

Mitigation Measure #1: Sierra Avenue / Riverside Avenue

The City of Fontana is planning to construct an additional northbound through lane on Sierra Avenue and install a new traffic signal. The proposed improvements at this location are expected to improve the operations of the intersection to an acceptable level of service. Current construction schedule is unknown, however plans have been developed and construction may occur in 2020. However, until the project is fully constructed, this intersection will be significantly impact by the project based upon the Existing Plus Project scenario analysis. Therefore, no mitigation is proposed by the project applicant.

5.3 EXISTING WITH PROJECT CONDITIONS ROADWAY SEGMENT LOS

Table 12 presents the results of the Existing With Project conditions roadway segment level of service analysis. The roadway segment IDs (A through F) are shown graphically on **Exhibit 3**. As shown, all of the roadway segments are forecast to operate at acceptable levels of service (C or better) based on daily capacity thresholds with the addition of project-related traffic. Therefore, no significant impacts have been identified and no mitigation measures are required.

TABLE 12, EXISTING WITH PROJECT CONDITIONS ROADWAY SEGMENT LOS

Segment	Location	No. Lanes	Roadway Alignment	LOS E Capacity ¹	Existing			Existing With Project			Δ V/C	Sig. Impact?	
					ADT	V/C	LOS	ADT	V/C	LOS			
Lytle Creek Road	Duncan Canyon Rd. to Proposed Realignment Diverge Point (West)	A	2	Existing	12,000	180	0.02	A	430	0.04	A	0.021	No
		B	4	Proposed	-	-	-	-	-	-	-	-	-
	Proposed Realignment Diverge Point (West) to Proposed Project Dwy.	C	2	Existing	12,000	400	0.03	A	650	0.05	A	0.021	No
	Proposed Project Dwy. To Proposed Realignment Diverge Point (East)	D	2	Existing	12,000	400	0.03	A	1,080	0.09	A	0.057	No
	Proposed Realignment Diverge Point (East) to Sierra Avenue	E	2	Existing	12,000	610	0.05	A	-	-	-	0.239	No
		F	2	Proposed	12,000	-	-	-	3,480	0.29	A		

¹Source: City of Fontana General Plan Circulation Element Appendix C; Table A

ADT= Average Daily Traffic

LOS= Level of Service

V/C= Volume to Capacity Ratio

Δ= Difference

6 OPENING YEAR 2020 WITHOUT PROJECT CONDITIONS

Opening Year 2020 Without Project conditions assumes the following roadway improvements to the project study area which is expected to be completed by project opening Year 2020:

- Signalization of the Sierra Avenue / Riverside Avenue intersection with an additional northbound through lane consistent with the City of Fontana's Street Improvements for Traffic Signal plans;
- Realignment of the southwest portion of Lytle Creek Road as an extension of the existing Coyote Canyon Road west of the project site (to be constructed by other parties);
- As part of the Lytle Creek Road realignment west of the project site, signalization of Coyote Canyon Road / Duncan Canyon Road is assumed based on the existing lane geometry;
- Removal of approximately 0.83 miles of existing Lytle Creek Road; and
- Extension of Duncan Canyon Road from Citrus Avenue to Sierra Avenue.

6.1 OPENING YEAR 2020 WITHOUT PROJECT CONDITIONS TRAFFIC VOLUMES

To derive Opening Year 2020 Without Project conditions traffic volumes, an annual growth rate of 2% per year was applied to existing traffic volumes from existing conditions (2018) to project opening (2020) to account for general regional growth in the vicinity of the project site. The growth rate was based on the adopted Southern California Association of Governments (SCAG) 2016 Regional Transportation Plan growth forecasts for City of Fontana based on population, households and employment.

Additionally, approved or pending projects within the City of Fontana, City of Rialto, and San Bernardino County that are anticipated to be completed prior to project opening and forecast to contribute traffic to the study area were identified. Forecast traffic related to these future developments were added to the existing plus ambient growth traffic volumes. **Table 13** presents the list of cumulative projects identified with the direction of City staff and the forecast trip generation estimated for each project. A total of 27 cumulative projects were considered and 18 cumulative projects were found to contribute traffic to the project's study area. For large Specific Plan projects (greater than 10,000 ADT) the analysis conservatively assumes a phased construction of what could be reasonably constructed by the project's Opening Year of 2020 without oversaturating the housing and commercial markets within the region. The remaining development of these Specific Plan projects would be constructed after the project's opening year and is included in the Horizon Year 2040 analysis. In addition, the Opening Year analysis conservatively assumes a 2% per year growth above existing volumes to account for regional and local growth on the roadways.

The phasing assumptions used in this analysis for the larger Specific Plans for the Opening Year 2020 analysis are summarized in **Table 13**.

Exhibit 12 shows the location of the cumulative projects and **Exhibit 13** shows the AM and PM peak hour and daily traffic volumes of the cumulative projects identified in **Table 13**.

Exhibit 14 shows the Opening Year 2020 Without Project conditions AM and PM peak hour and daily traffic volumes at study intersections.

TABLE 13, CUMULATIVE PROJECTS TRIP

Project	Jurisdiction	Land Use	Size	ADT	AM Peak Hour			PM Peak Hour			
					Total	Inbound	Outbound	Total	Inbound	Outbound	
1	Monarch Hills	Fontana	Single Family Residential	233 DU	2,200	172	43	129	231	146	85
			Multi Family Residential	256 DU	1,874	118	27	91	143	90	53
			Subtotal		4,074	290	70	220	374	236	138
2	Lytle Creek Village ¹	Fontana	Apartments	650 DU	3,891	332	65	267	363	234	129
			Commercial/Retail	70 KSF	2,557	67	42	25	220	111	109
			Church	830 Seats	410	25	16	9	25	12	13
			Subtotal (Net External Trips)		6,858	424	123	301	608	357	251
3	Sierra Crest II - Tract 18944	Fontana	Single Family Residential	179 DU	1,690	132	33	99	177	112	65
4	Sierra Lakes Commerce Center - 6101 Sierra Ave.	Fontana	Warehouse	597.82 KSF	1,040	102	79	23	114	31	83
5	Summit Crest - Tract 18825-1	Fontana	Single Family Residential	76 DU	717	56	14	42	75	47	28
6	Stratham Development - Tract 18825	Fontana	Single Family Residential	76 DU	717	56	14	42	75	47	28
7	Stone Haven - Tract 18881 ³	Fontana	Single Family Residential	18 DU	170	13	3	10	18	11	7
8	Tract 18915	Fontana	Single Family Residential	96 DU	906	71	18	53	95	60	35
9	Steven Walker - Tract 18987 ³	Fontana	Single Family Residential	102 DU	963	75	19	56	101	64	37
10	Grand Pacific Communities - Tract 18981 ³	Fontana	Single Family Residential	105 DU	991	78	20	59	104	66	38
11	Citrus Heights North	Fontana	Private Park	1.5 Acres	Negligible						
			Single Family Residential	167 DU	1,576	124	31	93	165	104	61
			Multi Family Residential	412 DU	3,016	190	44	146	231	146	85
			Subtotal		4,592	314	75	239	396	250	146
12	Arboretum Specific Plan	Fontana	Single Family Residential	963 DU	9,091	713	178	535	953	600	353
			Multi Family Residential	2569 DU	18,805	1,182	272	910	1,439	907	532
			City Parks	31.1 Acres	24	1	1	0	3	2	1
			Recreation Center	26.83 KSF	773	47	31	16	62	29	33
			Elementary School	400 Students	756	268	145	123	68	33	35
			K-8 School	800 Students	3,288	728	400	328	208	96	112
			Subtotal (Assume 50% Constructed by Opening Year)⁴		16,369	1,470	514	956	1,367	834	533
13	Ventana Specific Plan	Fontana	Single Family Residential	504 DU	4,758	373	93	280	499	314	185
			Multi Family Residential	338 DU	2,474	155	36	119	189	119	70
			Retail	215.57 KSF	8,138	203	126	77	821	394	427
			Office	362.93 KSF	3,535	421	362	59	417	67	350
			Subtotal (Assume 75% Constructed by Opening Year)⁴		14,179	864	463	401	1,445	671	774
14	Summit at Rosena Specific Plan	Fontana	Single Family Residential	600 DU	5,664	444	111	333	594	374	220
15	West Gate Specific Plan ³	Fontana	Single Family Residential	826 DU	7,797	611	153	458	818	515	303
			Multi Family Residential	2422 DU	17,729	1,114	256	858	1,356	854	502
			Commercial/Retail	292.5 Acres	11,042	275	171	105	1,114	535	579
			Industrial Warehouse	1114.27 KSF	1,939	189	146	43	212	57	155
			High School	2711 Students	5,503	1,410	945	465	380	182	198
			Elementary School	715 Students	1,351	479	259	220	122	59	63
			Public Parks	33.1 Acres	26	1	1	0	4	2	2
Subtotal		45,387	4,079	1,931	2,149	4,006	2,204	1,802			

TABLE 13, CUMULATIVE PROJECTS TRIP GENERATION CONT.

Project	Jurisdiction	Land Use	Size	ADT	AM Peak Hour			PM Peak Hour			
					Total	Inbound	Outbound	Total	Inbound	Outbound	
16	Jiffy Lube - ASP16-000014 ³	Fontana	Tire Center	4.69 KSF	134	13	8	5	19	8	11
17	Journey Community Church - DRP10-002	Fontana	Church	35.5 KSF	247	12	7	5	17	8	9
18	Sierra Lakes Shopping Center ASP16-000050	Fontana	Retail	4.14 KSF	156	4	2	2	16	8	8
19	Sierra Lakes Shopping Center ASP14-000042 ³	Fontana	Animal Hospital	4.44 KSF	95	16	11	5	16	6	10
20	Sierra Lakes Shopping Center ASP14-000031 ³	Fontana	Retail	6.18 KSF	233	6	4	2	24	12	12
21	Sierra Lakes Shopping Center ASP14-000009	Fontana	Drive Thru Restaurant	6.11 KSF	2,878	246	125	121	200	104	96
			Medical Office	10.69 KSF	372	30	23	7	37	10	27
			Daycare Center	10.7 KSF	510	118	63	55	119	56	63
			Subtotal		3,760	394	211	183	356	170	186
22	210 Sports Park ³	Fontana	Baseball/Softball Fields	14 Fields	999	14	9	5	230	152	78
23	Promenade Specific Plan	Fontana	Single Family Residential	188 DU	1,775	139	35	104	186	117	69
			Park/Rec Center	1.9 Acres	55	3	2	1	4	2	2
			Walmart	193 KSF	9,785	357	200	157	836	410	426
			Restaurant	12 KSF	3,782	25	17	8	170	94	77
			Retail	11.6 KSF	438	11	7	4	44	21	23
			Conv. Store & Gas Sta. w/ Car Wash	12 VFP	2,464	150	77	74	168	86	82
			Fast Food Drive Thru	9.4 KSF	4,427	378	193	185	307	160	147
Subtotal (Assume 50% Constructed by Opening Year)⁴		11,363	532	266	267	858	445	413			
24	Highland Village	Fontana	Shopping Center	87 KSF	3,284	82	51	31	331	159	172
			Restaurant	6 KSF	1,891	12	8	4	85	47	38
			Medical Office	25 KSF	870	70	55	15	87	24	63
			Subtotal		6,045	164	114	50	503	230	273
25	Sycamore Creek	SBC	Apartments	298 DU	2,181	137	32	105	167	105	62
			Condominiums	90 DU	659	41	9	32	50	32	19
			Subtotal		2,840	178	41	137	217	137	81
26	Renaissance Specific Plan ²	Rialto	Residential (Various)	1262 DU	-	-	-	-	-	-	-
			Retail	715.3 KSF	-	-	-	-	-	-	-
			Commercial/Retail	386.7 KSF	-	-	-	-	-	-	-
			General Commercial	28.3 KSF	-	-	-	-	-	-	-
			Corporate Center	319.9 KSF	-	-	-	-	-	-	-
			Business Center	6,900 KSF	-	-	-	-	-	-	-
			Employment	7,100 KSF	-	-	-	-	-	-	-
Subtotal (Assume 30% Constructed by Opening Year)⁴		37,230	2,860	2,167	693	3,365	1,054	2,312			
27	Lytle Creek Ranch Specific Plan Phase	Rialto	Single Family Residential	500 DU	4,720	370	93	278	495	312	183
Total Cumulative Project Trips					172,139	13,030	6,419	6,614	15,664	7,905	7,761

¹ Source: Lytle Creek Road Alignment Study (Urban Crossroads May 2016)
² Source: Renaissance Specific Plan Amendment TIA (LSA, September 2016)
³ Cumulative Project Traffic not anticipated to contribute to study area
⁴ Assumed phasing of large projects (> 10,000 ADT)

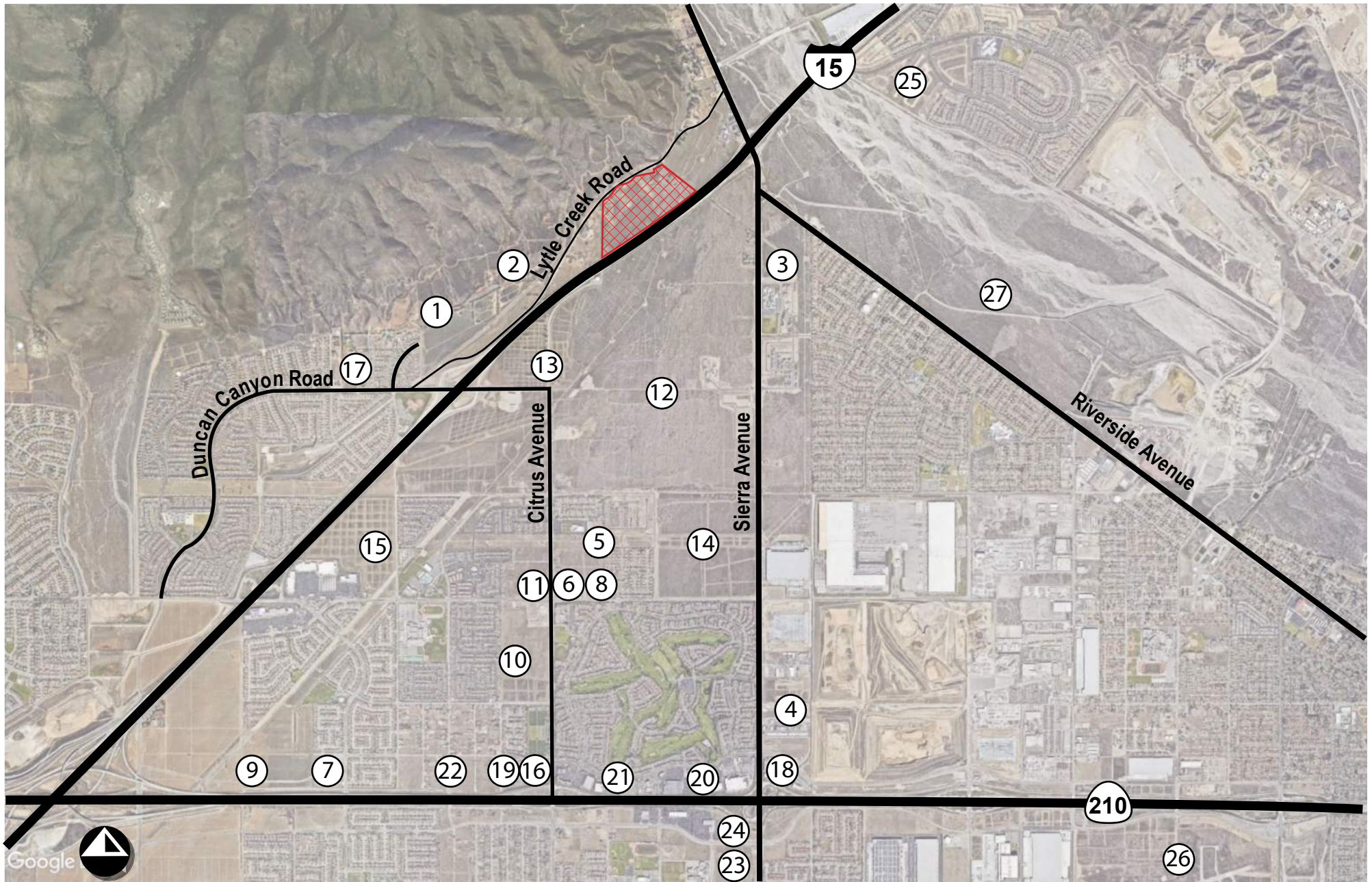

Not to Scale

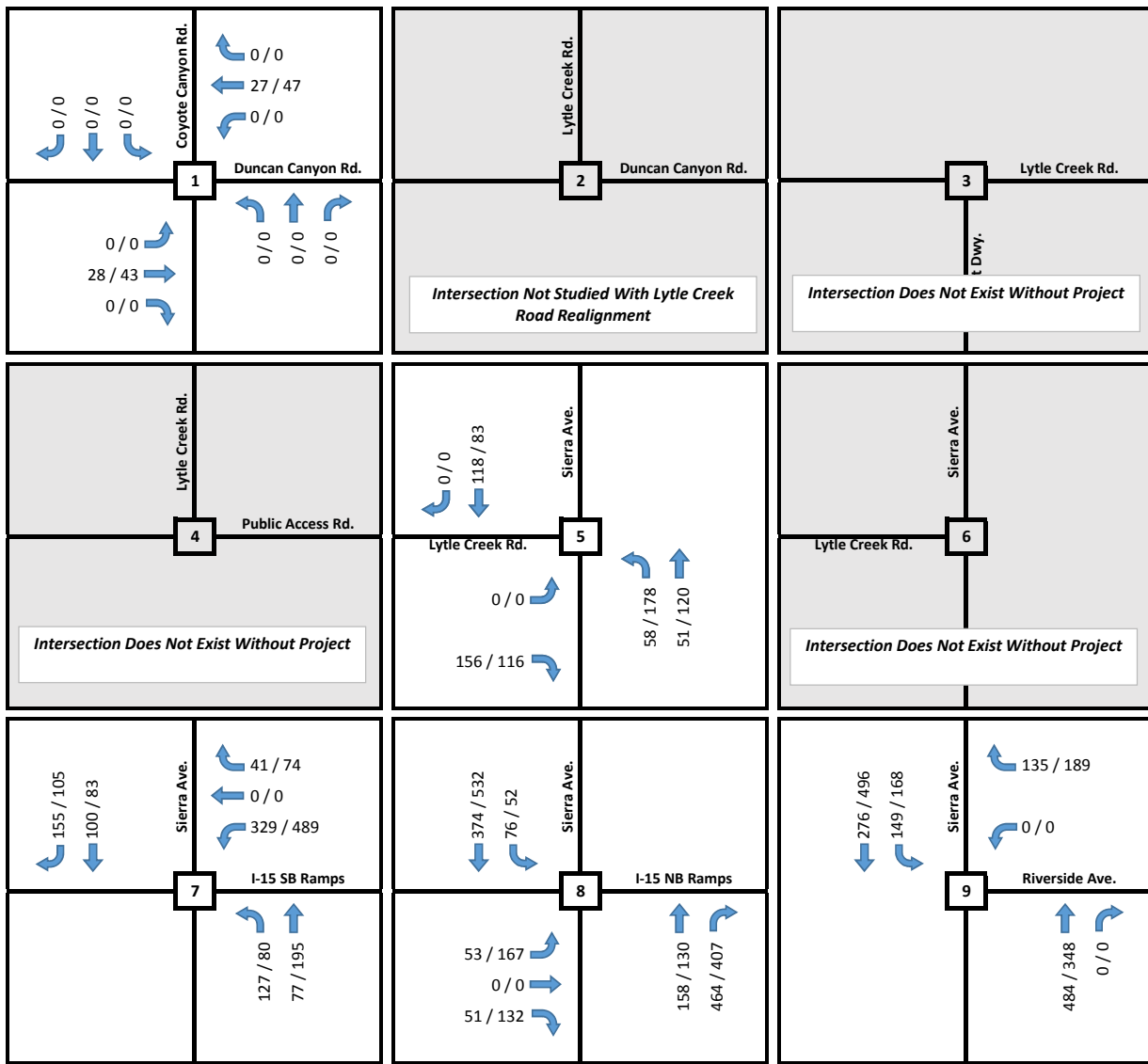

Notes: XX / XX = AM / PM Peak Hour Volumes in PCE's
 ### = Estimated Daily Traffic Volumes



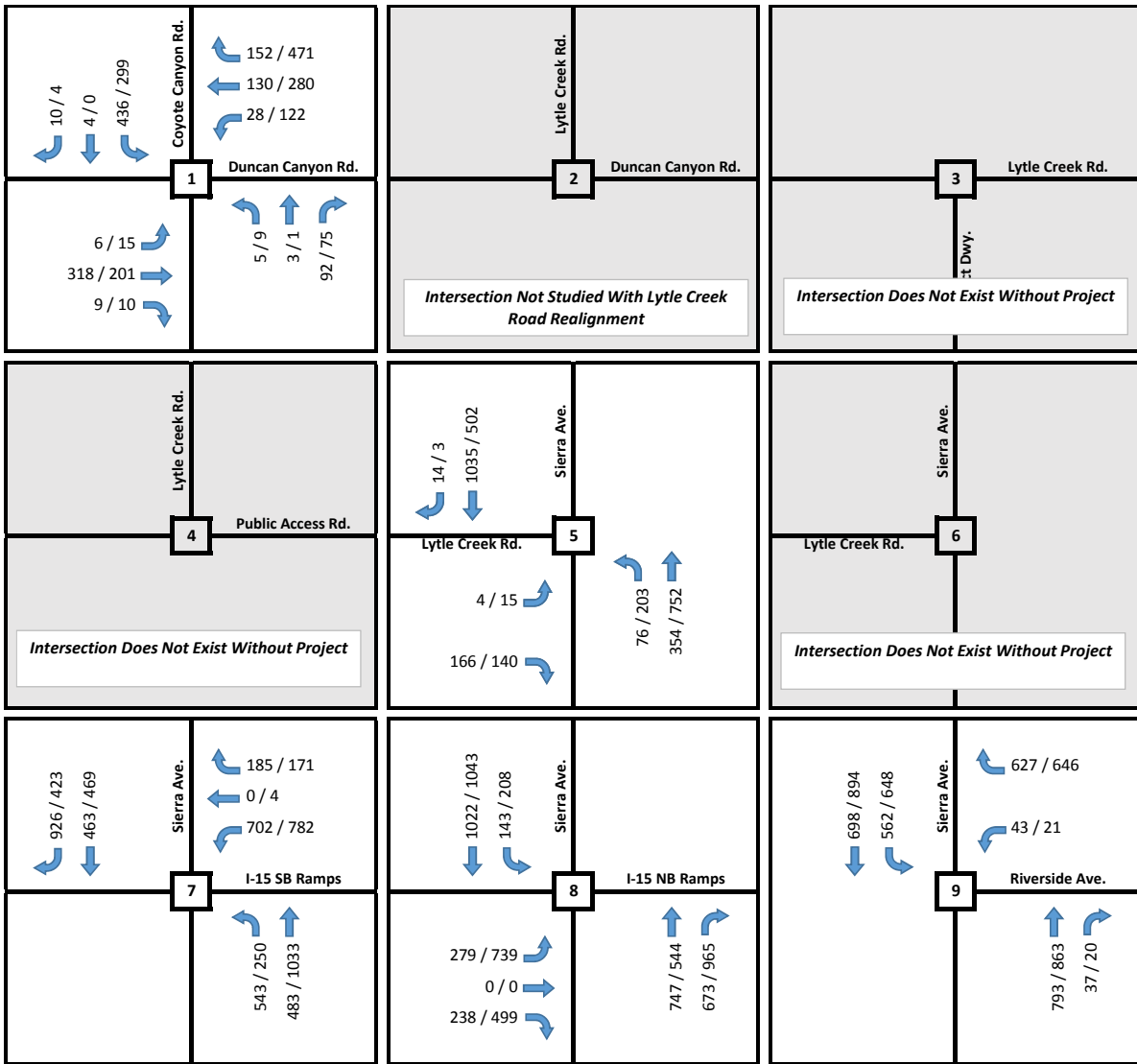

Notes: XX / XX = AM / PM Peak Hour Volumes in PCE's
 ### = Estimated Daily Traffic Volumes

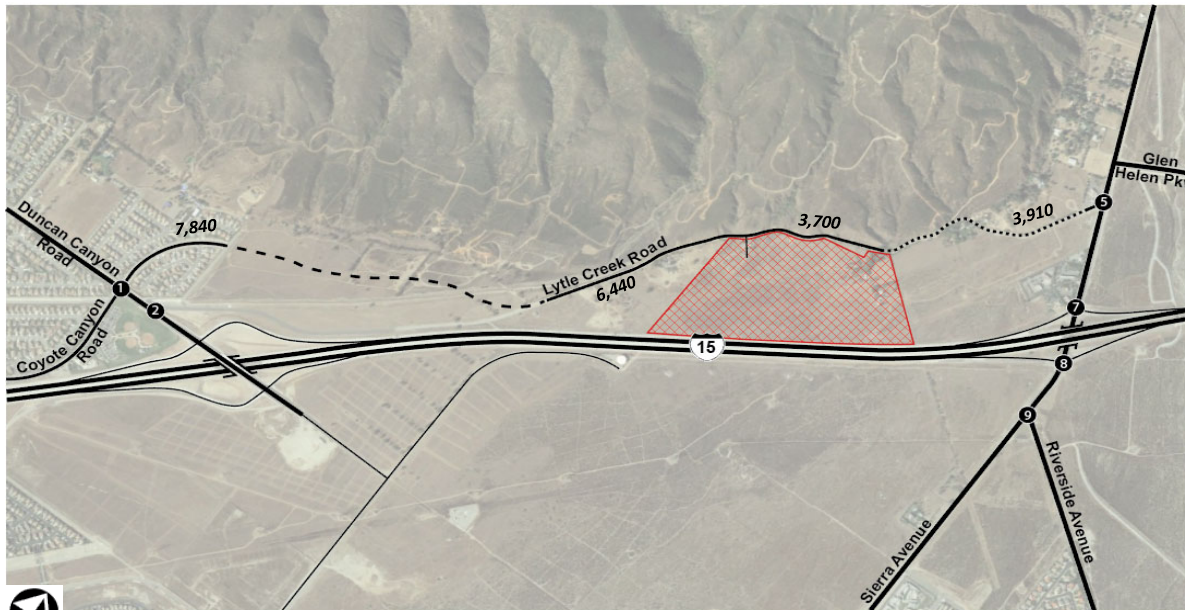

6.2 OPENING YEAR 2020 WITHOUT PROJECT CONDITIONS PEAK HOUR STUDY INTERSECTION LOS

Table 14 summarizes Opening Year 2020 Without Project conditions AM and PM peak hour level of service for all study intersections. Detailed analysis sheets are contained in **Appendix E**.

As shown in **Table 14**, all study intersections are forecast to operate at an acceptable level of service (LOS C or better) during the peak hours under Opening Year 2020 Without Project conditions with the following exceptions:

- Sierra Avenue / I-15 Southbound Ramps (LOS F in AM peak hour)
- Sierra Avenue / I-15 Northbound Ramps (LOS F in PM peak hour)
- Sierra Avenue / Riverside Avenue (LOS D in AM & PM peak hour)

As previously discussed, the intersection of Coyote Canyon Road / Duncan Canyon Road is assumed to be signalized with the realignment of Lytle Creek Road. For the Opening Year 2020 Without Project Condition, the existing un-signalized intersection of Coyote Canyon Road / Duncan Canyon Road was evaluated for signalization based on the peak hour signal warrant (Warrant #3) outlined in the California Manual on Uniform Traffic Control Devices (CA MUTCD), 2014 Edition. Based on the signal warrant evaluation, a signal is projected to be warranted in the AM and PM peak hour at Coyote Canyon Road / Duncan Canyon Road. Detailed CA MUTCD signal warrant analysis sheets are contained in **Appendix A**.

**TABLE 14, OPENING YEAR 2020 WITHOUT PROJECT CONDITIONS
AM/PM PEAK HOUR INTERSECTION LOS**

Study Intersection	Traffic Control	Opening Year 2020 Without Project Conditions	
		AM Delay ¹ - LOS	PM Delay ¹ - LOS
1 - Coyote Canyon Rd / Duncan Canyon Rd	Signal	18.1 - B	30.2 - C
2 - Lytle Creek Rd / Duncan Canyon Rd	OWSC	Not Studied With Lytle Creek Road Realignment	
3 - Project Dwy / Lytle Creek Rd	OWSC	Does Not Exist Without Project	
4 - Lytle Creek Rd / Public Access Rd	OWSC	Does Not Exist Without Project	
5 - Sierra Ave / Lytle Creek Rd (W/o Realignment)	OWSC	23.6 - C	16.2 - C
6 - Sierra Ave / Lytle Creek Rd (W/ Realignment)	OWSC	Does Not Exist Without Project	
7 - Sierra Ave / I-15 SB Ramps	Signal	> 80.0 - F	27.6 - C
8 - Sierra Ave / I-15 NB Ramps	Signal	19.3 - B	> 80.0 - F
9 - Sierra Ave / Riverside Ave	Signal	38.0 - D	40.9 - D

Note: Deficient intersection operation indicated in **bold**.

¹ Average seconds of delay per vehicle.

LOS = level of service.

DNE = Does Not Exist.

TWSC = Two-Way Stop Control

OWSC = One-Way Stop Control

6.3 OPENING YEAR 2020 WITHOUT PROJECT STREET SEGMENT LOS

Table 15 presents the results of the Opening Year 2020 Without Project conditions roadway segment level of service analysis. The roadway segment IDs (A through F) are shown graphically on **Exhibit 3**. As shown, all of the roadway segments are forecast to operate at acceptable levels of service (C or better) based on daily capacity thresholds.

TABLE 15, OPENING YEAR 2020 WITHOUT PROJECT CONDITIONS ROADWAY SEGMENT LOS

Segment	Location	Roadway Alignment	No. Lanes	LOS E Capacity ¹	Opening Year 2020 Without Project		
					ADT	V/C	LOS
Lytle Creek Road	Duncan Canyon Rd. to Proposed Realignment Diverge Point (West)	A Existing	2	-	-	-	-
		B Proposed	4	24,000	7,840	0.33	A
	Proposed Realignment Diverge Point (West) to Proposed Project Dwy.	C Existing	2	12,000	6,440	0.54	A
	Proposed Project Dwy. To Proposed Realignment Diverge Point (East)	D Existing	2	12,000	3,700	0.31	A
	Proposed Realignment Diverge Point (East) to Sierra Avenue	E Existing	2	12,000	3,910	0.33	A
		F Proposed	2	-	-	-	-

¹Source: City of Fontana General Plan Circulation Element Appendix C; Table A

ADT= Average Daily Traffic

LOS= Level of Service

V/C= Volume to Capacity Ratio

7 OPENING YEAR 2020 WITH PROJECT CONDITIONS

7.1 OPENING YEAR 2020 WITH PROJECT CONDITIONS TRAFFIC VOLUMES

Opening Year 2020 With Project conditions traffic volumes are derived by adding trips forecast to be generated by the proposed project to Opening Year 2020 Without Project conditions traffic volumes.

Exhibit 15 shows the forecast Opening Year 2020 With Project conditions AM and PM peak hour and daily traffic volumes at study intersections.

7.2 OPENING YEAR 2020 WITH PROJECT CONDITIONS PEAK HOUR STUDY INTERSECTION LOS

Table 16 summarizes Opening Year 2020 With Project conditions AM and PM peak hour level of service for all study intersections. It should be noted the project is responsible for constructing a new traffic signal at Sierra Avenue / Lytle Creek Road (Int. #6) with the proposed realignment. A traffic signal was determined to be warranted in the Lytle Creek Road Alignment Study (May 31, 2016) and therefore, a signal is assumed to be installed as part of the road realignment. Detailed analysis sheets are contained in **Appendix F**.

**TABLE 16, OPENING YEAR 2020 WITH PROJECT CONDITIONS
AM/PM PEAK HOUR INTERSECTION LOS**

Study Intersection	Traffic Control	Opening Year 2020 Without Project Conditions		Opening Year 2020 With Project Conditions		Change in Delay (sec.)		Significant Impact?	
		AM	PM	AM	PM	AM	PM	AM	PM
		Delay ¹ - LOS	Delay ¹ - LOS	Delay ¹ - LOS	Delay ¹ - LOS				
1 - Coyote Canyon Rd / Duncan Canyon Rd	Signal	18.1 - B	30.2 - C	19.3 - B	31.7 - C	1.2	1.5	No	No
2 - Lytle Creek Rd / Duncan Canyon Rd	OWSC	Not Studied With Lytle Creek Road Realignment				—	—	No	No
3 - Project Dwy / Lytle Creek Rd	OWSC	Does Not Exist Without Project		9.8 - A	10.1 - B	—	—	No	No
4 - Lytle Creek Rd / Public Access Rd	OWSC	Does Not Exist Without Project		12.1 - B	13.4 - B	—	—	No	No
5 - Sierra Ave / Lytle Creek Rd (W/o Realignment)	OWSC	23.6 - C	16.2 - C	Not Studied With Project		—	—	No	No
6 - Sierra Ave / Lytle Creek Rd (W/ Realignment) ²	Signal	Does Not Exist Without Project		31.3 - C	23.7 - C	—	—	No	No
7 - Sierra Ave / I-15 SB Ramps	Signal	> 80.0 - F	27.6 - C	> 80.0 - F	28.4 - C	0.9	0.8	No	No
8 - Sierra Ave / I-15 NB Ramps	Signal	19.3 - B	> 80.0 - F	21.9 - C	> 80.0 - F	2.6	16.7	No	YES
9 - Sierra Ave / Riverside Ave	Signal	38.0 - D	40.9 - D	40.9 - D	42.9 - D	2.9	2.0	No	No

Note: Deficient intersection operation indicated in **bold**.

LOS = Level of Service

¹ Seconds of delay per vehicle.

OWSC = One-Way Stop Control

² A traffic signal was determined to be warranted per the Lytle Creek Road Alignment Study (May 31, 2016), thus a traffic signal is assumed with the road realignment.

As shown in **Table 16**, all study intersections are forecast to operate at an acceptable level of service (LOS C or better) during the peak hours under Opening Year 2020 With Project conditions with the following exceptions:

- Sierra Avenue / I-15 Southbound Ramps (LOS F in AM peak hour)
- Sierra Avenue / I-15 Northbound Ramps (LOS F in PM peak hour)
- Sierra Avenue / Riverside Avenue (LOS D in AM & PM peak hour)

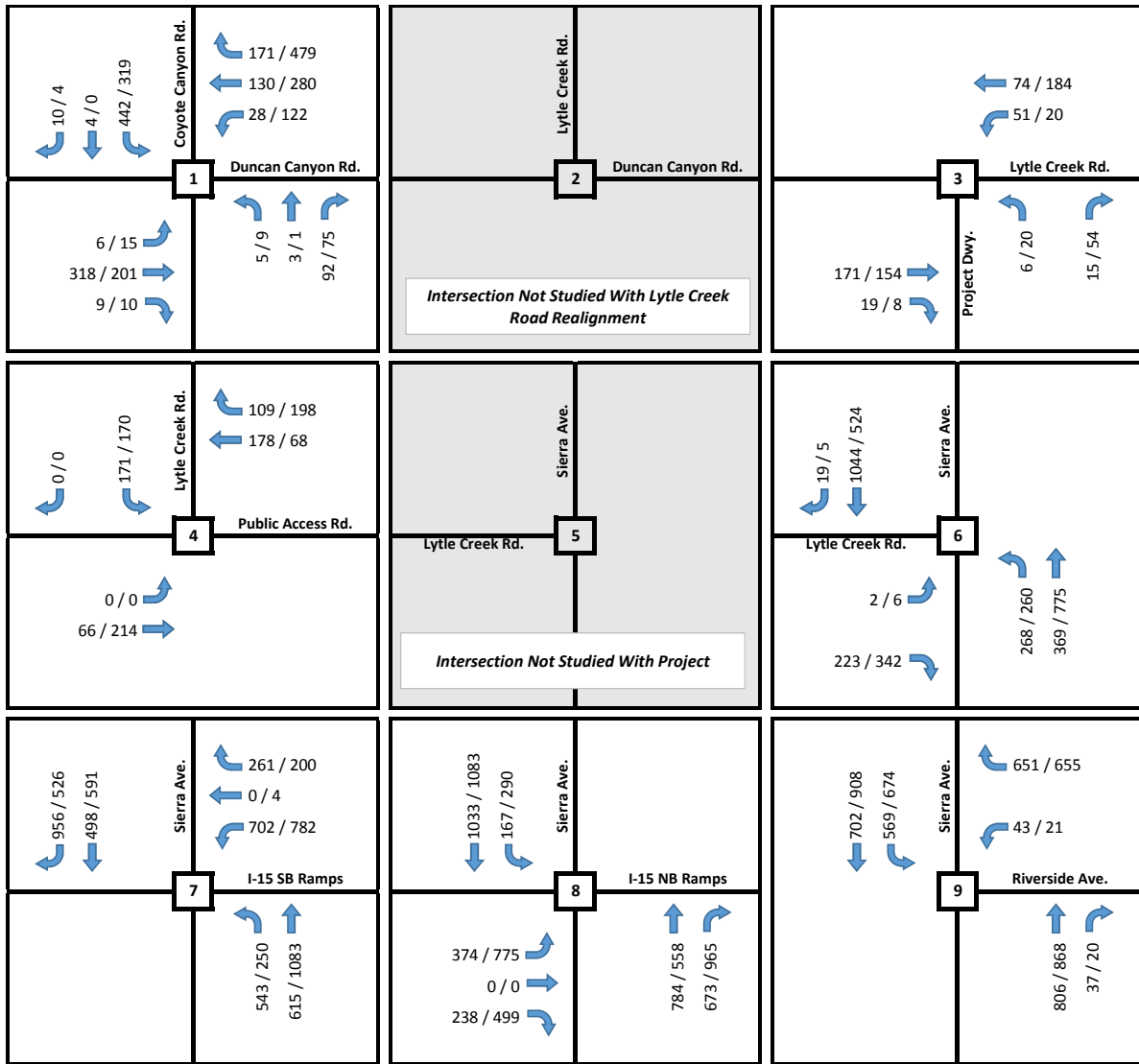

Notes: XX / XX = AM / PM Peak Hour Volumes in PCE's
 ### = Estimated Daily Traffic Volumes

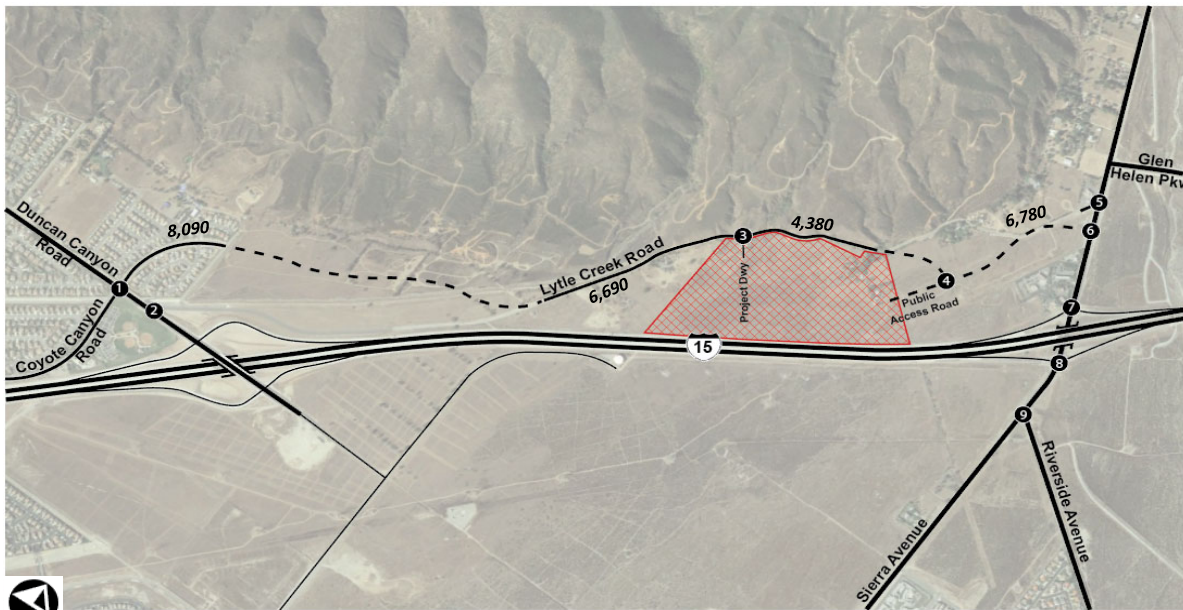

According to the *City of Fontana Traffic Impact Analysis Guidelines* significance criteria, the following intersection is significantly impacted as a result of the proposed project and therefore, mitigation is required:

- Sierra Avenue / I-15 Northbound Ramps (PM peak hour)

The following mitigation measures are recommended to mitigate the intersection impacts.

Mitigation Measure #2: Sierra Avenue / I-15 Northbound Ramps

There are no specific improvements identified at the I-15/Sierra Ave. interchange by the Caltrans or San Bernardino County, therefore, no mitigation is proposed. The project-related traffic impact at this location is considered significant and unavoidable.

Exhibit 16 shows the Opening Year 2020 With Project mitigated lane configurations.

7.3 OPENING YEAR 2020 WITH PROJECT CONDITIONS ROADWAY SEGMENT LOS

Table 17 presents the results of the Opening Year 2020 With Project conditions roadway segment level of service analysis. The roadway segment IDs (A through F) are shown graphically on **Exhibit 3**. As shown, all of the roadway segments are forecast to operate at acceptable levels of service (C or better) based on daily capacity thresholds with the addition of project-related traffic. Therefore, no significant impacts have been identified and no mitigation measures are required.

TABLE 17, OPENING YEAR 2020 WITH PROJECT CONDITIONS ROADWAY SEGMENT LOS

Segment	Location	No. Lanes	Roadway Alignment	LOS E Capacity ¹	Opening Year 2020 Without Project			Opening Year 2020 With Project			Δ V/C	Sig. Impact?	
					ADT	V/C	LOS	ADT	V/C	LOS			
Lytle Creek Road	Duncan Canyon Rd. to Proposed Realignment Diverge Point (West)	A	2	Existing	-	-	-	-	-	-	-	-	
	Realignment Diverge Point (West)	B	4	Proposed	24,000	7,840	0.33	A	8,090	0.34	A	0.010	No
	Proposed Realignment Diverge Point (West) to Proposed Project Dwy.	C	2	Existing	12,000	6,440	0.54	A	6,690	0.56	A	0.021	No
	Proposed Project Dwy. To Proposed Realignment Diverge Point (East)	D	2	Existing	12,000	3,700	0.31	A	4,380	0.37	A	0.057	No
	Proposed Realignment Diverge Point (East) to Sierra Avenue	E	2	Existing	12,000	3,910	0.33	A	-	-	-	0.239	No
	Realignment Diverge Point (East) to Sierra Avenue	F	2	Proposed	12,000	-	-	-	6,777	0.56	A		

¹Source: City of Fontana General Plan Circulation Element Appendix C; Table A

ADT= Average Daily Traffic

LOS= Level of Service

V/C= Volume to Capacity Ratio

Δ= Difference

8 HORIZON YEAR 2040 WITHOUT PROJECT CONDITIONS

This section analyzes the potential traffic impacts for Horizon Year 2040 Without Project conditions at the study intersections and roadway segments.

Horizon Year Without & With Project conditions assumes the following roadway improvements at Sierra Avenue / Riverside Avenue:

- One additional northbound and southbound through lane on Sierra Avenue classified as a Major Highway and consistent with the City's General Plan Community Mobility and Circulation (Exhibit 9.2 in General Plan);
- One additional westbound right-turn lane to accommodate future development (by others); and
- One additional southbound left-turn lane to accommodate future development (by others).

8.1 HORIZON YEAR 2040 WITHOUT PROJECT CONDITIONS TRAFFIC VOLUMES

Horizon Year 2040 Without Project traffic volumes were based on a combination of cumulative projects and a background growth rate. As previously discussed, some of the Specific Plans listed in the cumulative project list were phased during the Opening Year 2020 scenario, therefore, the remaining development was added to the Horizon Year traffic volumes. In addition, a 1.95% per year growth was applied to the Opening Year 2020 Without Project traffic volumes to conservatively estimate volume forecasts for Year 2040. The growth rate was based on the adopted Southern California Association of Governments (SCAG) 2016 Regional Transportation Plan growth forecasts for City of Fontana based on population, households and employment.

Exhibit 16 shows the Horizon Year 2040 Without & With Project lane configurations for the study intersections.

Exhibit 17 shows the Horizon Year 2040 Without Project conditions AM and PM peak hour and daily traffic volumes at study intersections.

8.2 HORIZON YEAR 2040 WITHOUT PROJECT CONDITIONS PEAK HOUR STUDY INTERSECTION LOS

Table 18 summarizes Horizon Year 2040 Without Project conditions AM and PM peak hour level of service for all study intersections. Detailed analysis sheets are contained in **Appendix G**.

As shown, all study intersections are forecast to operate at an acceptable level of service (LOS C or better) during the peak hours under Horizon Year 2040 With Project conditions with the following exceptions:

- Sierra Avenue / Lytle Creek Road (without realignment) (LOS F in AM & PM peak hour)
- Sierra Avenue / I-15 SB Ramps (LOS F in AM peak hour)
- Sierra Avenue / I-15 NB Ramps (LOS E in the AM peak hour and LOS F in the PM peak hour)
- Sierra Avenue / Riverside Avenue (LOS D in PM peak hour)

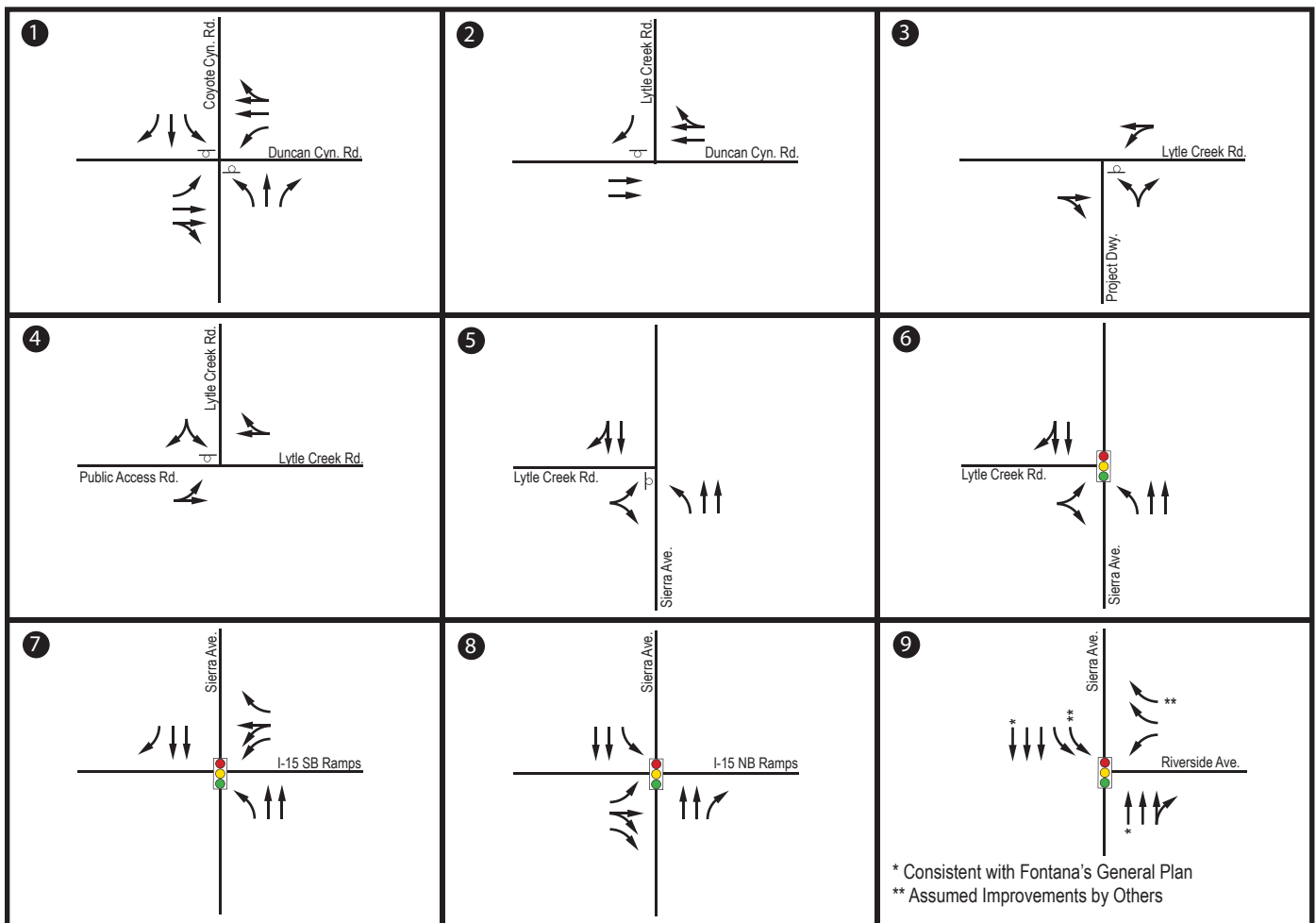

* Consistent with Fontana's General Plan
 ** Assumed Improvements by Others

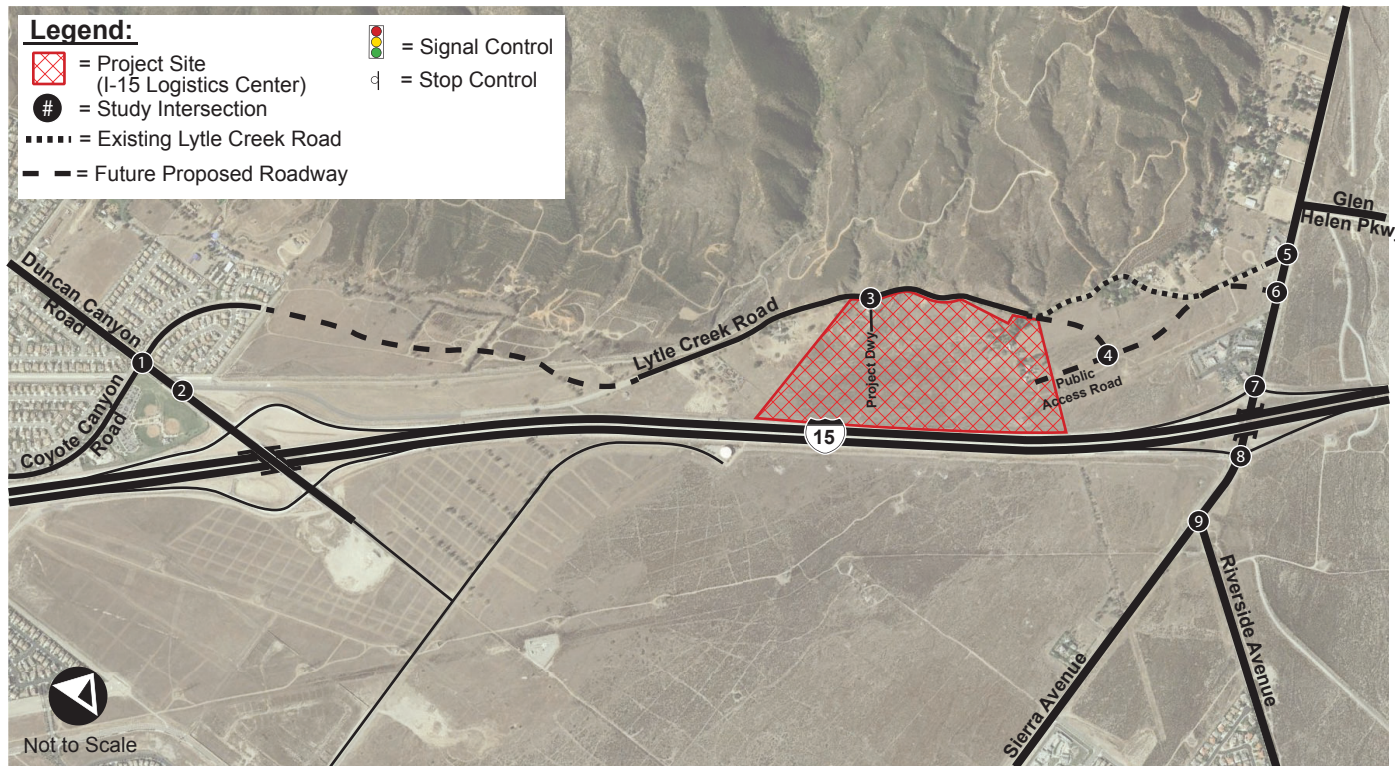

Horizon Year 2040 Without & With Project Lane Configurations

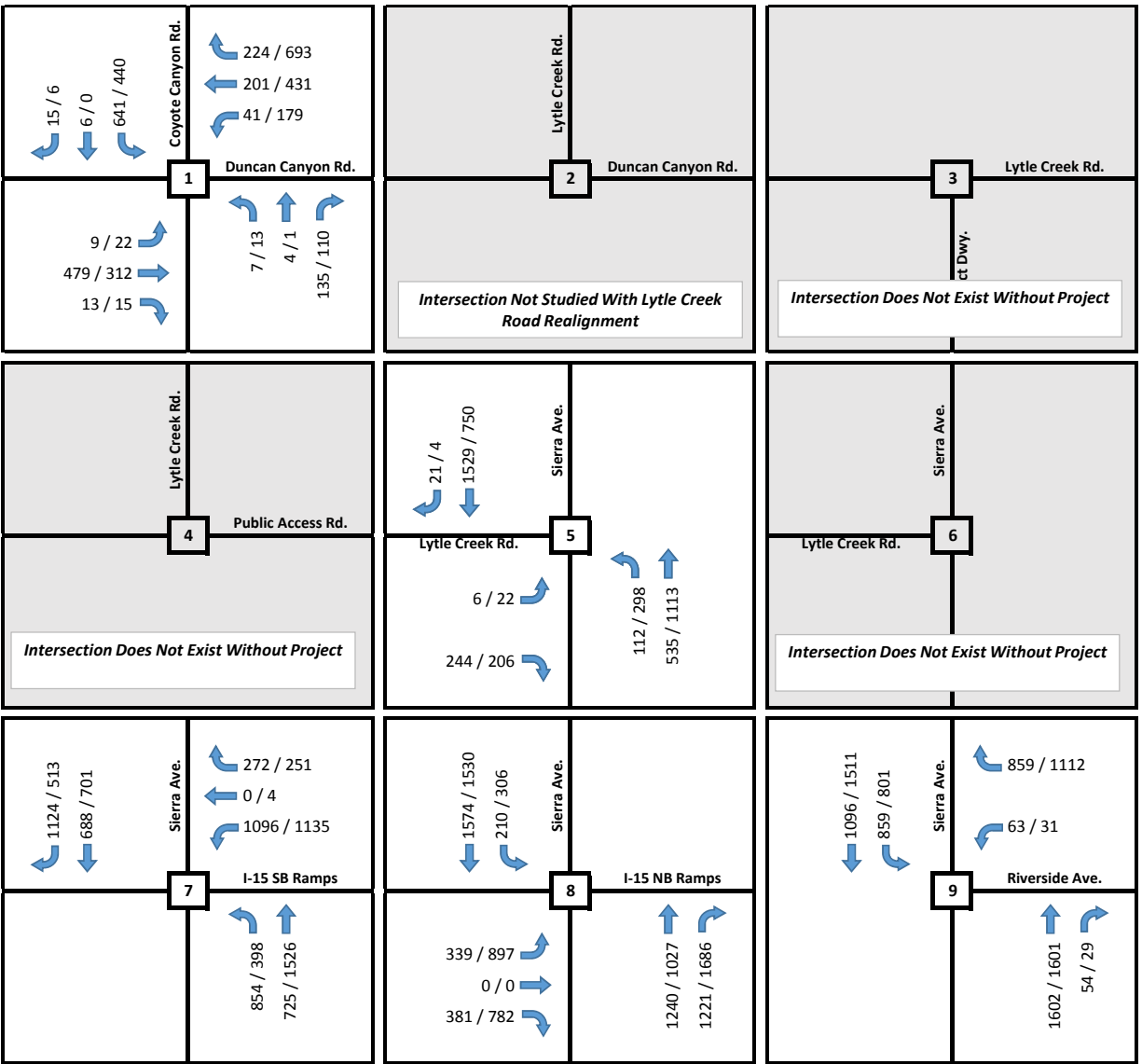

Notes: XX / XX = AM / PM Peak Hour Volumes in PCE's
= Estimated Daily Traffic Volumes



**TABLE 18, HORIZON YEAR 2040 WITHOUT PROJECT CONDITIONS
AM/PM PEAK HOUR INTERSECTION LOS**

Study Intersection	Traffic Control	Horizon Year 2040 Without Project Conditions	
		AM Delay ¹ - LOS	PM Delay ¹ - LOS
1 - Coyote Canyon Rd / Duncan Canyon Rd	Signal	33.1 - C	50.9 - D
2 - Lytle Creek Rd / Duncan Canyon Rd	OWSC	Not Studied With Lytle Creek Road Realignment	
3 - Project Dwy / Lytle Creek Rd	OWSC	Does Not Exist Without Project	
4 - Lytle Creek Rd / Public Access Rd	OWSC	Does Not Exist Without Project	
5 - Sierra Ave / Lytle Creek Rd (W/o Realignment)	OWSC	> 80.0 - F	> 80.0 - F
6 - Sierra Ave / Lytle Creek Rd (W/ Realignment)	OWSC	Does Not Exist Without Project	
7 - Sierra Ave / I-15 SB Ramps	Signal	> 80.0 - F	46.3 - D
8 - Sierra Ave / I-15 NB Ramps	Signal	74.2 - E	> 80.0 - F
9 - Sierra Ave / Riverside Ave	Signal	29.2 - C	41.6 - D

Note: Deficient intersection operation indicated in **bold**.

¹ Average seconds of delay per vehicle.

LOS = level of service.

OWSC = One-Way Stop Control

8.3 HORIZON YEAR 2040 WITHOUT PROJECT ROADWAY SEGMENT LOS

Table 19 presents the results of the Horizon Year 2040 Without Project conditions roadway segment level of service analysis. The roadway segment IDs (A through F) are shown graphically on **Exhibit 3**. As shown, all of the roadway segments are forecast to operate at acceptable levels of service (C or better) based on daily capacity thresholds.

TABLE 19, HORIZON YEAR 2040 WITHOUT PROJECT ROADWAY SEGMENT LOS

Segment	Location	Roadway Alignment	No. Lanes	LOS E Capacity ¹	Horizon Year 2040 Without Project		
					ADT ¹	V/C	LOS
Lytle Creek Road	Duncan Canyon Rd. to Proposed Realignment Diverge Point (West)	A Existing	-	-	-	-	-
		B Proposed	4	24,000	8,430	0.35	A
	Proposed Realignment Diverge Point (West) to Proposed Project Dwy.	C Existing	2	12,000	6,740	0.56	A
	Proposed Project Dwy. To Proposed Realignment Diverge Point (East)	D Existing	2	12,000	6,740	0.56	A
	Proposed Realignment Diverge Point (East) to Sierra Avenue	E Existing	2	12,000	5,050	0.42	A
		F Proposed	2	-	-	-	-

¹Source: City of Fontana General Plan Circulation Element Appendix C; Table A

ADT= Average Daily Traffic

LOS= Level of Service

V/C= Volume to Capacity Ratio

9 HORIZON YEAR 2040 WITH PROJECT CONDITIONS

9.1 HORIZON YEAR 2040 WITH PROJECT CONDITIONS TRAFFIC VOLUMES

Horizon Year 2040 With Project conditions traffic volumes are derived by adding trips forecast to be generated by the proposed project to Horizon Year 2040 Without Project conditions traffic volumes.

Exhibit 18 shows the forecast Horizon Year 2040 With Project conditions AM and PM peak hour and daily traffic volumes at study intersections.

9.2 HORIZON YEAR 2040 WITH PROJECT CONDITIONS PEAK HOUR STUDY INTERSECTION LOS

Table 20 summarizes Horizon Year 2040 With Project conditions AM and PM peak hour level of service for all study intersections. A traffic signal was determined to be warranted in the Lytle Creek Road Alignment Study (May 31, 2016) and therefore, a signal is assumed to be installed as part of the road realignment. Detailed analysis sheets are contained in **Appendix H**.

**TABLE 20, HORIZON YEAR 2040 WITH PROJECT CONDITIONS
AM/PM PEAK HOUR INTERSECTION LOS**

Study Intersection	Traffic Control	Horizon Year 2040 Without Project Conditions		Horizon Year 2040 With Project Conditions		Change in Delay (sec.)		Significant Impact?	
		AM	PM	AM	PM	AM	PM	AM	PM
		Delay ¹ - LOS	Delay ¹ - LOS	Delay ¹ - LOS	Delay ¹ - LOS				
1 - Coyote Canyon Rd / Duncan Canyon Rd	Signal	33.1 - C	50.9 - D	33.9 - C	53.6 - D	0.8	2.7	No	No
2 - Lytle Creek Rd / Duncan Canyon Rd	OWSC	Not Studied With Lytle Creek Road Realignment				—	—	No	No
3 - Project Dwy / Lytle Creek Rd	OWSC	Does Not Exist Without Project		10.9 - B	11.5 - B	—	—	No	No
4 - Lytle Creek Rd / Public Access Rd	OWSC	Does Not Exist Without Project		17.0 - C	21.7 - C	—	—	No	No
5 - Sierra Ave / Lytle Creek Rd (W/o Realignment)	OWSC	> 80.0 - F		Not Studied With Project		—	—	No	No
6 - Sierra Ave / Lytle Creek Rd (W/ Realignment) ²	Signal	Does Not Exist Without Project		34.4 - C	27.3 - C	—	—	No	No
7 - Sierra Ave / I-15 SB Ramps	Signal	> 80.0 - F	46.3 - D	> 80.0 - F	54.6 - D	18.0	8.3	YES	No
8 - Sierra Ave / I-15 NB Ramps	Signal	74.2 - E	> 80.0 - F	> 80.0 - F	> 80.0 - F	6.0	79.2	YES	YES
9 - Sierra Ave / Riverside Ave	Signal	29.2 - C	41.6 - D	29.7 - C	42.4 - D	0.5	0.8	No	No

Note: Deficient intersection operation indicated in **bold**.

LOS = Level of Service

¹ Seconds of delay per vehicle.

OWSC = One-Way Stop Control

² A traffic signal was determined to be warranted per the Lytle Creek Road Alignment Study (May 31, 2016), thus a traffic signal is assumed with the road realignment.

As shown in **Table 20**, all study intersections are forecast to operate at an acceptable level of service (LOS C or better) during the peak hours under Horizon Year 2040 With Project conditions with the following exceptions:

- Coyote Canyon Rd / Duncan Canyon Rd (LOS D in the PM peak hour)
- Sierra Avenue / I-15 SB Ramps (LOS F in the AM peak hour)
- Sierra Avenue / I-15 NB Ramps (LOS F in the AM & PM peak hour)
- Sierra Avenue / Riverside Avenue (LOS D in the PM peak hour)

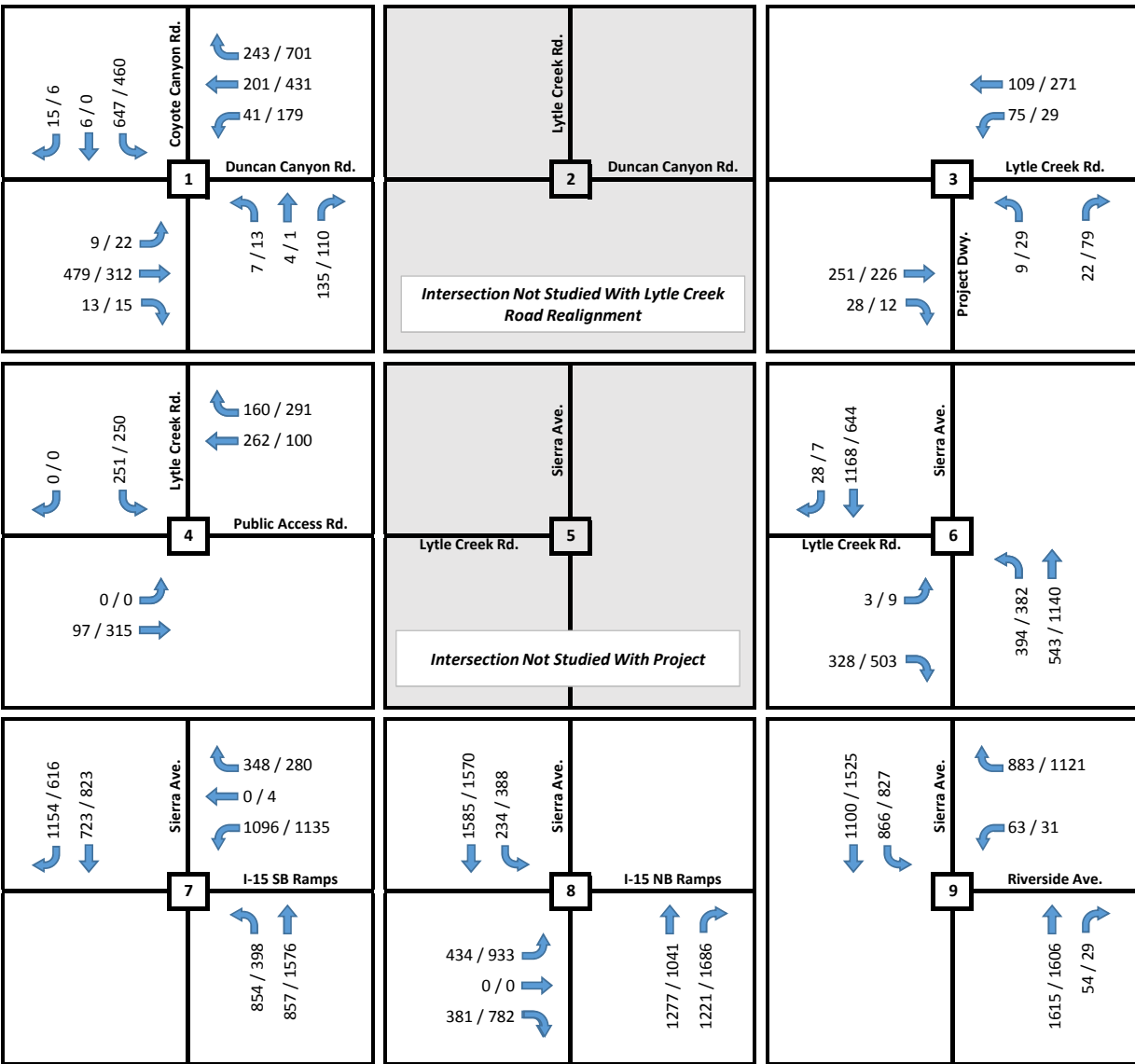

Notes: XX / XX = AM / PM Peak Hour Volumes in PCE's
 ### = Estimated Daily Traffic Volumes



According to the *City of Fontana Traffic Impact Analysis Guidelines* significance criteria, the following intersections are significantly impacted by the proposed project and therefore, mitigation is required:

- Sierra Avenue / I-15 SB Ramps (AM peak hour)
- Sierra Avenue / I-15 NB Ramps (AM & PM peak hour)

There are no specific improvements identified at the I-15/Sierra Ave. interchange by the Caltrans or San Bernardino County, therefore, no mitigation is proposed. The project-related traffic impact at this location is considered significant and unavoidable.

9.3 HORIZON YEAR 2040 WITH PROJECT ROADWAY SEGMENT LOS

Table 21 presents the results of the Horizon Year 2040 With Project conditions roadway segment level of service analysis. The roadway segment IDs (A through F) are shown graphically on **Exhibit 3**. As shown, all of the roadway segments are forecast to operate at acceptable levels of service (C or better) based on daily capacity thresholds.

TABLE 21, HORIZON YEAR 2040 WITH PROJECT ROADWAY SEGMENT LOS

Segment	Location	No. Lanes	Roadway Alignment	LOS E Capacity ¹	Horizon Year 2040 Without Project			Horizon Year 2040 With Project			Δ V/C	Sig. Impact?	
					ADT	V/C	LOS	ADT	V/C	LOS			
Lytle Creek Road	Duncan Canyon Rd. to Proposed Realignment Diverge Point (West)	A	2	Existing	-	-	-	-	-	-	-	-	
	Realignment Diverge Point (West)	B	4	Proposed	24,000	8,430	0.35	A	8,680	0.36	A	0.010	No
	Proposed Realignment Diverge Point (West) to Proposed Project Dwy.	C	2	Existing	12,000	6,740	0.56	A	6,990	0.58	A	0.021	No
	Proposed Project Dwy. To Proposed Realignment Diverge Point (East)	D	2	Existing	12,000	6,740	0.56	A	7,420	0.62	B	0.057	No
	Proposed Realignment Diverge Point (East) to Sierra Avenue	E	2	Existing	12,000	5,050	0.42	A	-	-	-	0.239	No
	Realignment Diverge Point (East)	F	2	Proposed	12,000	-	-	-	7,920	0.66	B		

¹Source: City of Fontana General Plan Circulation Element Appendix C; Table A

ADT= Average Daily Traffic

LOS= Level of Service

V/C= Volume to Capacity Ratio

Δ= Difference

10 FREEWAY MAINLINE ANALYSIS

This section of the report evaluates freeway mainline segments on Interstate 15 near the project site. Consistent with the City of Fontana Traffic Impact Study Guidelines, freeway segments with more than 100 two-way peak hour project trips were included in this analysis. The proposed project contributes approximately 101 trips (two-way) in the PM peak hour to Interstate 15 south of Duncan Canyon Road and 73 trips (two-way) in the PM peak hour north of Duncan Canyon Road. To be conservative, the following three freeway segments were analyzed:

- I-15 segment between Glen Helen Parkway and Sierra Avenue
- I-15 segment between Sierra Avenue and Duncan Canyon Road
- I-15 segment between Duncan Canyon Road and Beech Avenue

The study freeway mainline segments for Existing, Existing With Project, Opening Year 2020, Opening Year 2020 With Project, Horizon Year 2040, and Horizon Year 2040 With Project conditions were evaluated and the results of this analysis are presented in **Tables 22 - 27**. Under Existing and Existing With Project conditions, all three study freeway segments are operating at LOS D. In Opening Year 2020 Without and With Project conditions, freeway segments analyzed are forecast to operate at LOS E. For the Horizon Year 2040 Without and With Project conditions, the results of the analysis show freeway segments forecast to operate at LOS F.

At Caltrans facilities, LOS D is considered acceptable and LOS E or F is considered deficient. A significant impact occurs when project-related traffic causes a freeway mainline segment to deteriorate from an acceptable LOS (D or better) to a deficient LOS (E or F) or if the project contributes to an existing deficiency.

Freeway mainline segment analysis worksheets are provided in **Appendix I**.

TABLE 22, EXISTING FREEWAY MAINLINE SEGMENT LOS

I-15 Freeway Segment	No. Lanes	Direction	LOS "E" Capacity	ADT ⁽¹⁾	Peak Hour % ⁽¹⁾	Directional Split ⁽¹⁾	Truck Factor ⁽¹⁾	PHV ⁽²⁾	V/C	LOS
	General									
Glen Helen Pkwy. to Sierra Ave.	4	NB	8,800	127,000	12.66%	51.93%	88.55%	7,393	0.840	D
	4	SB	8,800	127,000	12.00%	55.00%	88.55%	7,422	0.843	D
Sierra Ave. to Duncan Canyon Rd.	4	NB	8,800	127,000	12.66%	51.93%	88.55%	7,393	0.840	D
	4	SB	8,800	127,000	12.00%	55.00%	88.55%	7,422	0.843	D
Duncan Cayon Rd. to Beech Ave.	4	NB	8,800	127,000	12.66%	51.93%	88.55%	7,393	0.840	D
	4	SB	8,800	127,000	12.00%	55.00%	88.55%	7,422	0.843	D

Deficient LOS indicated in **bold**.

ADT = Average Daily Traffic

PHV = Peak Hour Volume (Highest Hour)

V/C = Volume to Capacity Ratio

LOS = Level of Service

Maximum level of service "E" capacity for General Purpose Mainlanes is assumed to be 2,200 vehicles per hour per lane (vphpl) based upon the 2016 SANBAG Guideline

⁽¹⁾ Data taken from Caltrans Count Data (2016)

⁽²⁾ Peak hour volume (PHV) calculation = ADT x Peak Hour Percent x Directional Split x Truck Factor which is taken from Caltrans website.

TABLE 23, EXISTING WITH PROJECT FREEWAY MAINLINE SEGMENT LOS

I-15 Freeway Segment	No. Lanes	Direction	Capacity	Existing Conditions				Existing With Project Conditions				Sig. Impact?	
	General			ADT	PHV ⁽¹⁾	V/C	LOS	ADT	PHV ⁽¹⁾	V/C	LOS	AM	PM
Glen Helen Pkwy. to Sierra Ave.	4	NB	8,800	127,000	7,393	0.840	D	127,900	7,445	0.846	D	No	No
	4	SB	8,800	127,000	7,422	0.843	D	127,800	7,471	0.849	D	No	No
Sierra Ave. to Duncan Canyon Rd.	4	NB	8,800	127,000	7,393	0.840	D	127,900	7,444	0.846	D	No	No
	4	SB	8,800	127,000	7,422	0.843	D	127,900	7,477	0.850	D	No	No
Duncan Cayon Rd. to Beech Ave.	4	NB	8,800	127,000	7,393	0.840	D	128,200	7,462	0.848	D	No	No
	4	SB	8,800	127,000	7,422	0.843	D	128,300	7,497	0.852	D	No	No

Deficient LOS indicated in **bold**.

⁽¹⁾ Peak hour volume (PHV) calculation = ADT x Peak Hour Percent x Directional Split x Truck Factor which is taken from Caltrans website.

Maximum level of service "E" capacity is assumed to be 2,200 vphpl for General Purpose Mainlanes.

Δ= Difference

V/C = Volume to Capacity Ratio

LOS = Level of Service

A significant impact occurs when project-related traffic causes a freeway segment to deteriorate from an acceptable LOS D or better to a deficient LOS E or F or if the project contributes to an existing deficiency.

TABLE 24, OPENING YEAR 2020 WITHOUT PROJECT FREEWAY MAINLINE SEGMENT LOS

I-15 Freeway Segment	No. Lanes	Direction	Capacity	ADT	Peak Hour % ⁽¹⁾	Directional Split ⁽¹⁾	Truck Factor ⁽¹⁾	PHV ⁽²⁾	V/C	LOS
	General									
Glen Helen Pkwy. to Sierra Ave.	4	NB	8,800	146,400	12.66%	51.93%	88.55%	8,524	0.969	E
	4	SB	8,800	146,800	12.00%	55.00%	88.55%	8,579	0.975	E
Sierra Ave. to Duncan Canyon Rd.	4	NB	8,800	142,300	12.66%	51.93%	88.55%	8,283	0.941	E
	4	SB	8,800	142,000	12.00%	55.00%	88.55%	8,298	0.943	E
Duncan Cayon Rd. to Beech Ave.	4	NB	8,800	142,300	12.66%	51.93%	88.55%	8,283	0.941	E
	4	SB	8,800	142,000	12.00%	55.00%	88.55%	8,298	0.943	E

Deficient LOS indicated in **bold**.

ADT = Average Daily Traffic

PHV = Peak Hour Volume (Highest Hour)

V/C = Volume to Capacity Ratio

LOS = Level of Service

Maximum level of service "E" capacity for General Purpose Mainlanes is assumed to be 2,200 vphpl.

⁽¹⁾ Data taken from Caltrans Count Data (2016)

⁽²⁾ Peak hour volume (PHV) calculation = ADT x Peak Hour Percent x Directional Split x Truck Factor which is taken from Caltrans website.

TABLE 25, OPENING YEAR 2020 WITH PROJECT FREEWAY MAINLINE SEGMENT LOS

I-15 Freeway Segment	No. Lanes	Direction	Capacity	Opening Year 2020 Without Project Conditions				Opening Year 2020 With Project Conditions				Sig. Impact?	
	General			ADT	PHV ⁽¹⁾	V/C	LOS	ADT	PHV ⁽¹⁾	V/C	LOS	AM	PM
Glen Helen Pkwy. to Sierra Ave.	4	NB	8,800	146,400	8,524	0.969	E	147,300	8,576	0.975	E	YES	YES
	4	SB	8,800	146,800	8,579	0.975	E	147,600	8,628	0.980	E	YES	YES
Sierra Ave. to Duncan Canyon Rd.	4	NB	8,800	142,300	8,283	0.941	E	143,200	8,334	0.947	E	YES	YES
	4	SB	8,800	142,000	8,298	0.943	E	142,900	8,353	0.949	E	YES	YES
Duncan Cayon Rd. to Beech Ave.	4	NB	8,800	142,300	8,283	0.941	E	143,500	8,352	0.949	E	YES	YES
	4	SB	8,800	142,000	8,298	0.943	E	143,300	8,373	0.951	E	YES	YES

Deficient LOS indicated in **bold**.

⁽¹⁾ Peak hour volume (PHV) calculation = ADT x Peak Hour Percent x Directional Split x Truck Factor which is taken from Caltrans website.

Maximum level of service "E" capacity is assumed to be 2,200 vphpl for General Purpose Mainlanes.

Δ= Difference

V/C = Volume to Capacity Ratio

LOS = Level of Service

A significant impact occurs when project-related traffic causes a freeway segment to deteriorate from an acceptable LOS D or better to a deficient LOS E or F or if the project contributes to an existing deficiency.

TABLE 26, HORIZON YEAR 2040 WITHOUT PROJECT FREEWAY MAINLINE SEGMENT LOS

I-15 Freeway Segment	No. Lanes General	Direction	Capacity	ADT ⁽²⁾	Peak Hour % ⁽¹⁾	Directional Split ⁽¹⁾	Truck Factor ⁽¹⁾	PHV ⁽³⁾	V/C	LOS
Glen Helen Pkwy. to Sierra Ave.	4	NB	8,800	203,500	12.66%	51.93%	88.55%	11,848	1.346	F
	4	SB	8,800	204,000	12.00%	55.00%	88.55%	11,925	1.355	F
Sierra Ave. to Duncan Canyon Rd.	4	NB	8,800	197,800	12.66%	51.93%	88.55%	11,513	1.308	F
	4	SB	8,800	197,400	12.00%	55.00%	88.55%	11,534	1.311	F
Duncan Cayon Rd. to Beech Ave.	4	NB	8,800	197,800	12.66%	51.93%	88.55%	11,513	1.308	F
	4	SB	8,800	197,400	12.00%	55.00%	88.55%	11,534	1.311	F

Deficient LOS indicated in **bold**.

ADT = Average Daily Traffic

PHV = Peak Hour Volume (Highest Hour)

⁽¹⁾ Data taken from Caltrans Count Data (2016)

⁽²⁾ Traffic volume is based on a 1.95% growth per year derived from 2016 Southern California Association of Governments (SCAG) Regional Transportation Plan.

⁽³⁾ Peak hour volume (PHV) calculation = ADT x Peak Hour Percent x Directional Split x Truck Factor which is taken from Caltrans website.

TABLE 27, HORIZON YEAR 2040 WITH PROJECT FREEWAY MAINLINE SEGMENT LOS

I-15 Freeway Segment	No. Lanes General	Direction	Capacity	Horizon Year 2040 Without Project Conditions				Horizon Year 2040 With Project Conditions				Sig. Impact?	
				ADT	PHV ⁽¹⁾	V/C	LOS	ADT	PHV ⁽¹⁾	V/C	LOS	AM	PM
Glen Helen Pkwy. to Sierra Ave.	4	NB	8,800	203,500	11,848	1.346	F	204,400	11,900	1.352	F	YES	YES
	4	SB	8,800	204,000	11,925	1.355	F	204,900	11,974	1.361	F	YES	YES
Sierra Ave. to Duncan Canyon Rd.	4	NB	8,800	197,800	11,513	1.308	F	198,600	11,564	1.314	F	YES	YES
	4	SB	8,800	197,400	11,534	1.311	F	198,300	11,589	1.317	F	YES	YES
Duncan Cayon Rd. to Beech Ave.	4	NB	8,800	197,800	11,513	1.308	F	198,900	11,582	1.316	F	YES	YES
	4	SB	8,800	197,400	11,534	1.311	F	198,600	11,609	1.319	F	YES	YES

Deficient LOS indicated in **bold**.

⁽¹⁾ Peak hour volume (PHV) calculation = ADT x Peak Hour Percent x Directional Split x Truck Factor which is taken from Caltrans website.

Maximum level of service "E" capacity is assumed to be 2,200 vphpl for General Purpose Mainlanes.

Δ = Difference

V/C = Volume to Capacity Ratio

LOS = Level of Service

HOV = High Occupancy Vehicle

A significant impact occurs when project-related traffic causes a freeway segment to deteriorate from an acceptable LOS D or better to a deficient LOS E or F or if the project contributes to an existing deficiency.

As shown in **Table 25** and **Table 27**, Interstate 15 between Glen Helen Parkway and Beech Avenue is significantly impacted by the project under the Opening Year 2020 With Project conditions and Horizon Year 2040 With Project conditions. Improvements to the I-15 corridor are not planned or funded by Caltrans at this time. Therefore, mitigation measures at these locations have not been proposed. As such, impacts at these locations are considered significant and unavoidable.

11 FREEWAY RAMP MERGE/DIVERGE ANALYSIS

This section of the report evaluates freeway ramp merge and diverge operations at the I-15/Sierra Avenue interchange. Consistent with the City of Fontana Traffic Impact Study Guidelines, freeway on and off ramps with more than 50 directional peak hour project trips were included in this analysis. The proposed project contributes more than 50 (non-PCE) peak hour trips to the northbound and southbound ramps at Sierra Avenue. As such, the following ramp merge/diverge areas were analyzed:

- I-15 NB Off-Ramp to Sierra Avenue
- I-15 NB On-Ramp from Sierra Avenue
- I-15 SB Off-Ramp to Sierra Avenue
- I-15 SB On-Ramp from Sierra Avenue

The ramp merge/diverge areas were evaluated for Existing, Existing With Project, Opening Year 2020, Opening Year 2020 With Project, Horizon Year 2040, and Horizon Year 2040 With Project conditions and the results of this analysis are presented in **Tables 28 - 33**. Under Existing and Existing With Project conditions, freeway on and off ramps at Sierra Avenue are currently operating at LOS C, D, and E. In Opening Year 2020 and Horizon Year 2040 Without and With Project conditions, freeway on and off ramps analyzed are forecast to operate at a deficient LOS F.

At Caltrans facilities, LOS D is considered acceptable and LOS E or F is considered deficient. A significant impact occurs when project-related traffic causes a freeway ramp to deteriorate from an acceptable LOS (D or better) to a deficient LOS (E or F) or if the project contributes to an existing deficiency.

Freeway ramp merge/diverge analysis worksheets are provided in **Appendix J**.

TABLE 28, EXISTING FREEWAY RAMP MERGE/DIVERGE LOS

Study Freeway Ramp	Analysis Type	Freeway Lanes	Ramp Lanes	Existing Conditions	
				AM Peak Hour	PM Peak Hour
				Density - LOS	Density - LOS
1. I-15 NB Off-Ramp to Sierra Ave.	Diverge	4	1	35.8 - E	38.7 - E
2. I-15 NB On-Ramp from Sierra Ave.	Merge	4	1	27.0 - C	28.6 - D
3. I-15 SB Off-Ramp to Sierra Ave.	Diverge	4	1	37.0 - E	35.8 - E
4. I-15 SB On-Ramp from Sierra Ave.	Merge	4	1	35.1 - E	30.4 - D

Deficient LOS indicated in **bold**.

NB=Northbound, SB=Southbound

Density is measured by passenger cars per mile per lane (pc/mi/ln).

LOS = Level of Service

TABLE 29, EXISTING WITH PROJECT FREEWAY RAMP MERGE/DIVERGE LOS

Study Freeway Ramp	Analysis Type	Freeway Lanes	Ramp Lanes	Existing Conditions		Existing With Project Conditions		Significant Impact?	
				AM Peak Hour	PM Peak Hour	AM Peak Hour	PM Peak Hour	AM	PM
				Density - LOS	Density - LOS	Density - LOS	Density - LOS		
1. I-15 NB Off-Ramp to Sierra Ave.	Diverge	4	1	35.8 - E	38.7 - E	36.3 - E	39.0 - E	YES	YES
2. I-15 NB On-Ramp from Sierra Ave.	Merge	4	1	27.0 - C	28.6 - D	27.2 - C	29.1 - D	NO	NO
3. I-15 SB Off-Ramp to Sierra Ave.	Diverge	4	1	37.0 - E	35.8 - E	37.5 - E	36.1 - E	YES	YES
4. I-15 SB On-Ramp from Sierra Ave.	Merge	4	1	35.1 - E	30.4 - D	35.2 - E	31.0 - D	YES	NO

Deficient LOS indicated in **bold**.

NB=Northbound, SB=Southbound

Density is measured by passenger cars per mile per lane (pc/mi/ln).

LOS = Level of Service

A significant impact occurs when project-related traffic causes a freeway ramp to deteriorate from an acceptable LOS D or better to a deficient LOS E or F or if the project contributes to an existing deficiency.

TABLE 30, OPENING YEAR 2020 WITHOUT PROJECT FREEWAY RAMP MERGE/DIVERGE LOS

Study Freeway Ramp	Analysis Type	Freeway Lanes	Ramp Lanes	Opening Year 2020 Without Project Conditions	
				AM Peak Hour	PM Peak Hour
				Density - LOS	Density - LOS
1. I-15 NB Off-Ramp to Sierra Ave.	Diverge	4	1	40.3 - F	44.4 - F
2. I-15 NB On-Ramp from Sierra Ave.	Merge	4	1	34.4 - F	34.7 - F
3. I-15 SB Off-Ramp to Sierra Ave.	Diverge	4	1	43.6 - F	44.0 - F
4. I-15 SB On-Ramp from Sierra Ave.	Merge	4	1	40.9 - F	34.2 - F

Deficient LOS indicated in **bold**.

NB=Northbound, SB=Southbound

Density is measured by passenger cars per mile per lane (pc/mi/ln).

LOS = Level of Service

TABLE 31, OPENING YEAR 2020 WITH PROJECT FREEWAY RAMP MERGE/DIVERGE LOS

Study Freeway Ramp	Analysis Type	Freeway Lanes	Ramp Lanes	Opening Year 2020 Without Project Conditions		Opening Year 2020 With Project Conditions		Significant Impact?	
				AM Peak Hour	PM Peak Hour	AM Peak Hour	PM Peak Hour	AM	PM
				Density - LOS	Density - LOS	Density - LOS	Density - LOS		
1. I-15 NB Off-Ramp to Sierra Ave.	Diverge	4	1	40.3 - F	44.4 - F	40.8 - F	44.7 - F	YES	YES
2. I-15 NB On-Ramp from Sierra Ave.	Merge	4	1	34.4 - F	34.7 - F	34.5 - F	35.2 - F	YES	YES
3. I-15 SB Off-Ramp to Sierra Ave.	Diverge	4	1	43.6 - F	44.0 - F	44.1 - F	44.3 - F	YES	YES
4. I-15 SB On-Ramp from Sierra Ave.	Merge	4	1	40.9 - F	34.2 - F	41.1 - F	34.8 - F	YES	YES

Deficient LOS indicated in **bold**.

NB=Northbound, SB=Southbound

Density is measured by passenger cars per mile per lane (pc/mi/ln).

LOS = Level of Service

A significant impact occurs when project-related traffic causes a freeway ramp to deteriorate from an acceptable LOS D or better to a deficient LOS E or F or if the project contributes to an existing deficiency.

TABLE 32, HORIZON YEAR 2040 WITHOUT PROJECT FREEWAY RAMP MERGE/DIVERGE LOS

Study Freeway Ramp	Analysis Type	Freeway Lanes	Ramp Lanes	Horizon Year 2040 Without Project Conditions	
				AM Peak Hour	PM Peak Hour
				Density - LOS	Density - LOS
1. I-15 NB Off-Ramp to Sierra Ave.	Diverge	4	1	69.1 - F	69.1 - F
2. I-15 NB On-Ramp from Sierra Ave.	Merge	4	1	50.4 - F	51.5 - F
3. I-15 SB Off-Ramp to Sierra Ave.	Diverge	4	1	73.1 - F	73.1 - F
4. I-15 SB On-Ramp from Sierra Ave.	Merge	4	1	55.4 - F	46.6 - F

Deficient LOS indicated in **bold**.

NB=Northbound, SB=Southbound

Density is measured by passenger cars per mile per lane (pc/mi/ln).

LOS = Level of Service

TABLE 33, HORIZON YEAR 2040 WITH PROJECT FREEWAY RAMP MERGE/DIVERGE LOS

Study Freeway Ramp	Analysis Type	Freeway Lanes	Ramp Lanes	Horizon Year 2040 Without Project Conditions		Horizon Year 2040 With Project Conditions		Significant Impact?	
				AM Peak Hour	PM Peak Hour	AM Peak Hour	PM Peak Hour	AM	PM
				Density - LOS	Density - LOS	Density - LOS	Density - LOS		
1. I-15 NB Off-Ramp to Sierra Ave.	Diverge	4	1	69.1 - F	69.1 - F	69.6 - F	69.6 - F	YES	YES
2. I-15 NB On-Ramp from Sierra Ave.	Merge	4	1	50.4 - F	51.5 - F	50.5 - F	52.0 - F	YES	YES
3. I-15 SB Off-Ramp to Sierra Ave.	Diverge	4	1	73.1 - F	73.1 - F	73.6 - F	73.6 - F	YES	YES
4. I-15 SB On-Ramp from Sierra Ave.	Merge	4	1	55.4 - F	46.6 - F	55.5 - F	47.2 - F	YES	YES

Deficient LOS indicated in **bold**.

NB=Northbound, SB=Southbound

Density is measured by passenger cars per mile per lane (pc/mi/ln).

LOS = Level of Service

A significant impact occurs when project-related traffic causes a freeway ramp to deteriorate from an acceptable LOS D or better to a deficient LOS E or F or if the project contributes to an existing deficiency.

As shown in **Table 29**, **Table 31** and **Table 33**, Interstate 15 northbound and southbound on/off ramps at Sierra Avenue are significantly impacted by the project under Existing With Project, Opening Year 2020 With Project and Horizon Year 2040 With Project conditions. Improvements at this freeway interchange and/or ramps are not planned or funded by Caltrans at this time. Therefore, mitigation measures at these locations have not been proposed. As such, impacts at these locations are considered significant and unavoidable.

12 FINDINGS AND RECOMMENDATIONS

This study analyzes the forecast traffic conditions associated with the proposed I-15 Logistics Center project located in the County of San Bernardino within the City of Fontana's Sphere of Influence. The project site occupies approximately 75.76 acres southeast of Lytle Creek Road between Duncan Canyon Road and Sierra Avenue.

The project proposes to construct a 1,175,720 square foot warehouse (ITE Land Use Code 150).

The proposed project is forecast to generate approximately 2,046 vehicle trips per day, with approximately 200 trips occurring during the AM peak hour and approximately 223 trips occurring during the PM peak hour. To account for the truck trips generated by the project, vehicular trips have been converted to passenger car equivalent (PCE) trips. Once converted to PCE's, the proposed project is forecast to generate 3,122 PCE trips per day with approximately 305 trips occurring during the AM peak hour and approximately 340 trips occurring during the PM peak hour.

The City of Fontana's designated sphere of influence includes most, but not all of the project site. Therefore, an expansion of the City's sphere of influence is proposed to include the entire project area. The proposed annexation would include approximately 22 parcels, inclusive of the warehouse site, and portions of the road right-of-way for Lytle Creek Road, Sierra Avenue, and I-15. **This document addresses the potential traffic impacts of the proposed warehouse building.**

The project will also include the construction of new Lytle Creek Road to Sierra Avenue extension from the property's northern boundary and continuing northeast for approximately 0.42 miles. All "With Project" scenarios for this traffic study includes this partial realignment. In addition, the southwest portion of Lytle Creek Road is also planned to be realigned with the existing Coyote Canyon Road and is assumed to be constructed by Opening Year by other parties.

Existing With Project Conditions - Summary of Impacts & Mitigation

The results of the Existing With Project conditions show the following study intersections are forecast to operate at deficient levels of service (LOS D, E or F) with the addition of project-related traffic volumes:

- Sierra Avenue / I-15 Southbound Ramps (LOS F in AM peak hour)
- Sierra Avenue / Riverside Avenue (LOS F in AM & PM peak hour)

According to the *City of Fontana's Traffic Impact Analysis Guidelines* significance criteria, the following intersection would result in a direct significant impact and mitigation is required:

- **Sierra Avenue / Riverside Avenue (Direct Impact) – See Table 34**

The results of the roadway segment analysis along Lytle Creek Road show that all study segments are forecast to operate at acceptable levels of service (C or better) under Existing With Project conditions. Therefore, no significant impacts have been identified and no mitigation measures are required on study roadway segments.

Opening Year 2020 With Project Conditions - Summary of Impacts & Mitigation

The results of the analysis under Opening Year 2020 With Project conditions show the following study intersections are forecast to operate at deficient levels of service (LOS D, E or F) with the addition of project-related traffic volumes:

- Sierra Avenue / I-15 Southbound Ramps (LOS F in AM peak hour)
- Sierra Avenue / I-15 Northbound Ramps (LOS F in PM peak hour)
- Sierra Avenue / Riverside Avenue (LOS D in AM & PM peak hour)

According to the *City of Fontana's Traffic Impact Analysis Guidelines* significance criteria, the following intersections would result in a near-term cumulative significant impact and mitigation is required:

- **Sierra Avenue / I-15 NB Ramps (Near-Term Cumulative Impact) – See Table 34**

The results of the roadway segment analysis along Lytle Creek Road show that all study segments are forecast to operate at acceptable levels of service (C or better) under Opening Year 2020 With Project conditions. Therefore, no significant impacts have been identified and no mitigation measures are required.

Horizon Year 2040 With Project Conditions - Summary of Impacts & Mitigation

The results of the analysis under Horizon Year 2040 With Project conditions show the following study intersections are forecast to operate at deficient levels of service (LOS D, E or F) with the addition of project-related traffic volumes:

- Coyote Canyon Road / Duncan Canyon Road (LOS D in the PM peak hour)
- Sierra Avenue / I-15 SB Ramps (LOS F in AM peak hour)
- Sierra Avenue / I-15 NB Ramps (LOS F in AM & PM peak hour)
- Sierra Avenue / Riverside Avenue (LOS D in the PM peak hour)

According to the *City of Fontana's Traffic Impact Analysis Guidelines* significance criteria, the following intersections would result in a long-term cumulative significant impact and mitigation is required:

- **Sierra Avenue / I-15 SB Ramps (Long-Term Cumulative Impact) – See Table 34**
- **Sierra Avenue / I-15 NB Ramps (Long-Term Cumulative Impact) – See Table 34**

The results of the roadway segment analysis along Lytle Creek Road show that all study segments are forecast to operate at acceptable levels of service (C or better) under Horizon Year 2040 With Project conditions. Therefore, no significant impacts have been identified and no mitigation measures are required.

Table 34 summarizes the recommended mitigation measures and fair share contributions toward the intersection improvements.

TABLE 34, SUMMARY OF PEAK HOUR INTERSECTION OPERATIONS WITH MITIGATION

Int. #	Intersection	Peak Hour	Without Project	With Project	Recommended Mitigation	With Project With Mitigation	Project Responsibility (%)
			Delay ⁽¹⁾ – LOS	Delay ⁽¹⁾ – LOS		Delay ⁽¹⁾ – LOS	
Existing With Project Conditions							
9	Riverside Avenue / Sierra Avenue	AM	60.8 - E	70.3 - F	The City of Fontana is planning to construct an additional northbound lane on Sierra Avenue and install a new traffic signal. Current construction schedule is unknown, however plans have been developed and construction may occur in 2020. No additional mitigation is required of the project applicant.	17.9 – B	0%
		PM	>80.0 - F	>80.0 - F		22.7 – C	0%
Opening Year 2020 With Project Conditions							
8	Sierra Avenue / I-15 NB Ramps	PM	>80.0 - F	>80.0 - F	(2)	(2)	(2)
Horizon Year 2040 With Project Conditions							
7	Sierra Ave / I-15 SB Ramps	AM	>80.0 – F	>80.0 – F	(2)	(2)	(2)
8	Sierra Ave / I-15 NB Ramps	AM	74.2 – E	>80.0 – F	(2)	(2)	(2)
		PM	>80.0 – F	>80.0 – F			

(1) Seconds of delay per vehicle.

(2) There are no specific improvements identified at the I-15/Sierra Ave. interchange by Caltrans or SB County, therefore, no mitigation is proposed by the project. The project-related impact at this location is considered significant and unavoidable.

Freeway Mainline & Ramp Analysis Summary

Under Existing and Existing With Project conditions, all three study freeway mainline segments are operating at LOS D. In Opening Year 2020 conditions and Horizon Year 2040 conditions with and without the project, freeway segments analyzed are forecast to operate at LOS E and F respectively.

Freeway on and off ramps at Sierra Avenue are currently operating at LOS C, D, and E for Existing and Existing With Project conditions. In Opening Year 2020 and Horizon Year 2040 Without and With Project conditions, freeway on and off ramps analyzed are forecast to operate at LOS F.

Improvements at study area freeway mainline segments and freeway on/off ramps are not planned or funded by Caltrans at this time. Therefore, mitigation measures at these locations have not been proposed. As such, impacts at these locations are considered significant and unavoidable.

Appendix A: Count Data & Signal Warrants

This page intentionally left blank

County of San Bernardino
 N/S: Coyote Canyon Road
 E/W: Duncan Canyon Road
 Weather: Clear

File Name : 01_CSB_Coyote Cyn_Duncan Cyn AM
 Site Code : 12218022
 Start Date : 1/24/2018
 Page No : 1

Groups Printed- Passenger Vehicles - Large 2 Axle Vehicles - 3 Axle Vehicles - 4+ Axle Trucks

Start Time	Coyote Canyon Road Southbound				Duncan Canyon Road Westbound				Coyote Canyon Road Northbound				Duncan Canyon Road Eastbound				Int. Total
	Left	Thru	Right	App. Total	Left	Thru	Right	App. Total	Left	Thru	Right	App. Total	Left	Thru	Right	App. Total	
07:00 AM	13	0	2	15	9	20	2	31	1	1	27	29	2	56	0	58	133
07:15 AM	17	2	2	21	7	21	2	30	0	0	30	30	0	76	1	77	158
07:30 AM	16	0	4	20	9	19	2	30	1	0	27	28	2	71	0	73	151
07:45 AM	10	0	1	11	6	27	5	38	1	1	15	17	2	60	2	64	130
Total	56	2	9	67	31	87	11	129	3	2	99	104	6	263	3	272	572
08:00 AM	12	2	1	15	4	31	4	39	3	2	15	20	5	71	3	79	153
08:15 AM	11	0	2	13	7	23	8	38	1	0	21	22	4	43	1	48	121
08:30 AM	9	1	0	10	10	25	7	42	0	0	12	12	4	42	2	48	112
08:45 AM	6	1	2	9	6	15	3	24	0	0	16	16	1	32	2	35	84
Total	38	4	5	47	27	94	22	143	4	2	64	70	14	188	8	210	470
Grand Total	94	6	14	114	58	181	33	272	7	4	163	174	20	451	11	482	1042
Apprch %	82.5	5.3	12.3		21.3	66.5	12.1		4	2.3	93.7		4.1	93.6	2.3		
Total %	9	0.6	1.3	10.9	5.6	17.4	3.2	26.1	0.7	0.4	15.6	16.7	1.9	43.3	1.1	46.3	
Passenger Vehicles	94	6	13	113	57	178	33	268	7	4	161	172	20	449	11	480	1033
% Passenger Vehicles	100	100	92.9	99.1	98.3	98.3	100	98.5	100	100	98.8	98.9	100	99.6	100	99.6	99.1
Large 2 Axle Vehicles	0	0	1	1	1	3	0	4	0	0	2	2	0	2	0	2	9
% Large 2 Axle Vehicles	0	0	7.1	0.9	1.7	1.7	0	1.5	0	0	1.2	1.1	0	0.4	0	0.4	0.9
3 Axle Vehicles	0	0	0	0	0	0	0	0	0	0	0	0	0	0	0	0	0
% 3 Axle Vehicles	0	0	0	0	0	0	0	0	0	0	0	0	0	0	0	0	0
4+ Axle Trucks	0	0	0	0	0	0	0	0	0	0	0	0	0	0	0	0	0
% 4+ Axle Trucks	0	0	0	0	0	0	0	0	0	0	0	0	0	0	0	0	0

Start Time	Coyote Canyon Road Southbound				Duncan Canyon Road Westbound				Coyote Canyon Road Northbound				Duncan Canyon Road Eastbound				Int. Total
	Left	Thru	Right	App. Total	Left	Thru	Right	App. Total	Left	Thru	Right	App. Total	Left	Thru	Right	App. Total	
Peak Hour Analysis From 07:00 AM to 08:45 AM - Peak 1 of 1																	
Peak Hour for Entire Intersection Begins at 07:15 AM																	
07:15 AM	17	2	2	21	7	21	2	30	0	0	30	30	0	76	1	77	158
07:30 AM	16	0	4	20	9	19	2	30	1	0	27	28	2	71	0	73	151
07:45 AM	10	0	1	11	6	27	5	38	1	1	15	17	2	60	2	64	130
08:00 AM	12	2	1	15	4	31	4	39	3	2	15	20	5	71	3	79	153
Total Volume	55	4	8	67	26	98	13	137	5	3	87	95	9	278	6	293	592
% App. Total	82.1	6	11.9		19	71.5	9.5		5.3	3.2	91.6		3.1	94.9	2		
PHF	.809	.500	.500	.798	.722	.790	.650	.878	.417	.375	.725	.792	.450	.914	.500	.927	.937

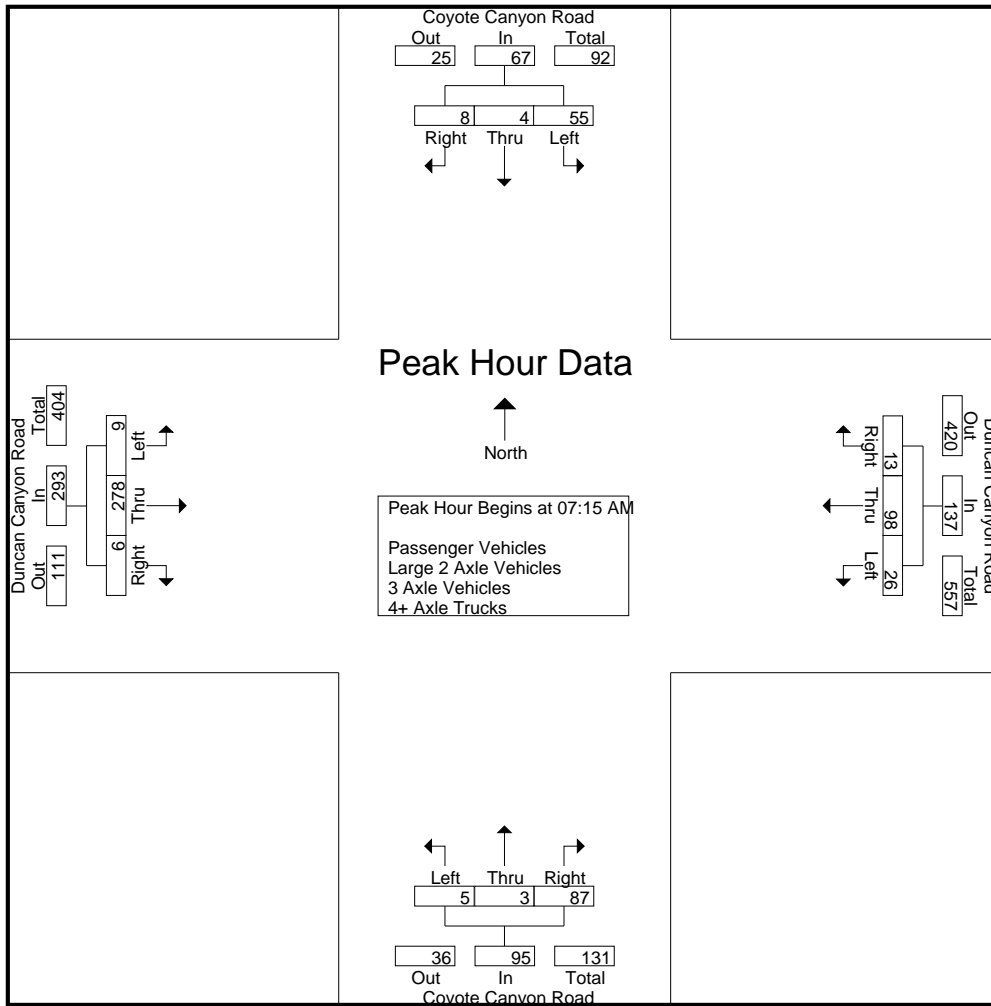

Peak Hour Analysis From 07:00 AM to 08:45 AM - Peak 1 of 1
 Peak Hour for Each Approach Begins at:

	07:00 AM				07:45 AM				07:00 AM				07:15 AM			
+0 mins.	13	0	2	15	6	27	5	38	1	1	27	29	0	76	1	77
+15 mins.	17	2	2	21	4	31	4	39	0	0	30	30	2	71	0	73
+30 mins.	16	0	4	20	7	23	8	38	1	0	27	28	2	60	2	64
+45 mins.	10	0	1	11	10	25	7	42	1	1	15	17	5	71	3	79
Total Volume	56	2	9	67	27	106	24	157	3	2	99	104	9	278	6	293
% App. Total	83.6	3	13.4		17.2	67.5	15.3		2.9	1.9	95.2		3.1	94.9	2	
PHF	.824	.250	.563	.798	.675	.855	.750	.935	.750	.500	.825	.867	.450	.914	.500	.927

County of San Bernardino
 N/S: Coyote Canyon Road
 E/W: Duncan Canyon Road
 Weather: Clear

File Name : 01_CSB_Coyote Cyn_Duncan Cyn AM
 Site Code : 12218022
 Start Date : 1/24/2018
 Page No : 1

Groups Printed- Passenger Vehicles

Start Time	Coyote Canyon Road Southbound				Duncan Canyon Road Westbound				Coyote Canyon Road Northbound				Duncan Canyon Road Eastbound				Int. Total
	Left	Thru	Right	App. Total	Left	Thru	Right	App. Total	Left	Thru	Right	App. Total	Left	Thru	Right	App. Total	
07:00 AM	13	0	1	14	9	20	2	31	1	1	27	29	2	56	0	58	132
07:15 AM	17	2	2	21	7	21	2	30	0	0	30	30	0	75	1	76	157
07:30 AM	16	0	4	20	9	19	2	30	1	0	26	27	2	71	0	73	150
07:45 AM	10	0	1	11	5	25	5	35	1	1	15	17	2	60	2	64	127
Total	56	2	8	66	30	85	11	126	3	2	98	103	6	262	3	271	566
08:00 AM	12	2	1	15	4	31	4	39	3	2	15	20	5	70	3	78	152
08:15 AM	11	0	2	13	7	23	8	38	1	0	21	22	4	43	1	48	121
08:30 AM	9	1	0	10	10	24	7	41	0	0	12	12	4	42	2	48	111
08:45 AM	6	1	2	9	6	15	3	24	0	0	15	15	1	32	2	35	83
Total	38	4	5	47	27	93	22	142	4	2	63	69	14	187	8	209	467
Grand Total	94	6	13	113	57	178	33	268	7	4	161	172	20	449	11	480	1033
Apprch %	83.2	5.3	11.5		21.3	66.4	12.3		4.1	2.3	93.6		4.2	93.5	2.3		
Total %	9.1	0.6	1.3	10.9	5.5	17.2	3.2	25.9	0.7	0.4	15.6	16.7	1.9	43.5	1.1	46.5	

Start Time	Coyote Canyon Road Southbound				Duncan Canyon Road Westbound				Coyote Canyon Road Northbound				Duncan Canyon Road Eastbound				Int. Total
	Left	Thru	Right	App. Total	Left	Thru	Right	App. Total	Left	Thru	Right	App. Total	Left	Thru	Right	App. Total	
Peak Hour Analysis From 07:15 AM to 08:00 AM - Peak 1 of 1																	
Peak Hour for Entire Intersection Begins at 07:15 AM																	
07:15 AM	17	2	2	21	7	21	2	30	0	0	30	30	0	75	1	76	157
07:30 AM	16	0	4	20	9	19	2	30	1	0	26	27	2	71	0	73	150
07:45 AM	10	0	1	11	5	25	5	35	1	1	15	17	2	60	2	64	127
08:00 AM	12	2	1	15	4	31	4	39	3	2	15	20	5	70	3	78	152
Total Volume	55	4	8	67	25	96	13	134	5	3	86	94	9	276	6	291	586
% App. Total	82.1	6	11.9		18.7	71.6	9.7		5.3	3.2	91.5		3.1	94.8	2.1		
PHF	.809	.500	.500	.798	.694	.774	.650	.859	.417	.375	.717	.783	.450	.920	.500	.933	.933

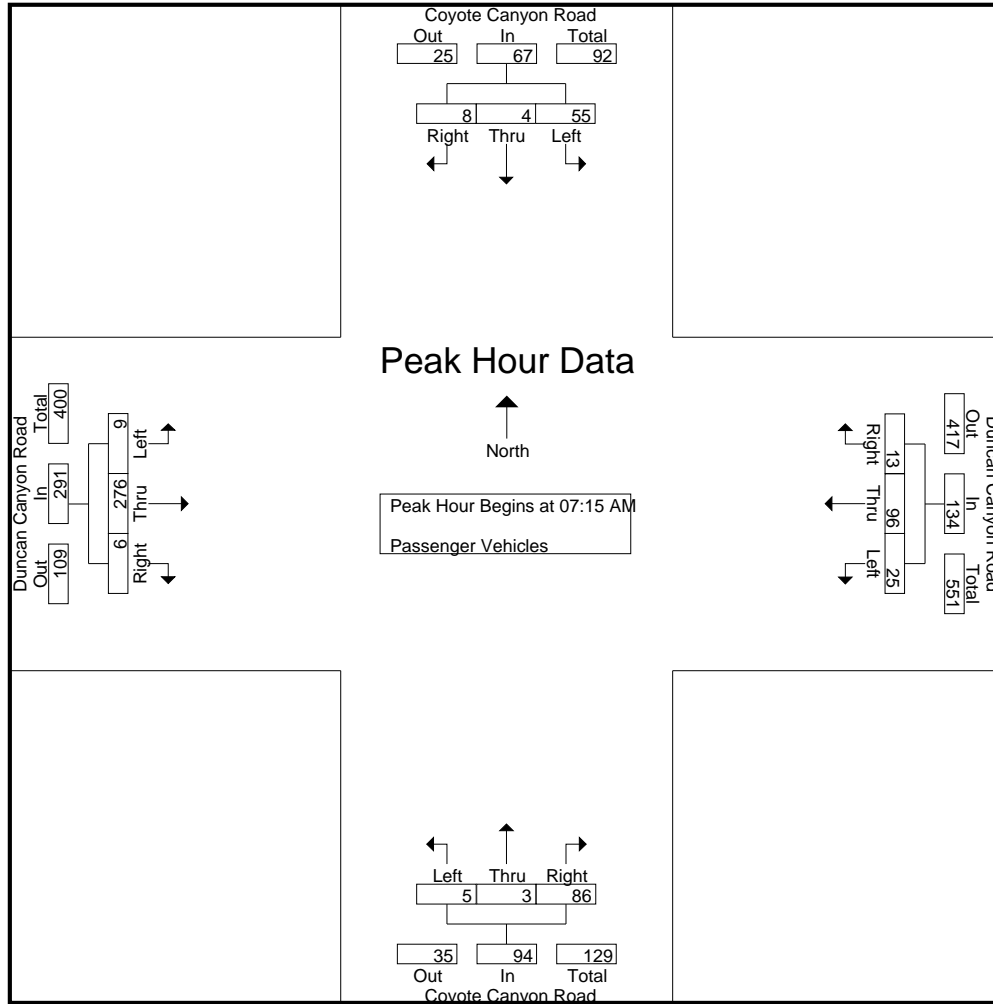

Peak Hour Analysis From 07:15 AM to 08:00 AM - Peak 1 of 1
 Peak Hour for Each Approach Begins at:

	07:15 AM				07:15 AM				07:15 AM				07:15 AM			
+0 mins.	17	2	2	21	7	21	2	30	0	0	30	30	0	75	1	76
+15 mins.	16	0	4	20	9	19	2	30	1	0	26	27	2	71	0	73
+30 mins.	10	0	1	11	5	25	5	35	1	1	15	17	2	60	2	64
+45 mins.	12	2	1	15	4	31	4	39	3	2	15	20	5	70	3	78
Total Volume	55	4	8	67	25	96	13	134	5	3	86	94	9	276	6	291
% App. Total	82.1	6	11.9		18.7	71.6	9.7		5.3	3.2	91.5		3.1	94.8	2.1	
PHF	.809	.500	.500	.798	.694	.774	.650	.859	.417	.375	.717	.783	.450	.920	.500	.933

County of San Bernardino
 N/S: Coyote Canyon Road
 E/W: Duncan Canyon Road
 Weather: Clear

File Name : 01_CSB_Coyote Cyn_Duncan Cyn AM
 Site Code : 12218022
 Start Date : 1/24/2018
 Page No : 1

Groups Printed- Large 2 Axle Vehicles

Start Time	Coyote Canyon Road Southbound				Duncan Canyon Road Westbound				Coyote Canyon Road Northbound				Duncan Canyon Road Eastbound				Int. Total	
	Left	Thru	Right	App. Total	Left	Thru	Right	App. Total	Left	Thru	Right	App. Total	Left	Thru	Right	App. Total		
07:00 AM	0	0	1	1	0	0	0	0	0	0	0	0	0	0	0	0	0	1
07:15 AM	0	0	0	0	0	0	0	0	0	0	0	0	0	1	0	0	0	1
07:30 AM	0	0	0	0	0	0	0	0	0	0	1	1	0	0	0	0	0	1
07:45 AM	0	0	0	0	1	2	0	3	0	0	0	0	0	0	0	0	0	3
Total	0	0	1	1	1	2	0	3	0	0	1	1	0	1	0	0	0	6
08:00 AM	0	0	0	0	0	0	0	0	0	0	0	0	0	1	0	0	0	1
08:15 AM	0	0	0	0	0	0	0	0	0	0	0	0	0	0	0	0	0	0
08:30 AM	0	0	0	0	0	1	0	1	0	0	0	0	0	0	0	0	0	1
08:45 AM	0	0	0	0	0	0	0	0	0	0	1	1	0	0	0	0	0	1
Total	0	0	0	0	0	1	0	1	0	0	1	1	0	1	0	0	0	3
Grand Total	0	0	1	1	1	3	0	4	0	0	2	2	0	2	0	0	0	9
Apprch %	0	0	100		25	75	0		0	0	100		0	100	0			
Total %	0	0	11.1	11.1	11.1	33.3	0	44.4	0	0	22.2	22.2	0	22.2	0	0	22.2	

Start Time	Coyote Canyon Road Southbound				Duncan Canyon Road Westbound				Coyote Canyon Road Northbound				Duncan Canyon Road Eastbound				Int. Total	
	Left	Thru	Right	App. Total	Left	Thru	Right	App. Total	Left	Thru	Right	App. Total	Left	Thru	Right	App. Total		
Peak Hour Analysis From 07:15 AM to 08:00 AM - Peak 1 of 1																		
Peak Hour for Entire Intersection Begins at 07:15 AM																		
07:15 AM	0	0	0	0	0	0	0	0	0	0	0	0	0	1	0	0	0	1
07:30 AM	0	0	0	0	0	0	0	0	0	0	1	1	0	0	0	0	0	1
07:45 AM	0	0	0	0	1	2	0	3	0	0	0	0	0	0	0	0	0	3
08:00 AM	0	0	0	0	0	0	0	0	0	0	0	0	0	1	0	0	0	1
Total Volume	0	0	0	0	1	2	0	3	0	0	1	1	0	2	0	0	0	6
% App. Total	0	0	0		33.3	66.7	0		0	0	100		0	100	0			
PHF	.000	.000	.000	.000	.250	.250	.000	.250	.000	.000	.250	.250	.000	.500	.000	.500	.500	.500

County of San Bernardino
 N/S: Coyote Canyon Road
 E/W: Duncan Canyon Road
 Weather: Clear

File Name : 01_CSB_Coyote Cyn_Duncan Cyn AM
 Site Code : 12218022
 Start Date : 1/24/2018
 Page No : 2

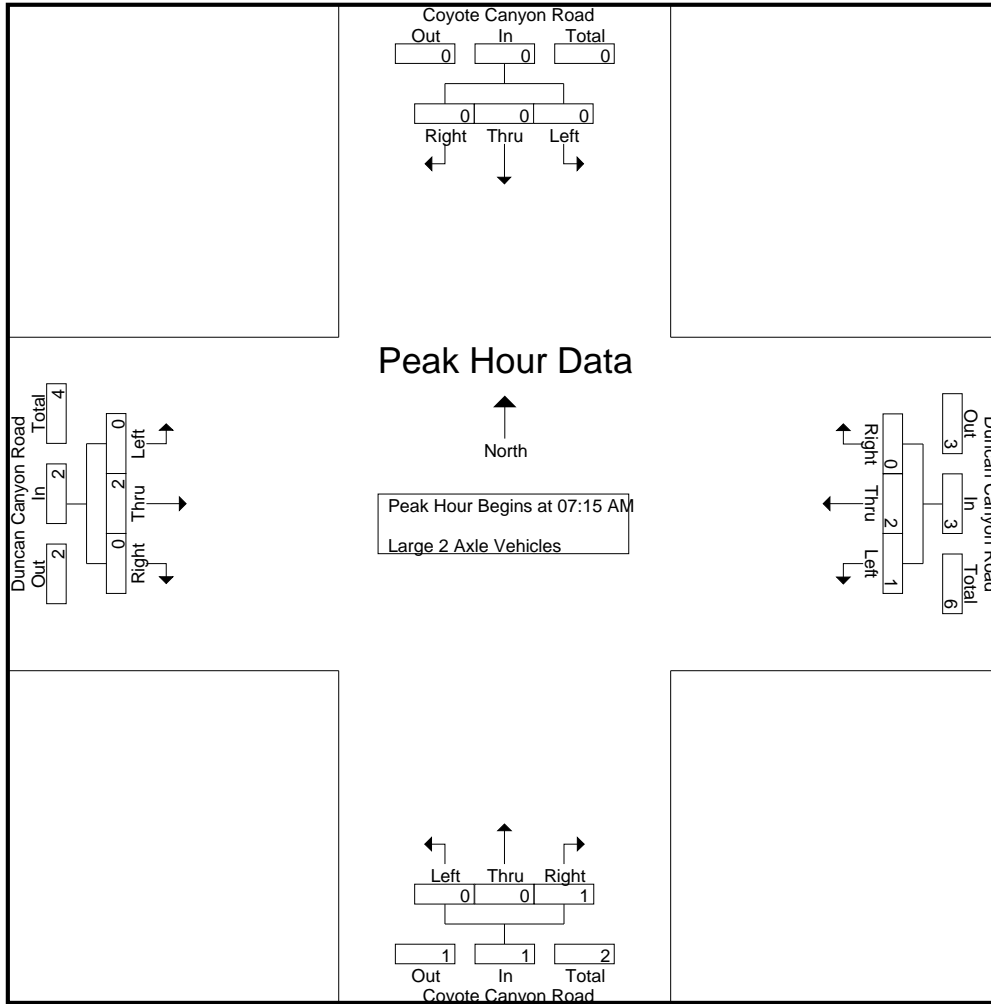

Peak Hour Analysis From 07:15 AM to 08:00 AM - Peak 1 of 1
 Peak Hour for Each Approach Begins at:

	07:15 AM				07:15 AM				07:15 AM				07:15 AM			
+0 mins.	0	0	0	0	0	0	0	0	0	0	0	0	0	1	0	1
+15 mins.	0	0	0	0	0	0	0	0	0	0	1	1	0	0	0	0
+30 mins.	0	0	0	0	1	2	0	3	0	0	0	0	0	0	0	0
+45 mins.	0	0	0	0	0	0	0	0	0	0	0	0	0	1	0	1
Total Volume	0	0	0	0	1	2	0	3	0	0	1	1	0	2	0	2
% App. Total	0	0	0	0	33.3	66.7	0	0	0	0	100	0	0	100	0	0
PHF	.000	.000	.000	.000	.250	.250	.000	.250	.000	.000	.250	.250	.000	.500	.000	.500

County of San Bernardino
 N/S: Coyote Canyon Road
 E/W: Duncan Canyon Road
 Weather: Clear

File Name : 01_CSB_Coyote Cyn_Duncan Cyn AM
 Site Code : 12218022
 Start Date : 1/24/2018
 Page No : 1

Groups Printed- 3 Axle Vehicles

Start Time	Coyote Canyon Road Southbound				Duncan Canyon Road Westbound				Coyote Canyon Road Northbound				Duncan Canyon Road Eastbound				Int. Total
	Left	Thru	Right	App. Total	Left	Thru	Right	App. Total	Left	Thru	Right	App. Total	Left	Thru	Right	App. Total	
07:00 AM	0	0	0	0	0	0	0	0	0	0	0	0	0	0	0	0	0
07:15 AM	0	0	0	0	0	0	0	0	0	0	0	0	0	0	0	0	0
07:30 AM	0	0	0	0	0	0	0	0	0	0	0	0	0	0	0	0	0
07:45 AM	0	0	0	0	0	0	0	0	0	0	0	0	0	0	0	0	0
Total	0	0	0	0	0	0	0	0	0	0	0	0	0	0	0	0	0
08:00 AM	0	0	0	0	0	0	0	0	0	0	0	0	0	0	0	0	0
08:15 AM	0	0	0	0	0	0	0	0	0	0	0	0	0	0	0	0	0
08:30 AM	0	0	0	0	0	0	0	0	0	0	0	0	0	0	0	0	0
08:45 AM	0	0	0	0	0	0	0	0	0	0	0	0	0	0	0	0	0
Total	0	0	0	0	0	0	0	0	0	0	0	0	0	0	0	0	0
Grand Total	0	0	0	0	0	0	0	0	0	0	0	0	0	0	0	0	0
Apprch %	0	0	0		0	0	0		0	0	0		0	0	0		
Total %																	

Start Time	Coyote Canyon Road Southbound				Duncan Canyon Road Westbound				Coyote Canyon Road Northbound				Duncan Canyon Road Eastbound				Int. Total
	Left	Thru	Right	App. Total	Left	Thru	Right	App. Total	Left	Thru	Right	App. Total	Left	Thru	Right	App. Total	
Peak Hour Analysis From 07:15 AM to 08:00 AM - Peak 1 of 1																	
Peak Hour for Entire Intersection Begins at 07:15 AM																	
07:15 AM	0	0	0	0	0	0	0	0	0	0	0	0	0	0	0	0	0
07:30 AM	0	0	0	0	0	0	0	0	0	0	0	0	0	0	0	0	0
07:45 AM	0	0	0	0	0	0	0	0	0	0	0	0	0	0	0	0	0
08:00 AM	0	0	0	0	0	0	0	0	0	0	0	0	0	0	0	0	0
Total Volume	0	0	0	0	0	0	0	0	0	0	0	0	0	0	0	0	0
% App. Total	0	0	0		0	0	0		0	0	0		0	0	0		
PHF	.000	.000	.000	.000	.000	.000	.000	.000	.000	.000	.000	.000	.000	.000	.000	.000	.000

County of San Bernardino
 N/S: Coyote Canyon Road
 E/W: Duncan Canyon Road
 Weather: Clear

File Name : 01_CSB_Coyote Cyn_Duncan Cyn AM
 Site Code : 12218022
 Start Date : 1/24/2018
 Page No : 2

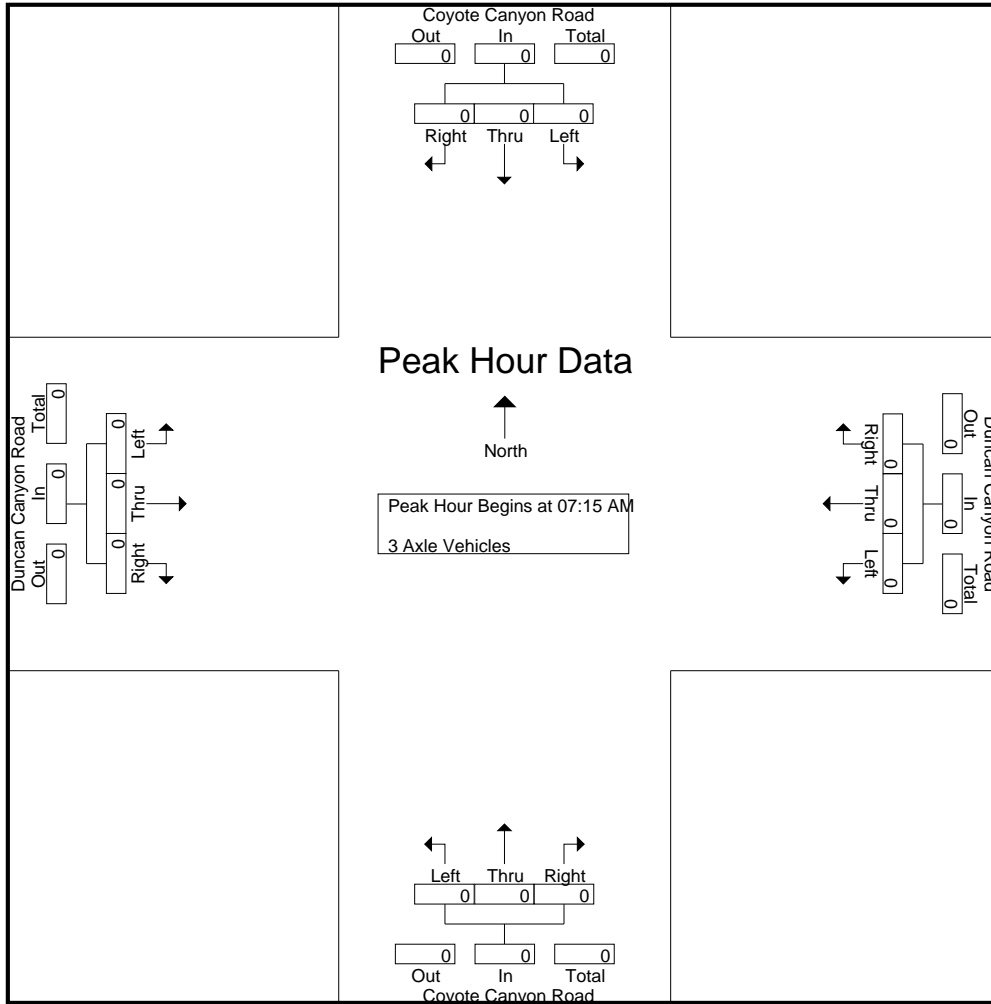

Peak Hour Analysis From 07:15 AM to 08:00 AM - Peak 1 of 1
 Peak Hour for Each Approach Begins at:

	07:15 AM				07:15 AM				07:15 AM				07:15 AM			
+0 mins.	0	0	0	0	0	0	0	0	0	0	0	0	0	0	0	0
+15 mins.	0	0	0	0	0	0	0	0	0	0	0	0	0	0	0	0
+30 mins.	0	0	0	0	0	0	0	0	0	0	0	0	0	0	0	0
+45 mins.	0	0	0	0	0	0	0	0	0	0	0	0	0	0	0	0
Total Volume	0	0	0	0	0	0	0	0	0	0	0	0	0	0	0	0
% App. Total	0	0	0	0	0	0	0	0	0	0	0	0	0	0	0	0
PHF	.000	.000	.000	.000	.000	.000	.000	.000	.000	.000	.000	.000	.000	.000	.000	.000

County of San Bernardino
 N/S: Coyote Canyon Road
 E/W: Duncan Canyon Road
 Weather: Clear

File Name : 01_CSB_Coyote Cyn_Duncan Cyn AM
 Site Code : 12218022
 Start Date : 1/24/2018
 Page No : 1

Groups Printed- 4+ Axle Trucks

Start Time	Coyote Canyon Road Southbound				Duncan Canyon Road Westbound				Coyote Canyon Road Northbound				Duncan Canyon Road Eastbound				Int. Total
	Left	Thru	Right	App. Total	Left	Thru	Right	App. Total	Left	Thru	Right	App. Total	Left	Thru	Right	App. Total	
07:00 AM	0	0	0	0	0	0	0	0	0	0	0	0	0	0	0	0	0
07:15 AM	0	0	0	0	0	0	0	0	0	0	0	0	0	0	0	0	0
07:30 AM	0	0	0	0	0	0	0	0	0	0	0	0	0	0	0	0	0
07:45 AM	0	0	0	0	0	0	0	0	0	0	0	0	0	0	0	0	0
Total	0	0	0	0	0	0	0	0	0	0	0	0	0	0	0	0	0
08:00 AM	0	0	0	0	0	0	0	0	0	0	0	0	0	0	0	0	0
08:15 AM	0	0	0	0	0	0	0	0	0	0	0	0	0	0	0	0	0
08:30 AM	0	0	0	0	0	0	0	0	0	0	0	0	0	0	0	0	0
08:45 AM	0	0	0	0	0	0	0	0	0	0	0	0	0	0	0	0	0
Total	0	0	0	0	0	0	0	0	0	0	0	0	0	0	0	0	0
Grand Total	0	0	0	0	0	0	0	0	0	0	0	0	0	0	0	0	0
Apprch %	0	0	0		0	0	0		0	0	0		0	0	0		
Total %																	

Start Time	Coyote Canyon Road Southbound				Duncan Canyon Road Westbound				Coyote Canyon Road Northbound				Duncan Canyon Road Eastbound				Int. Total
	Left	Thru	Right	App. Total	Left	Thru	Right	App. Total	Left	Thru	Right	App. Total	Left	Thru	Right	App. Total	
Peak Hour Analysis From 07:15 AM to 08:00 AM - Peak 1 of 1																	
Peak Hour for Entire Intersection Begins at 07:15 AM																	
07:15 AM	0	0	0	0	0	0	0	0	0	0	0	0	0	0	0	0	0
07:30 AM	0	0	0	0	0	0	0	0	0	0	0	0	0	0	0	0	0
07:45 AM	0	0	0	0	0	0	0	0	0	0	0	0	0	0	0	0	0
08:00 AM	0	0	0	0	0	0	0	0	0	0	0	0	0	0	0	0	0
Total Volume	0	0	0	0	0	0	0	0	0	0	0	0	0	0	0	0	0
% App. Total	0	0	0		0	0	0		0	0	0		0	0	0		
PHF	.000	.000	.000	.000	.000	.000	.000	.000	.000	.000	.000	.000	.000	.000	.000	.000	.000

County of San Bernardino
 N/S: Coyote Canyon Road
 E/W: Duncan Canyon Road
 Weather: Clear

File Name : 01_CSB_Coyote Cyn_Duncan Cyn AM
 Site Code : 12218022
 Start Date : 1/24/2018
 Page No : 2

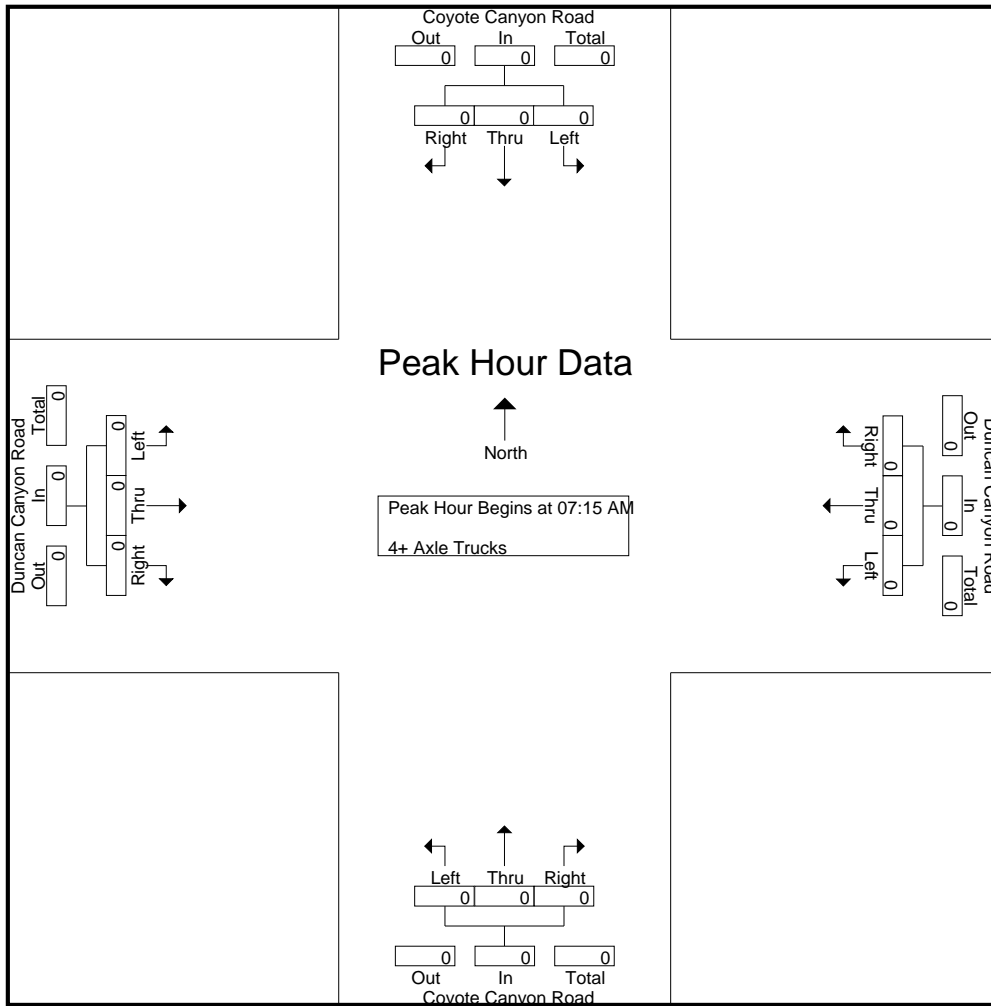

Peak Hour Analysis From 07:15 AM to 08:00 AM - Peak 1 of 1
 Peak Hour for Each Approach Begins at:

	07:15 AM				07:15 AM				07:15 AM				07:15 AM			
+0 mins.	0	0	0	0	0	0	0	0	0	0	0	0	0	0	0	0
+15 mins.	0	0	0	0	0	0	0	0	0	0	0	0	0	0	0	0
+30 mins.	0	0	0	0	0	0	0	0	0	0	0	0	0	0	0	0
+45 mins.	0	0	0	0	0	0	0	0	0	0	0	0	0	0	0	0
Total Volume	0	0	0	0	0	0	0	0	0	0	0	0	0	0	0	0
% App. Total	0	0	0	0	0	0	0	0	0	0	0	0	0	0	0	0
PHF	.000	.000	.000	.000	.000	.000	.000	.000	.000	.000	.000	.000	.000	.000	.000	.000

County of San Bernardino
 N/S: Coyote Canyon Road
 E/W: Duncan Canyon Road
 Weather: Clear

File Name : 01_CSB_Coyote Cyn_Duncan Cyn PM
 Site Code : 12218022
 Start Date : 1/24/2018
 Page No : 1

Groups Printed- Passenger Vehicles - Large 2 Axle Vehicles - 3 Axle Vehicles - 4+ Axle Trucks

Start Time	Coyote Canyon Road Southbound				Duncan Canyon Road Westbound				Coyote Canyon Road Northbound				Duncan Canyon Road Eastbound				Int. Total
	Left	Thru	Right	App. Total	Left	Thru	Right	App. Total	Left	Thru	Right	App. Total	Left	Thru	Right	App. Total	
04:00 PM	4	2	1	7	18	53	3	74	0	0	12	12	0	30	3	33	126
04:15 PM	1	0	1	2	18	65	7	90	1	2	17	20	3	39	1	43	155
04:30 PM	5	0	1	6	19	42	4	65	3	1	23	27	4	43	3	50	148
04:45 PM	10	0	0	10	24	56	6	86	0	0	13	13	3	33	0	36	145
Total	20	2	3	25	79	216	20	315	4	3	65	72	10	145	7	162	574
05:00 PM	6	0	0	6	26	55	12	93	2	0	17	19	2	32	3	37	155
05:15 PM	2	0	0	2	39	65	12	116	2	1	18	21	2	42	6	50	189
05:30 PM	7	0	1	8	26	45	8	79	3	0	22	25	4	40	3	47	159
05:45 PM	5	0	2	7	25	60	9	94	2	0	15	17	2	36	2	40	158
Total	20	0	3	23	116	225	41	382	9	1	72	82	10	150	14	174	661
Grand Total	40	2	6	48	195	441	61	697	13	4	137	154	20	295	21	336	1235
Apprch %	83.3	4.2	12.5		28	63.3	8.8		8.4	2.6	89		6	87.8	6.2		
Total %	3.2	0.2	0.5	3.9	15.8	35.7	4.9	56.4	1.1	0.3	11.1	12.5	1.6	23.9	1.7	27.2	
Passenger Vehicles	40	2	6	48	194	438	61	693	13	4	137	154	19	293	21	333	1228
% Passenger Vehicles	100	100	100	100	99.5	99.3	100	99.4	100	100	100	100	95	99.3	100	99.1	99.4
Large 2 Axle Vehicles	0	0	0	0	1	2	0	3	0	0	0	0	1	2	0	3	6
% Large 2 Axle Vehicles	0	0	0	0	0.5	0.5	0	0.4	0	0	0	0	5	0.7	0	0.9	0.5
3 Axle Vehicles	0	0	0	0	0	1	0	1	0	0	0	0	0	0	0	0	1
% 3 Axle Vehicles	0	0	0	0	0	0.2	0	0.1	0	0	0	0	0	0	0	0	0.1
4+ Axle Trucks	0	0	0	0	0	0	0	0	0	0	0	0	0	0	0	0	0
% 4+ Axle Trucks	0	0	0	0	0	0	0	0	0	0	0	0	0	0	0	0	0

Start Time	Coyote Canyon Road Southbound				Duncan Canyon Road Westbound				Coyote Canyon Road Northbound				Duncan Canyon Road Eastbound				Int. Total
	Left	Thru	Right	App. Total	Left	Thru	Right	App. Total	Left	Thru	Right	App. Total	Left	Thru	Right	App. Total	
Peak Hour Analysis From 04:00 PM to 05:45 PM - Peak 1 of 1																	
Peak Hour for Entire Intersection Begins at 05:00 PM																	
05:00 PM	6	0	0	6	26	55	12	93	2	0	17	19	2	32	3	37	155
05:15 PM	2	0	0	2	39	65	12	116	2	1	18	21	2	42	6	50	189
05:30 PM	7	0	1	8	26	45	8	79	3	0	22	25	4	40	3	47	159
05:45 PM	5	0	2	7	25	60	9	94	2	0	15	17	2	36	2	40	158
Total Volume	20	0	3	23	116	225	41	382	9	1	72	82	10	150	14	174	661
% App. Total	87	0	13		30.4	58.9	10.7		11	1.2	87.8		5.7	86.2	8		
PHF	.714	.000	.375	.719	.744	.865	.854	.823	.750	.250	.818	.820	.625	.893	.583	.870	.874

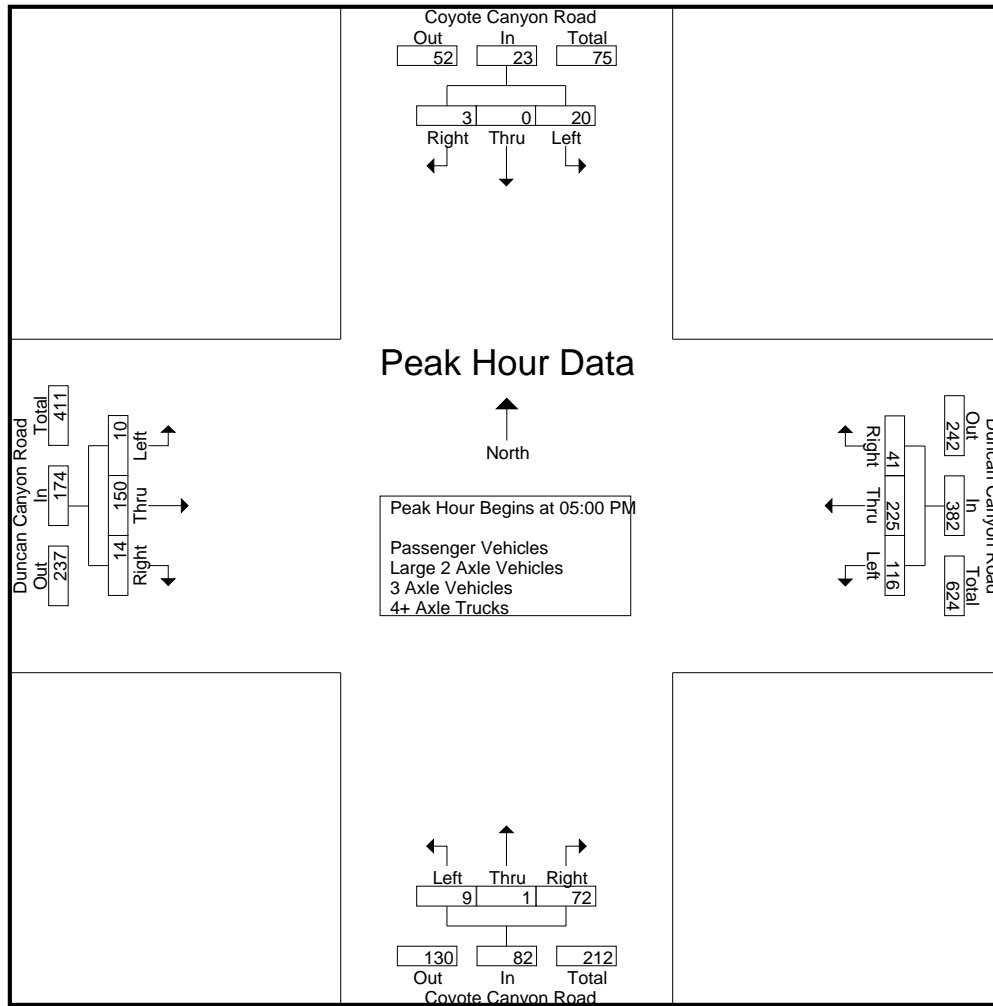

Peak Hour Analysis From 04:00 PM to 05:45 PM - Peak 1 of 1
 Peak Hour for Each Approach Begins at:

	04:45 PM				05:00 PM				05:00 PM				05:00 PM			
+0 mins.	10	0	0	10	26	55	12	93	2	0	17	19	2	32	3	37
+15 mins.	6	0	0	6	39	65	12	116	2	1	18	21	2	42	6	50
+30 mins.	2	0	0	2	26	45	8	79	3	0	22	25	4	40	3	47
+45 mins.	7	0	1	8	25	60	9	94	2	0	15	17	2	36	2	40
Total Volume	25	0	1	26	116	225	41	382	9	1	72	82	10	150	14	174
% App. Total	96.2	0	3.8		30.4	58.9	10.7		11	1.2	87.8		5.7	86.2	8	
PHF	.625	.000	.250	.650	.744	.865	.854	.823	.750	.250	.818	.820	.625	.893	.583	.870

County of San Bernardino
 N/S: Coyote Canyon Road
 E/W: Duncan Canyon Road
 Weather: Clear

File Name : 01_CSB_Coyote Cyn_Duncan Cyn PM
 Site Code : 12218022
 Start Date : 1/24/2018
 Page No : 1

Groups Printed- Passenger Vehicles

Start Time	Coyote Canyon Road Southbound				Duncan Canyon Road Westbound				Coyote Canyon Road Northbound				Duncan Canyon Road Eastbound				Int. Total
	Left	Thru	Right	App. Total	Left	Thru	Right	App. Total	Left	Thru	Right	App. Total	Left	Thru	Right	App. Total	
04:00 PM	4	2	1	7	18	53	3	74	0	0	12	12	0	30	3	33	126
04:15 PM	1	0	1	2	18	63	7	88	1	2	17	20	3	39	1	43	153
04:30 PM	5	0	1	6	19	42	4	65	3	1	23	27	3	42	3	48	146
04:45 PM	10	0	0	10	24	56	6	86	0	0	13	13	3	32	0	35	144
Total	20	2	3	25	79	214	20	313	4	3	65	72	9	143	7	159	569
05:00 PM	6	0	0	6	26	55	12	93	2	0	17	19	2	32	3	37	155
05:15 PM	2	0	0	2	39	64	12	115	2	1	18	21	2	42	6	50	188
05:30 PM	7	0	1	8	26	45	8	79	3	0	22	25	4	40	3	47	159
05:45 PM	5	0	2	7	24	60	9	93	2	0	15	17	2	36	2	40	157
Total	20	0	3	23	115	224	41	380	9	1	72	82	10	150	14	174	659
Grand Total	40	2	6	48	194	438	61	693	13	4	137	154	19	293	21	333	1228
Apprch %	83.3	4.2	12.5		28	63.2	8.8		8.4	2.6	89		5.7	88	6.3		
Total %	3.3	0.2	0.5	3.9	15.8	35.7	5	56.4	1.1	0.3	11.2	12.5	1.5	23.9	1.7	27.1	

Start Time	Coyote Canyon Road Southbound				Duncan Canyon Road Westbound				Coyote Canyon Road Northbound				Duncan Canyon Road Eastbound				Int. Total
	Left	Thru	Right	App. Total	Left	Thru	Right	App. Total	Left	Thru	Right	App. Total	Left	Thru	Right	App. Total	
Peak Hour Analysis From 05:00 PM to 05:45 PM - Peak 1 of 1																	
Peak Hour for Entire Intersection Begins at 05:00 PM																	
05:00 PM	6	0	0	6	26	55	12	93	2	0	17	19	2	32	3	37	155
05:15 PM	2	0	0	2	39	64	12	115	2	1	18	21	2	42	6	50	188
05:30 PM	7	0	1	8	26	45	8	79	3	0	22	25	4	40	3	47	159
05:45 PM	5	0	2	7	24	60	9	93	2	0	15	17	2	36	2	40	157
Total Volume	20	0	3	23	115	224	41	380	9	1	72	82	10	150	14	174	659
% App. Total	87	0	13		30.3	58.9	10.8		11	1.2	87.8		5.7	86.2	8		
PHF	.714	.000	.375	.719	.737	.875	.854	.826	.750	.250	.818	.820	.625	.893	.583	.870	.876

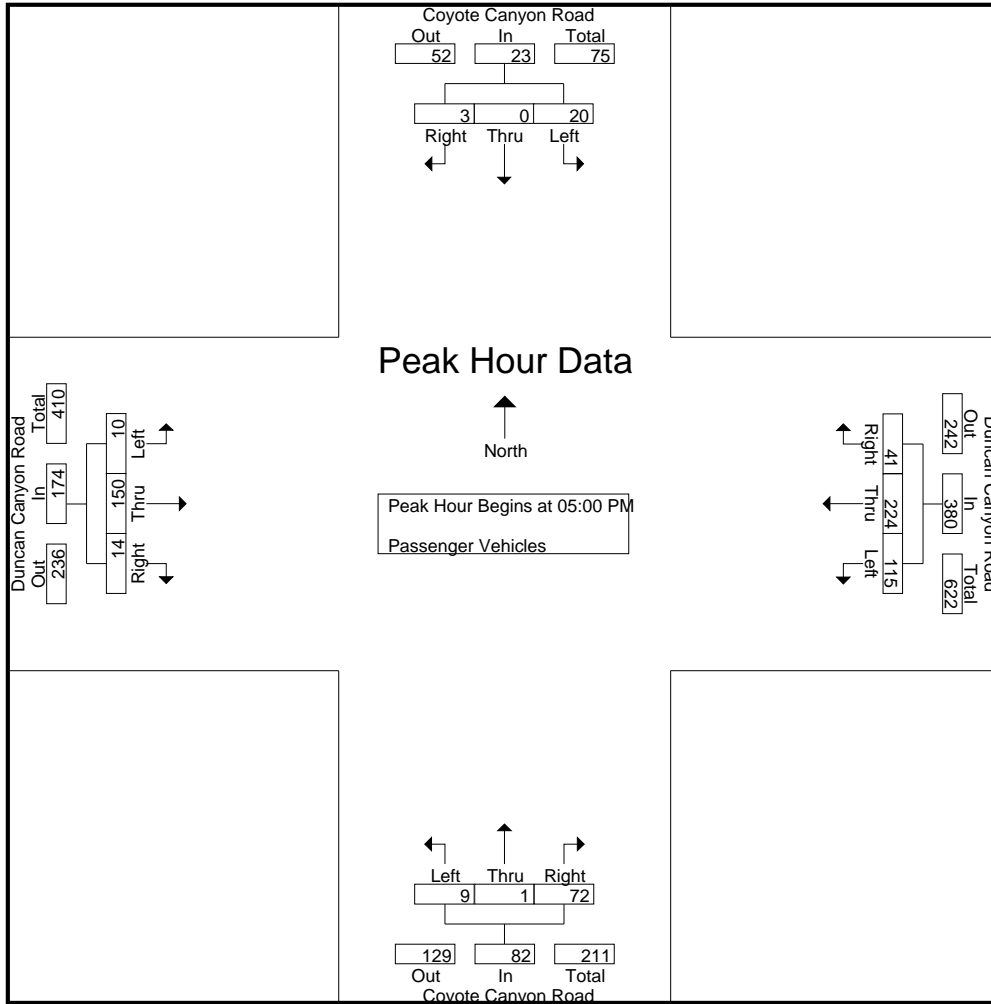

Peak Hour Analysis From 05:00 PM to 05:45 PM - Peak 1 of 1
 Peak Hour for Each Approach Begins at:

	05:00 PM				05:00 PM				05:00 PM				05:00 PM			
+0 mins.	6	0	0	6	26	55	12	93	2	0	17	19	2	32	3	37
+15 mins.	2	0	0	2	39	64	12	115	2	1	18	21	2	42	6	50
+30 mins.	7	0	1	8	26	45	8	79	3	0	22	25	4	40	3	47
+45 mins.	5	0	2	7	24	60	9	93	2	0	15	17	2	36	2	40
Total Volume	20	0	3	23	115	224	41	380	9	1	72	82	10	150	14	174
% App. Total	87	0	13		30.3	58.9	10.8		11	1.2	87.8		5.7	86.2	8	
PHF	.714	.000	.375	.719	.737	.875	.854	.826	.750	.250	.818	.820	.625	.893	.583	.870

County of San Bernardino
 N/S: Coyote Canyon Road
 E/W: Duncan Canyon Road
 Weather: Clear

File Name : 01_CSB_Coyote Cyn_Duncan Cyn PM
 Site Code : 12218022
 Start Date : 1/24/2018
 Page No : 1

Groups Printed- Large 2 Axle Vehicles

Start Time	Coyote Canyon Road Southbound				Duncan Canyon Road Westbound				Coyote Canyon Road Northbound				Duncan Canyon Road Eastbound				Int. Total
	Left	Thru	Right	App. Total	Left	Thru	Right	App. Total	Left	Thru	Right	App. Total	Left	Thru	Right	App. Total	
04:00 PM	0	0	0	0	0	0	0	0	0	0	0	0	0	0	0	0	0
04:15 PM	0	0	0	0	0	2	0	2	0	0	0	0	0	0	0	0	0
04:30 PM	0	0	0	0	0	0	0	0	0	0	0	0	1	1	0	2	2
04:45 PM	0	0	0	0	0	0	0	0	0	0	0	0	0	1	0	1	1
Total	0	0	0	0	0	2	0	2	0	0	0	0	1	2	0	3	5
05:00 PM	0	0	0	0	0	0	0	0	0	0	0	0	0	0	0	0	0
05:15 PM	0	0	0	0	0	0	0	0	0	0	0	0	0	0	0	0	0
05:30 PM	0	0	0	0	0	0	0	0	0	0	0	0	0	0	0	0	0
05:45 PM	0	0	0	0	1	0	0	1	0	0	0	0	0	0	0	0	1
Total	0	0	0	0	1	0	0	1	0	0	0	0	0	0	0	0	1
Grand Total	0	0	0	0	1	2	0	3	0	0	0	0	1	2	0	3	6
Apprch %	0	0	0		33.3	66.7	0		0	0	0		33.3	66.7	0		
Total %	0	0	0		16.7	33.3	0	50	0	0	0		16.7	33.3	0	50	

Start Time	Coyote Canyon Road Southbound				Duncan Canyon Road Westbound				Coyote Canyon Road Northbound				Duncan Canyon Road Eastbound				Int. Total
	Left	Thru	Right	App. Total	Left	Thru	Right	App. Total	Left	Thru	Right	App. Total	Left	Thru	Right	App. Total	
Peak Hour Analysis From 05:00 PM to 05:45 PM - Peak 1 of 1																	
Peak Hour for Entire Intersection Begins at 05:00 PM																	
05:00 PM	0	0	0	0	0	0	0	0	0	0	0	0	0	0	0	0	0
05:15 PM	0	0	0	0	0	0	0	0	0	0	0	0	0	0	0	0	0
05:30 PM	0	0	0	0	0	0	0	0	0	0	0	0	0	0	0	0	0
05:45 PM	0	0	0	0	1	0	0	1	0	0	0	0	0	0	0	0	1
Total Volume	0	0	0	0	1	0	0	1	0	0	0	0	0	0	0	0	1
% App. Total	0	0	0		100	0	0		0	0	0		0	0	0		
PHF	.000	.000	.000	.000	.250	.000	.000	.250	.000	.000	.000	.000	.000	.000	.000	.000	.250

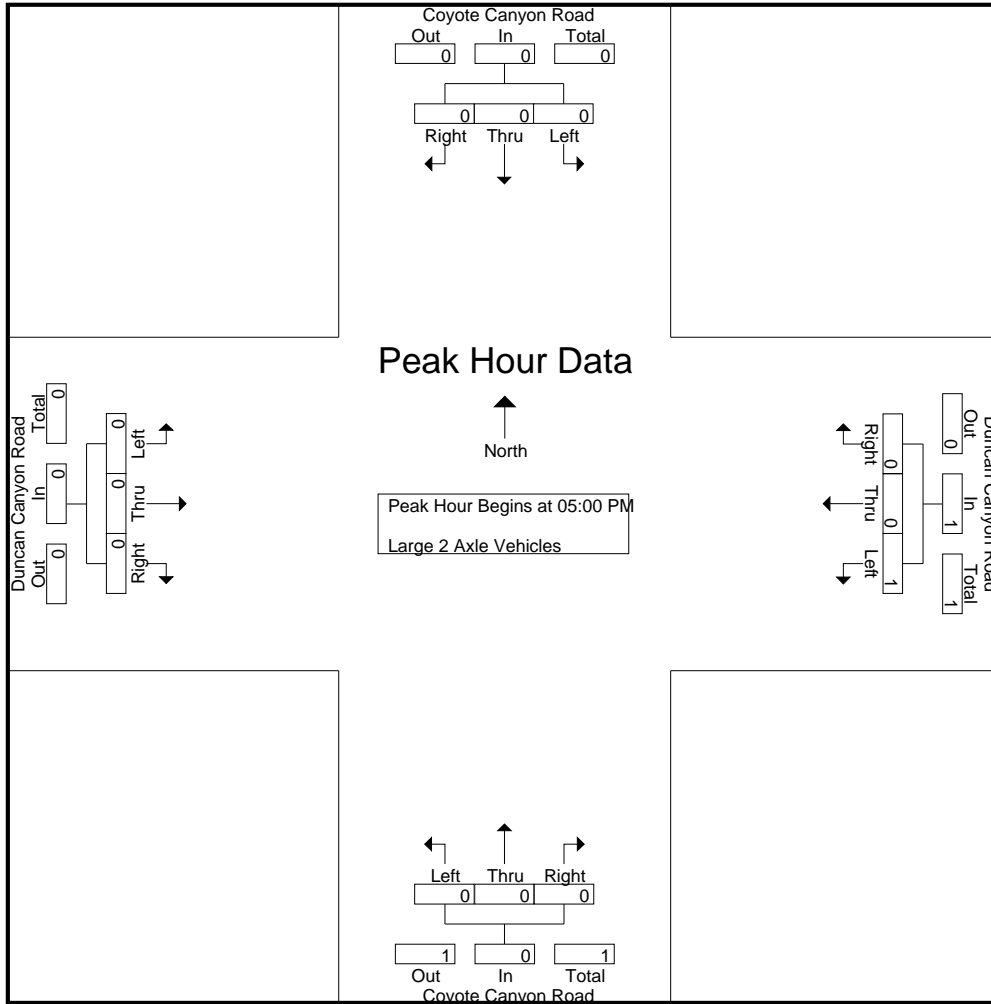

Peak Hour Analysis From 05:00 PM to 05:45 PM - Peak 1 of 1
 Peak Hour for Each Approach Begins at:

	05:00 PM				05:00 PM				05:00 PM				05:00 PM			
+0 mins.	0	0	0	0	0	0	0	0	0	0	0	0	0	0	0	0
+15 mins.	0	0	0	0	0	0	0	0	0	0	0	0	0	0	0	0
+30 mins.	0	0	0	0	0	0	0	0	0	0	0	0	0	0	0	0
+45 mins.	0	0	0	0	1	0	0	1	0	0	0	0	0	0	0	0
Total Volume	0	0	0	0	1	0	0	1	0	0	0	0	0	0	0	0
% App. Total	0	0	0	0	100	0	0	0	0	0	0	0	0	0	0	0
PHF	.000	.000	.000	.000	.250	.000	.000	.250	.000	.000	.000	.000	.000	.000	.000	.000

County of San Bernardino
 N/S: Coyote Canyon Road
 E/W: Duncan Canyon Road
 Weather: Clear

File Name : 01_CSB_Coyote Cyn_Duncan Cyn PM
 Site Code : 12218022
 Start Date : 1/24/2018
 Page No : 1

Groups Printed- 3 Axle Vehicles

Start Time	Coyote Canyon Road Southbound				Duncan Canyon Road Westbound				Coyote Canyon Road Northbound				Duncan Canyon Road Eastbound				Int. Total
	Left	Thru	Right	App. Total	Left	Thru	Right	App. Total	Left	Thru	Right	App. Total	Left	Thru	Right	App. Total	
04:00 PM	0	0	0	0	0	0	0	0	0	0	0	0	0	0	0	0	0
04:15 PM	0	0	0	0	0	0	0	0	0	0	0	0	0	0	0	0	0
04:30 PM	0	0	0	0	0	0	0	0	0	0	0	0	0	0	0	0	0
04:45 PM	0	0	0	0	0	0	0	0	0	0	0	0	0	0	0	0	0
Total	0	0	0	0	0	0	0	0	0	0	0	0	0	0	0	0	0
05:00 PM	0	0	0	0	0	0	0	0	0	0	0	0	0	0	0	0	0
05:15 PM	0	0	0	0	0	1	0	1	0	0	0	0	0	0	0	0	1
05:30 PM	0	0	0	0	0	0	0	0	0	0	0	0	0	0	0	0	0
05:45 PM	0	0	0	0	0	0	0	0	0	0	0	0	0	0	0	0	0
Total	0	0	0	0	0	1	0	1	0	0	0	0	0	0	0	0	1
Grand Total	0	0	0	0	0	1	0	1	0	0	0	0	0	0	0	0	1
Apprch %	0	0	0		0	100	0		0	0	0		0	0	0		
Total %	0	0	0		0	100	0	100	0	0	0		0	0	0		

Start Time	Coyote Canyon Road Southbound				Duncan Canyon Road Westbound				Coyote Canyon Road Northbound				Duncan Canyon Road Eastbound				Int. Total
	Left	Thru	Right	App. Total	Left	Thru	Right	App. Total	Left	Thru	Right	App. Total	Left	Thru	Right	App. Total	
Peak Hour Analysis From 05:00 PM to 05:45 PM - Peak 1 of 1																	
Peak Hour for Entire Intersection Begins at 05:00 PM																	
05:00 PM	0	0	0	0	0	0	0	0	0	0	0	0	0	0	0	0	0
05:15 PM	0	0	0	0	0	1	0	1	0	0	0	0	0	0	0	0	1
05:30 PM	0	0	0	0	0	0	0	0	0	0	0	0	0	0	0	0	0
05:45 PM	0	0	0	0	0	0	0	0	0	0	0	0	0	0	0	0	0
Total Volume	0	0	0	0	0	1	0	1	0	0	0	0	0	0	0	0	1
% App. Total	0	0	0		0	100	0		0	0	0		0	0	0		
PHF	.000	.000	.000	.000	.000	.250	.000	.250	.000	.000	.000	.000	.000	.000	.000	.000	.250

County of San Bernardino
 N/S: Coyote Canyon Road
 E/W: Duncan Canyon Road
 Weather: Clear

File Name : 01_CSB_Coyote Cyn_Duncan Cyn PM
 Site Code : 12218022
 Start Date : 1/24/2018
 Page No : 2

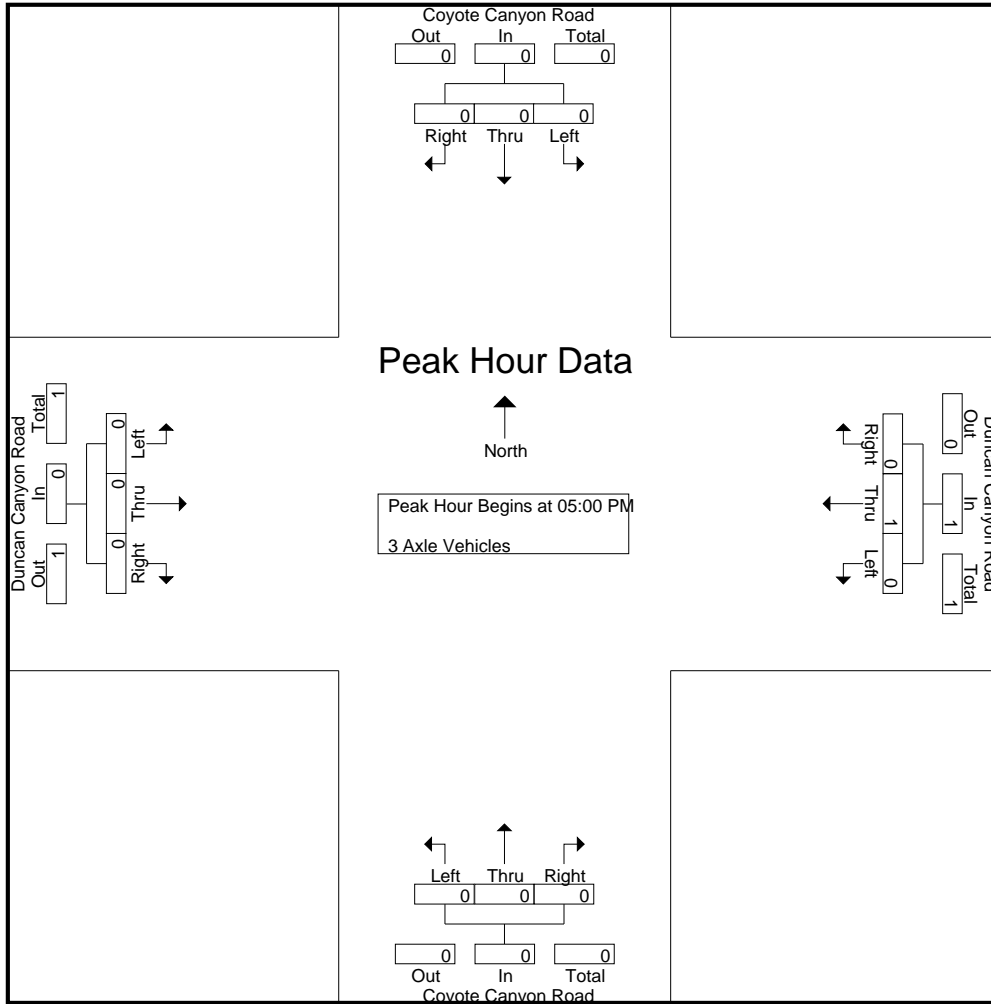

Peak Hour Analysis From 05:00 PM to 05:45 PM - Peak 1 of 1
 Peak Hour for Each Approach Begins at:

	05:00 PM				05:00 PM				05:00 PM				05:00 PM			
+0 mins.	0	0	0	0	0	0	0	0	0	0	0	0	0	0	0	0
+15 mins.	0	0	0	0	0	1	0	1	0	0	0	0	0	0	0	0
+30 mins.	0	0	0	0	0	0	0	0	0	0	0	0	0	0	0	0
+45 mins.	0	0	0	0	0	0	0	0	0	0	0	0	0	0	0	0
Total Volume	0	0	0	0	0	1	0	1	0	0	0	0	0	0	0	0
% App. Total	0	0	0	0	0	100	0	0	0	0	0	0	0	0	0	0
PHF	.000	.000	.000	.000	.000	.250	.000	.250	.000	.000	.000	.000	.000	.000	.000	.000

County of San Bernardino
 N/S: Coyote Canyon Road
 E/W: Duncan Canyon Road
 Weather: Clear

File Name : 01_CSB_Coyote Cyn_Duncan Cyn PM
 Site Code : 12218022
 Start Date : 1/24/2018
 Page No : 1

Groups Printed- 4+ Axle Trucks

Start Time	Coyote Canyon Road Southbound				Duncan Canyon Road Westbound				Coyote Canyon Road Northbound				Duncan Canyon Road Eastbound				Int. Total
	Left	Thru	Right	App. Total	Left	Thru	Right	App. Total	Left	Thru	Right	App. Total	Left	Thru	Right	App. Total	
04:00 PM	0	0	0	0	0	0	0	0	0	0	0	0	0	0	0	0	0
04:15 PM	0	0	0	0	0	0	0	0	0	0	0	0	0	0	0	0	0
04:30 PM	0	0	0	0	0	0	0	0	0	0	0	0	0	0	0	0	0
04:45 PM	0	0	0	0	0	0	0	0	0	0	0	0	0	0	0	0	0
Total	0	0	0	0	0	0	0	0	0	0	0	0	0	0	0	0	0
05:00 PM	0	0	0	0	0	0	0	0	0	0	0	0	0	0	0	0	0
05:15 PM	0	0	0	0	0	0	0	0	0	0	0	0	0	0	0	0	0
05:30 PM	0	0	0	0	0	0	0	0	0	0	0	0	0	0	0	0	0
05:45 PM	0	0	0	0	0	0	0	0	0	0	0	0	0	0	0	0	0
Total	0	0	0	0	0	0	0	0	0	0	0	0	0	0	0	0	0
Grand Total	0	0	0	0	0	0	0	0	0	0	0	0	0	0	0	0	0
Apprch %	0	0	0		0	0	0		0	0	0		0	0	0		
Total %																	

Start Time	Coyote Canyon Road Southbound				Duncan Canyon Road Westbound				Coyote Canyon Road Northbound				Duncan Canyon Road Eastbound				Int. Total
	Left	Thru	Right	App. Total	Left	Thru	Right	App. Total	Left	Thru	Right	App. Total	Left	Thru	Right	App. Total	
Peak Hour Analysis From 05:00 PM to 05:45 PM - Peak 1 of 1																	
Peak Hour for Entire Intersection Begins at 05:00 PM																	
05:00 PM	0	0	0	0	0	0	0	0	0	0	0	0	0	0	0	0	0
05:15 PM	0	0	0	0	0	0	0	0	0	0	0	0	0	0	0	0	0
05:30 PM	0	0	0	0	0	0	0	0	0	0	0	0	0	0	0	0	0
05:45 PM	0	0	0	0	0	0	0	0	0	0	0	0	0	0	0	0	0
Total Volume	0	0	0	0	0	0	0	0	0	0	0	0	0	0	0	0	0
% App. Total	0	0	0		0	0	0		0	0	0		0	0	0		
PHF	.000	.000	.000	.000	.000	.000	.000	.000	.000	.000	.000	.000	.000	.000	.000	.000	.000

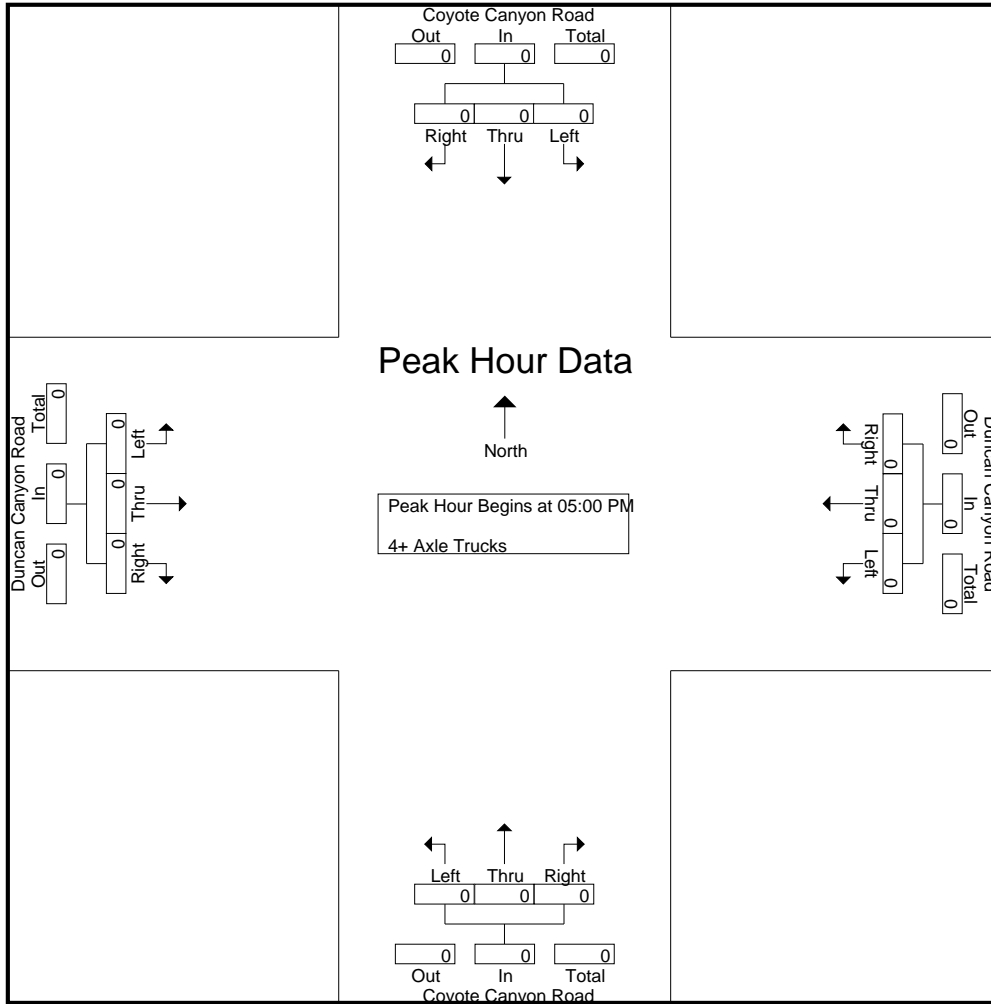

Peak Hour Analysis From 05:00 PM to 05:45 PM - Peak 1 of 1
 Peak Hour for Each Approach Begins at:

	05:00 PM				05:00 PM				05:00 PM				05:00 PM			
+0 mins.	0	0	0	0	0	0	0	0	0	0	0	0	0	0	0	0
+15 mins.	0	0	0	0	0	0	0	0	0	0	0	0	0	0	0	0
+30 mins.	0	0	0	0	0	0	0	0	0	0	0	0	0	0	0	0
+45 mins.	0	0	0	0	0	0	0	0	0	0	0	0	0	0	0	0
Total Volume	0	0	0	0	0	0	0	0	0	0	0	0	0	0	0	0
% App. Total	0	0	0	0	0	0	0	0	0	0	0	0	0	0	0	0
PHF	.000	.000	.000	.000	.000	.000	.000	.000	.000	.000	.000	.000	.000	.000	.000	.000

County of San Bernardino
 N/S: Lytle Creek Road
 E/W: Duncan Canyon Road
 Weather: Clear

File Name : 02_CSB_Lytle Creek_Duncan Cyn AM
 Site Code : 12218022
 Start Date : 1/24/2018
 Page No : 1

Groups Printed- Passenger Vehicles - Large 2 Axle Vehicles - 3 Axle Vehicles - 4+ Axle Trucks

Start Time	Lytle Creek Road Southbound			Duncan Canyon Road Westbound			Duncan Canyon Road Eastbound			Int. Total
	Left	Right	App. Total	Thru	Right	App. Total	Left	Thru	App. Total	
07:00 AM	0	5	5	27	0	27	0	106	106	138
07:15 AM	0	6	6	22	0	22	0	118	118	146
07:30 AM	0	3	3	32	1	33	0	115	115	151
07:45 AM	0	1	1	35	1	36	0	94	94	131
Total	0	15	15	116	2	118	0	433	433	566
08:00 AM	0	0	0	34	1	35	0	95	95	130
08:15 AM	0	1	1	39	1	40	0	75	75	116
08:30 AM	0	1	1	38	0	38	0	56	56	95
08:45 AM	0	1	1	23	0	23	0	53	53	77
Total	0	3	3	134	2	136	0	279	279	418
Grand Total	0	18	18	250	4	254	0	712	712	984
Apprch %	0	100		98.4	1.6		0	100		
Total %	0	1.8	1.8	25.4	0.4	25.8	0	72.4	72.4	
Passenger Vehicles	0	18	18	246	2	248	0	708	708	974
% Passenger Vehicles	0	100	100	98.4	50	97.6	0	99.4	99.4	99
Large 2 Axle Vehicles	0	0	0	4	2	6	0	4	4	10
% Large 2 Axle Vehicles	0	0	0	1.6	50	2.4	0	0.6	0.6	1
3 Axle Vehicles	0	0	0	0	0	0	0	0	0	0
% 3 Axle Vehicles	0	0	0	0	0	0	0	0	0	0
4+ Axle Trucks	0	0	0	0	0	0	0	0	0	0
% 4+ Axle Trucks	0	0	0	0	0	0	0	0	0	0

Start Time	Lytle Creek Road Southbound			Duncan Canyon Road Westbound			Duncan Canyon Road Eastbound			Int. Total
	Left	Right	App. Total	Thru	Right	App. Total	Left	Thru	App. Total	
07:00 AM	0	5	5	27	0	27	0	106	106	138
07:15 AM	0	6	6	22	0	22	0	118	118	146
07:30 AM	0	3	3	32	1	33	0	115	115	151
07:45 AM	0	1	1	35	1	36	0	94	94	131
Total Volume	0	15	15	116	2	118	0	433	433	566
% App. Total	0	100		98.3	1.7		0	100		
PHF	.000	.625	.625	.829	.500	.819	.000	.917	.917	.937

Peak Hour Analysis From 07:00 AM to 08:45 AM - Peak 1 of 1
 Peak Hour for Entire Intersection Begins at 07:00 AM

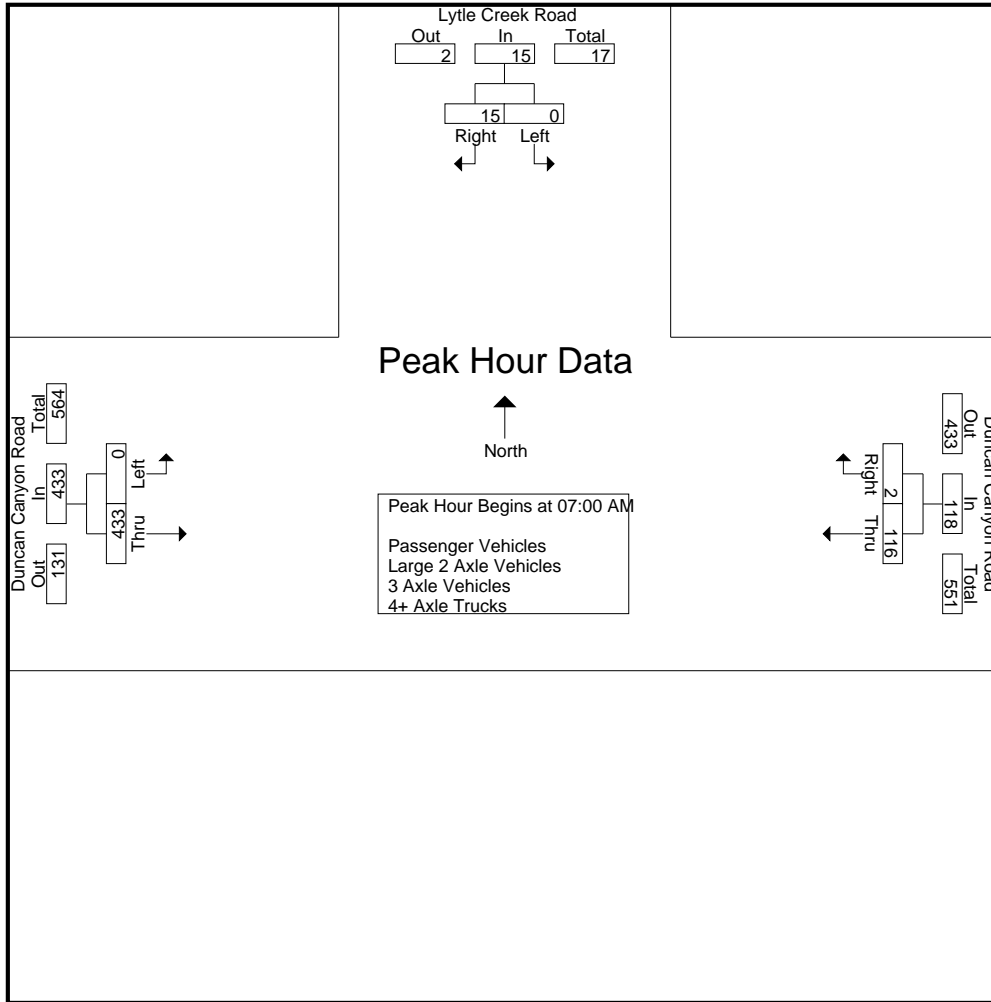

Peak Hour Analysis From 07:00 AM to 08:45 AM - Peak 1 of 1
 Peak Hour for Each Approach Begins at:

	07:00 AM			07:45 AM			07:00 AM		
+0 mins.	0	5	5	35	1	36	0	106	106
+15 mins.	0	6	6	34	1	35	0	118	118
+30 mins.	0	3	3	39	1	40	0	115	115
+45 mins.	0	1	1	38	0	38	0	94	94
Total Volume	0	15	15	146	3	149	0	433	433
% App. Total	0	100		98	2		0	100	
PHF	.000	.625	.625	.936	.750	.931	.000	.917	.917

County of San Bernardino
 N/S: Lytle Creek Road
 E/W: Duncan Canyon Road
 Weather: Clear

File Name : 02_CSB_Lytle Creek_Duncan Cyn AM
 Site Code : 12218022
 Start Date : 1/24/2018
 Page No : 1

Groups Printed- Passenger Vehicles

Start Time	Lytle Creek Road Southbound			Duncan Canyon Road Westbound			Duncan Canyon Road Eastbound			Int. Total
	Left	Right	App. Total	Thru	Right	App. Total	Left	Thru	App. Total	
07:00 AM	0	5	5	27	0	27	0	106	106	138
07:15 AM	0	6	6	22	0	22	0	117	117	145
07:30 AM	0	3	3	32	1	33	0	114	114	150
07:45 AM	0	1	1	32	0	32	0	94	94	127
Total	0	15	15	113	1	114	0	431	431	560
08:00 AM	0	0	0	34	1	35	0	94	94	129
08:15 AM	0	1	1	39	0	39	0	75	75	115
08:30 AM	0	1	1	37	0	37	0	56	56	94
08:45 AM	0	1	1	23	0	23	0	52	52	76
Total	0	3	3	133	1	134	0	277	277	414
Grand Total	0	18	18	246	2	248	0	708	708	974
Apprch %	0	100		99.2	0.8		0	100		
Total %	0	1.8	1.8	25.3	0.2	25.5	0	72.7	72.7	

Start Time	Lytle Creek Road Southbound			Duncan Canyon Road Westbound			Duncan Canyon Road Eastbound			Int. Total
	Left	Right	App. Total	Thru	Right	App. Total	Left	Thru	App. Total	
07:00 AM	0	5	5	27	0	27	0	106	106	138
07:15 AM	0	6	6	22	0	22	0	117	117	145
07:30 AM	0	3	3	32	1	33	0	114	114	150
07:45 AM	0	1	1	32	0	32	0	94	94	127
Total Volume	0	15	15	113	1	114	0	431	431	560
% App. Total	0	100		99.1	0.9		0	100		
PHF	.000	.625	.625	.883	.250	.864	.000	.921	.921	.933

Peak Hour Analysis From 07:00 AM to 07:45 AM - Peak 1 of 1
 Peak Hour for Entire Intersection Begins at 07:00 AM

County of San Bernardino
 N/S: Lytle Creek Road
 E/W: Duncan Canyon Road
 Weather: Clear

File Name : 02_CS_B_Lytle Creek_Duncan Cyn AM
 Site Code : 12218022
 Start Date : 1/24/2018
 Page No : 2

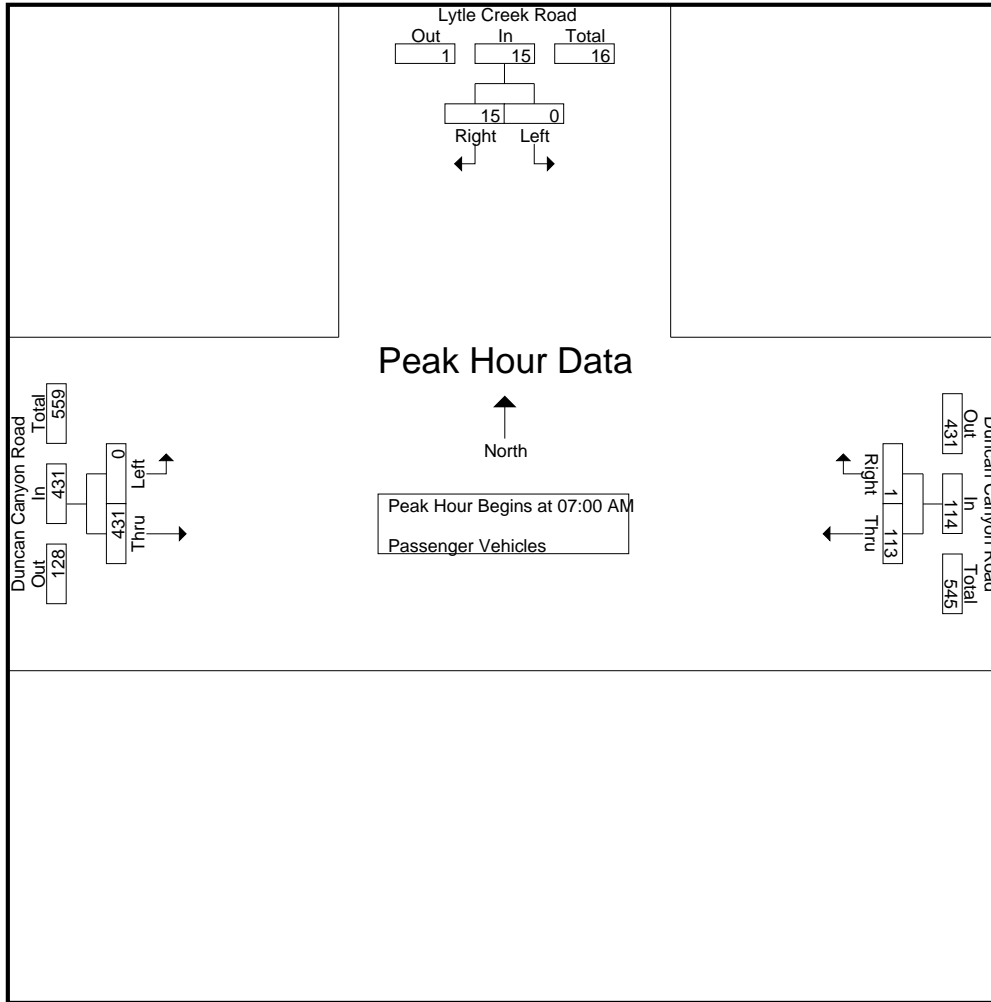

Peak Hour Analysis From 07:00 AM to 07:45 AM - Peak 1 of 1
 Peak Hour for Each Approach Begins at:

	07:00 AM			07:00 AM			07:00 AM		
+0 mins.	0	5	5	27	0	27	0	106	106
+15 mins.	0	6	6	22	0	22	0	117	117
+30 mins.	0	3	3	32	1	33	0	114	114
+45 mins.	0	1	1	32	0	32	0	94	94
Total Volume	0	15	15	113	1	114	0	431	431
% App. Total	0	100		99.1	0.9		0	100	
PHF	.000	.625	.625	.883	.250	.864	.000	.921	.921

County of San Bernardino
 N/S: Lytle Creek Road
 E/W: Duncan Canyon Road
 Weather: Clear

File Name : 02_CSB_Lytle Creek_Duncan Cyn AM
 Site Code : 12218022
 Start Date : 1/24/2018
 Page No : 1

Groups Printed- Large 2 Axle Vehicles

Start Time	Lytle Creek Road Southbound			Duncan Canyon Road Westbound			Duncan Canyon Road Eastbound			Int. Total
	Left	Right	App. Total	Thru	Right	App. Total	Left	Thru	App. Total	
07:00 AM	0	0	0	0	0	0	0	0	0	0
07:15 AM	0	0	0	0	0	0	0	1	1	1
07:30 AM	0	0	0	0	0	0	0	1	1	1
07:45 AM	0	0	0	3	1	4	0	0	0	4
Total	0	0	0	3	1	4	0	2	2	6
08:00 AM	0	0	0	0	0	0	0	1	1	1
08:15 AM	0	0	0	0	1	1	0	0	0	1
08:30 AM	0	0	0	1	0	1	0	0	0	1
08:45 AM	0	0	0	0	0	0	0	1	1	1
Total	0	0	0	1	1	2	0	2	2	4
Grand Total	0	0	0	4	2	6	0	4	4	10
Apprch %	0	0		66.7	33.3		0	100		
Total %	0	0		40	20	60	0	40	40	

Start Time	Lytle Creek Road Southbound			Duncan Canyon Road Westbound			Duncan Canyon Road Eastbound			Int. Total
	Left	Right	App. Total	Thru	Right	App. Total	Left	Thru	App. Total	
07:00 AM	0	0	0	0	0	0	0	0	0	0
07:15 AM	0	0	0	0	0	0	0	1	1	1
07:30 AM	0	0	0	0	0	0	0	1	1	1
07:45 AM	0	0	0	3	1	4	0	0	0	4
Total Volume	0	0	0	3	1	4	0	2	2	6
% App. Total	0	0		75	25		0	100		
PHF	.000	.000	.000	.250	.250	.250	.000	.500	.500	.375

Peak Hour Analysis From 07:00 AM to 07:45 AM - Peak 1 of 1

Peak Hour for Entire Intersection Begins at 07:00 AM

County of San Bernardino
 N/S: Lytle Creek Road
 E/W: Duncan Canyon Road
 Weather: Clear

File Name : 02_CSB_Lytle Creek_Duncan Cyn AM
 Site Code : 12218022
 Start Date : 1/24/2018
 Page No : 2

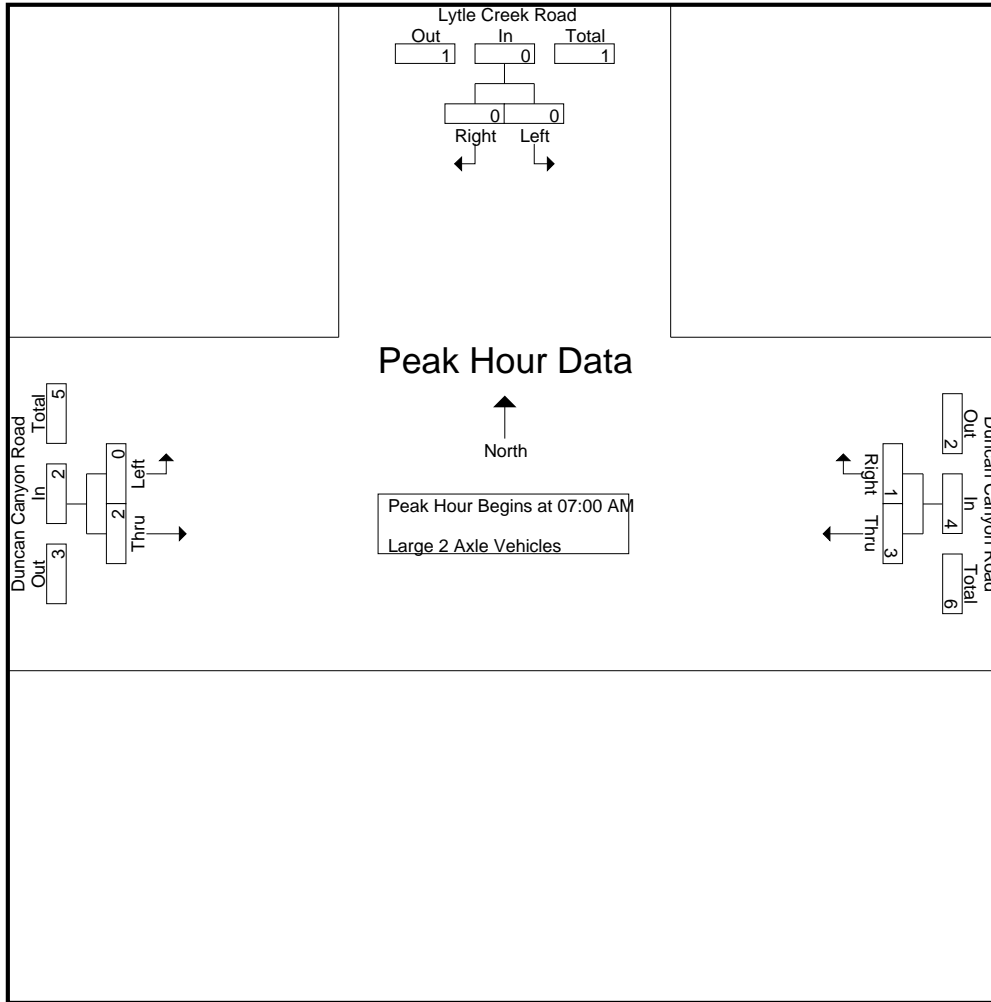

Peak Hour Analysis From 07:00 AM to 07:45 AM - Peak 1 of 1
 Peak Hour for Each Approach Begins at:

	07:00 AM			07:00 AM			07:00 AM		
+0 mins.	0	0	0	0	0	0	0	0	0
+15 mins.	0	0	0	0	0	0	0	1	1
+30 mins.	0	0	0	0	0	0	0	1	1
+45 mins.	0	0	0	3	1	4	0	0	0
Total Volume	0	0	0	3	1	4	0	2	2
% App. Total	0	0	0	75	25		0	100	
PHF	.000	.000	.000	.250	.250	.250	.000	.500	.500

County of San Bernardino
 N/S: Lytle Creek Road
 E/W: Duncan Canyon Road
 Weather: Clear

File Name : 02_CSB_Lytle Creek_Duncan Cyn AM
 Site Code : 12218022
 Start Date : 1/24/2018
 Page No : 1

Groups Printed- 3 Axle Vehicles

Start Time	Lytle Creek Road Southbound			Duncan Canyon Road Westbound			Duncan Canyon Road Eastbound			Int. Total
	Left	Right	App. Total	Thru	Right	App. Total	Left	Thru	App. Total	
07:00 AM	0	0	0	0	0	0	0	0	0	0
07:15 AM	0	0	0	0	0	0	0	0	0	0
07:30 AM	0	0	0	0	0	0	0	0	0	0
07:45 AM	0	0	0	0	0	0	0	0	0	0
Total	0	0	0	0	0	0	0	0	0	0
08:00 AM	0	0	0	0	0	0	0	0	0	0
08:15 AM	0	0	0	0	0	0	0	0	0	0
08:30 AM	0	0	0	0	0	0	0	0	0	0
08:45 AM	0	0	0	0	0	0	0	0	0	0
Total	0	0	0	0	0	0	0	0	0	0
Grand Total	0	0	0	0	0	0	0	0	0	0
Apprch %	0	0		0	0		0	0		
Total %										

Start Time	Lytle Creek Road Southbound			Duncan Canyon Road Westbound			Duncan Canyon Road Eastbound			Int. Total
	Left	Right	App. Total	Thru	Right	App. Total	Left	Thru	App. Total	
07:00 AM	0	0	0	0	0	0	0	0	0	0
07:15 AM	0	0	0	0	0	0	0	0	0	0
07:30 AM	0	0	0	0	0	0	0	0	0	0
07:45 AM	0	0	0	0	0	0	0	0	0	0
Total Volume	0	0	0	0	0	0	0	0	0	0
% App. Total	0	0		0	0		0	0		
PHF	.000	.000	.000	.000	.000	.000	.000	.000	.000	.000

Peak Hour Analysis From 07:00 AM to 07:45 AM - Peak 1 of 1

Peak Hour for Entire Intersection Begins at 07:00 AM

County of San Bernardino
 N/S: Lytle Creek Road
 E/W: Duncan Canyon Road
 Weather: Clear

File Name : 02_CSB_Lytle Creek_Duncan Cyn PM
 Site Code : 12218022
 Start Date : 1/24/2018
 Page No : 1

Groups Printed- Passenger Vehicles - Large 2 Axle Vehicles - 3 Axle Vehicles - 4+ Axle Trucks

Start Time	Lytle Creek Road Southbound			Duncan Canyon Road Westbound			Duncan Canyon Road Eastbound			Int. Total
	Left	Right	App. Total	Thru	Right	App. Total	Left	Thru	App. Total	
04:00 PM	0	3	3	75	3	78	0	49	49	130
04:15 PM	0	1	1	89	5	94	0	62	62	157
04:30 PM	0	1	1	69	1	70	0	67	67	138
04:45 PM	0	1	1	86	3	89	0	57	57	147
Total	0	6	6	319	12	331	0	235	235	572
05:00 PM	0	1	1	97	3	100	0	55	55	156
05:15 PM	0	0	0	109	6	115	0	65	65	180
05:30 PM	0	2	2	84	1	85	0	67	67	154
05:45 PM	0	3	3	93	3	96	0	56	56	155
Total	0	6	6	383	13	396	0	243	243	645
Grand Total	0	12	12	702	25	727	0	478	478	1217
Apprch %	0	100		96.6	3.4		0	100		
Total %	0	1	1	57.7	2.1	59.7	0	39.3	39.3	
Passenger Vehicles	0	12	12	698	25	723	0	476	476	1211
% Passenger Vehicles	0	100	100	99.4	100	99.4	0	99.6	99.6	99.5
Large 2 Axle Vehicles	0	0	0	3	0	3	0	2	2	5
% Large 2 Axle Vehicles	0	0	0	0.4	0	0.4	0	0.4	0.4	0.4
3 Axle Vehicles	0	0	0	1	0	1	0	0	0	1
% 3 Axle Vehicles	0	0	0	0.1	0	0.1	0	0	0	0.1
4+ Axle Trucks	0	0	0	0	0	0	0	0	0	0
% 4+ Axle Trucks	0	0	0	0	0	0	0	0	0	0

Start Time	Lytle Creek Road Southbound			Duncan Canyon Road Westbound			Duncan Canyon Road Eastbound			Int. Total
	Left	Right	App. Total	Thru	Right	App. Total	Left	Thru	App. Total	
Peak Hour Analysis From 04:00 PM to 05:45 PM - Peak 1 of 1										
Peak Hour for Entire Intersection Begins at 05:00 PM										
05:00 PM	0	1	1	97	3	100	0	55	55	156
05:15 PM	0	0	0	109	6	115	0	65	65	180
05:30 PM	0	2	2	84	1	85	0	67	67	154
05:45 PM	0	3	3	93	3	96	0	56	56	155
Total Volume	0	6	6	383	13	396	0	243	243	645
% App. Total	0	100		96.7	3.3		0	100		
PHF	.000	.500	.500	.878	.542	.861	.000	.907	.907	.896

County of San Bernardino
 N/S: Lytle Creek Road
 E/W: Duncan Canyon Road
 Weather: Clear

File Name : 02_CSB_Lytle Creek_Duncan Cyn PM
 Site Code : 12218022
 Start Date : 1/24/2018
 Page No : 2

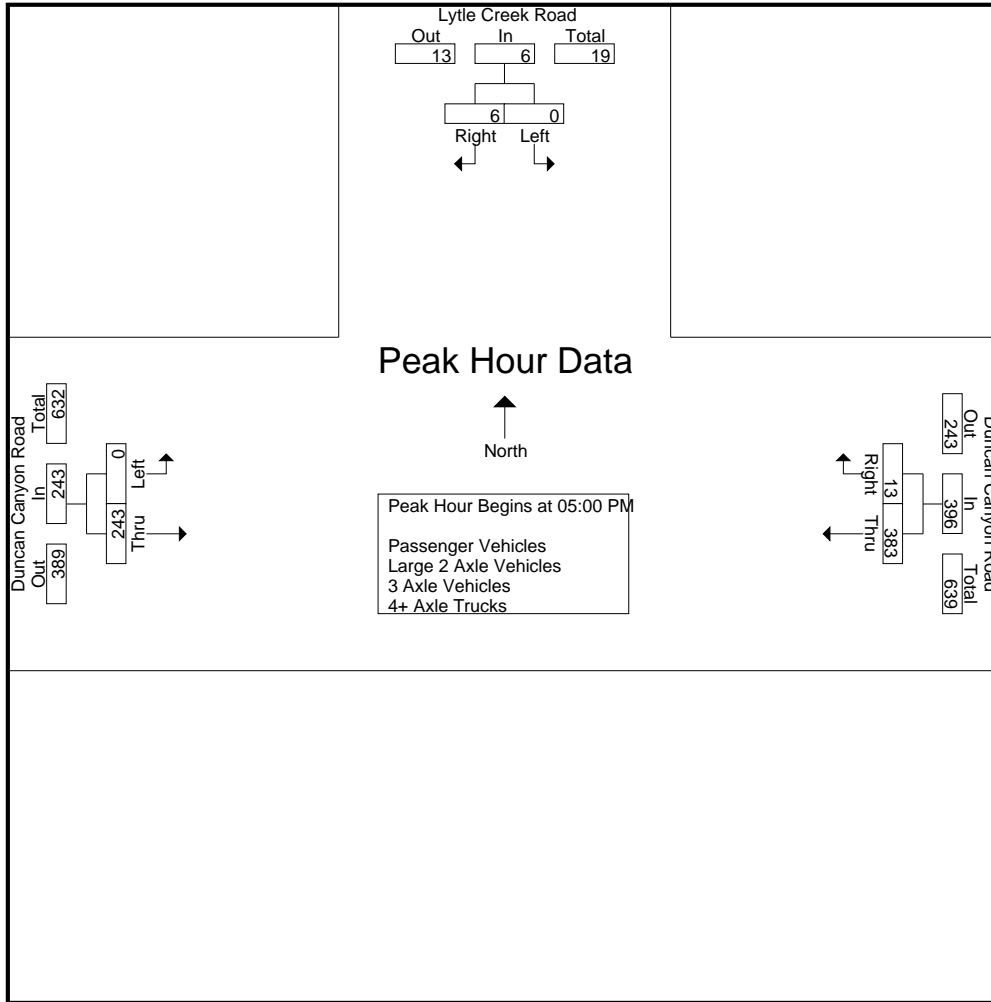

Peak Hour Analysis From 04:00 PM to 05:45 PM - Peak 1 of 1
 Peak Hour for Each Approach Begins at:

	04:00 PM			05:00 PM			04:30 PM		
+0 mins.	0	3	3	97	3	100	0	67	67
+15 mins.	0	1	1	109	6	115	0	57	57
+30 mins.	0	1	1	84	1	85	0	55	55
+45 mins.	0	1	1	93	3	96	0	65	65
Total Volume	0	6	6	383	13	396	0	244	244
% App. Total	0	100		96.7	3.3		0	100	
PHF	.000	.500	.500	.878	.542	.861	.000	.910	.910

County of San Bernardino
 N/S: Lytle Creek Road
 E/W: Duncan Canyon Road
 Weather: Clear

File Name : 02_CSB_Lytle Creek_Duncan Cyn PM
 Site Code : 12218022
 Start Date : 1/24/2018
 Page No : 1

Groups Printed- Passenger Vehicles

Start Time	Lytle Creek Road Southbound			Duncan Canyon Road Westbound			Duncan Canyon Road Eastbound			Int. Total
	Left	Right	App. Total	Thru	Right	App. Total	Left	Thru	App. Total	
04:00 PM	0	3	3	75	3	78	0	49	49	130
04:15 PM	0	1	1	87	5	92	0	61	61	154
04:30 PM	0	1	1	69	1	70	0	67	67	138
04:45 PM	0	1	1	86	3	89	0	56	56	146
Total	0	6	6	317	12	329	0	233	233	568
05:00 PM	0	1	1	96	3	99	0	55	55	155
05:15 PM	0	0	0	109	6	115	0	65	65	180
05:30 PM	0	2	2	84	1	85	0	67	67	154
05:45 PM	0	3	3	92	3	95	0	56	56	154
Total	0	6	6	381	13	394	0	243	243	643
Grand Total	0	12	12	698	25	723	0	476	476	1211
Apprch %	0	100		96.5	3.5		0	100		
Total %	0	1	1	57.6	2.1	59.7	0	39.3	39.3	

Start Time	Lytle Creek Road Southbound			Duncan Canyon Road Westbound			Duncan Canyon Road Eastbound			Int. Total
	Left	Right	App. Total	Thru	Right	App. Total	Left	Thru	App. Total	
05:00 PM	0	1	1	96	3	99	0	55	55	155
05:15 PM	0	0	0	109	6	115	0	65	65	180
05:30 PM	0	2	2	84	1	85	0	67	67	154
05:45 PM	0	3	3	92	3	95	0	56	56	154
Total Volume	0	6	6	381	13	394	0	243	243	643
% App. Total	0	100		96.7	3.3		0	100		
PHF	.000	.500	.500	.874	.542	.857	.000	.907	.907	.893

Peak Hour Analysis From 05:00 PM to 05:45 PM - Peak 1 of 1
 Peak Hour for Entire Intersection Begins at 05:00 PM

County of San Bernardino
 N/S: Lytle Creek Road
 E/W: Duncan Canyon Road
 Weather: Clear

File Name : 02_CSB_Lytle Creek_Duncan Cyn PM
 Site Code : 12218022
 Start Date : 1/24/2018
 Page No : 2

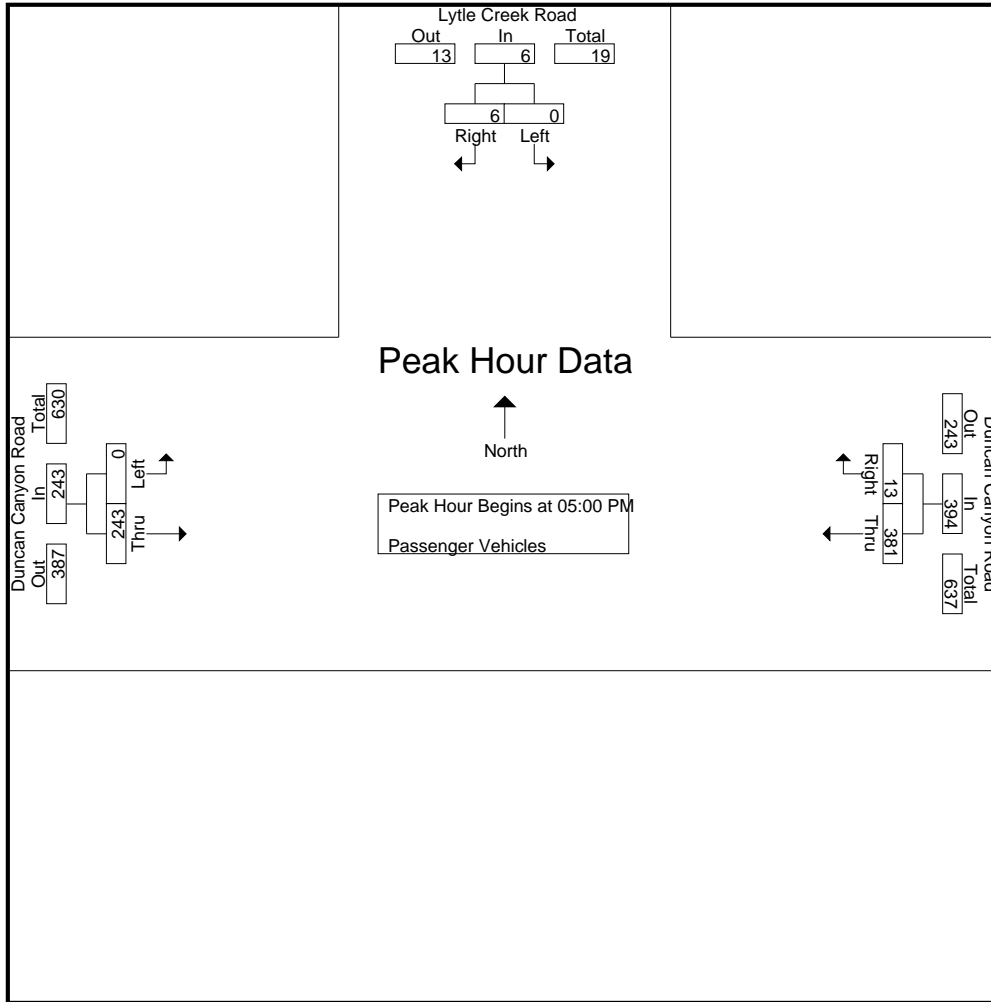

Peak Hour Analysis From 05:00 PM to 05:45 PM - Peak 1 of 1
 Peak Hour for Each Approach Begins at:

	05:00 PM			05:00 PM			05:00 PM		
+0 mins.	0	1	1	96	3	99	0	55	55
+15 mins.	0	0	0	109	6	115	0	65	65
+30 mins.	0	2	2	84	1	85	0	67	67
+45 mins.	0	3	3	92	3	95	0	56	56
Total Volume	0	6	6	381	13	394	0	243	243
% App. Total	0	100		96.7	3.3		0	100	
PHF	.000	.500	.500	.874	.542	.857	.000	.907	.907

County of San Bernardino
 N/S: Lytle Creek Road
 E/W: Duncan Canyon Road
 Weather: Clear

File Name : 02_CSB_Lytle Creek_Duncan Cyn PM
 Site Code : 12218022
 Start Date : 1/24/2018
 Page No : 1

Groups Printed- Large 2 Axle Vehicles

Start Time	Lytle Creek Road Southbound			Duncan Canyon Road Westbound			Duncan Canyon Road Eastbound			Int. Total
	Left	Right	App. Total	Thru	Right	App. Total	Left	Thru	App. Total	
04:00 PM	0	0	0	0	0	0	0	0	0	0
04:15 PM	0	0	0	2	0	2	0	1	1	3
04:30 PM	0	0	0	0	0	0	0	0	0	0
04:45 PM	0	0	0	0	0	0	0	1	1	1
Total	0	0	0	2	0	2	0	2	2	4
05:00 PM	0	0	0	0	0	0	0	0	0	0
05:15 PM	0	0	0	0	0	0	0	0	0	0
05:30 PM	0	0	0	0	0	0	0	0	0	0
05:45 PM	0	0	0	1	0	1	0	0	0	1
Total	0	0	0	1	0	1	0	0	0	1
Grand Total	0	0	0	3	0	3	0	2	2	5
Apprch %	0	0		100	0		0	100		
Total %	0	0		60	0	60	0	40	40	

Start Time	Lytle Creek Road Southbound			Duncan Canyon Road Westbound			Duncan Canyon Road Eastbound			Int. Total
	Left	Right	App. Total	Thru	Right	App. Total	Left	Thru	App. Total	
05:00 PM	0	0	0	0	0	0	0	0	0	0
05:15 PM	0	0	0	0	0	0	0	0	0	0
05:30 PM	0	0	0	0	0	0	0	0	0	0
05:45 PM	0	0	0	1	0	1	0	0	0	1
Total Volume	0	0	0	1	0	1	0	0	0	1
% App. Total	0	0		100	0		0	0		
PHF	.000	.000	.000	.250	.000	.250	.000	.000	.000	.250

Peak Hour Analysis From 05:00 PM to 05:45 PM - Peak 1 of 1
 Peak Hour for Entire Intersection Begins at 05:00 PM

County of San Bernardino
 N/S: Lytle Creek Road
 E/W: Duncan Canyon Road
 Weather: Clear

File Name : 02_CS_B_Lytle Creek_Duncan Cyn PM
 Site Code : 12218022
 Start Date : 1/24/2018
 Page No : 2

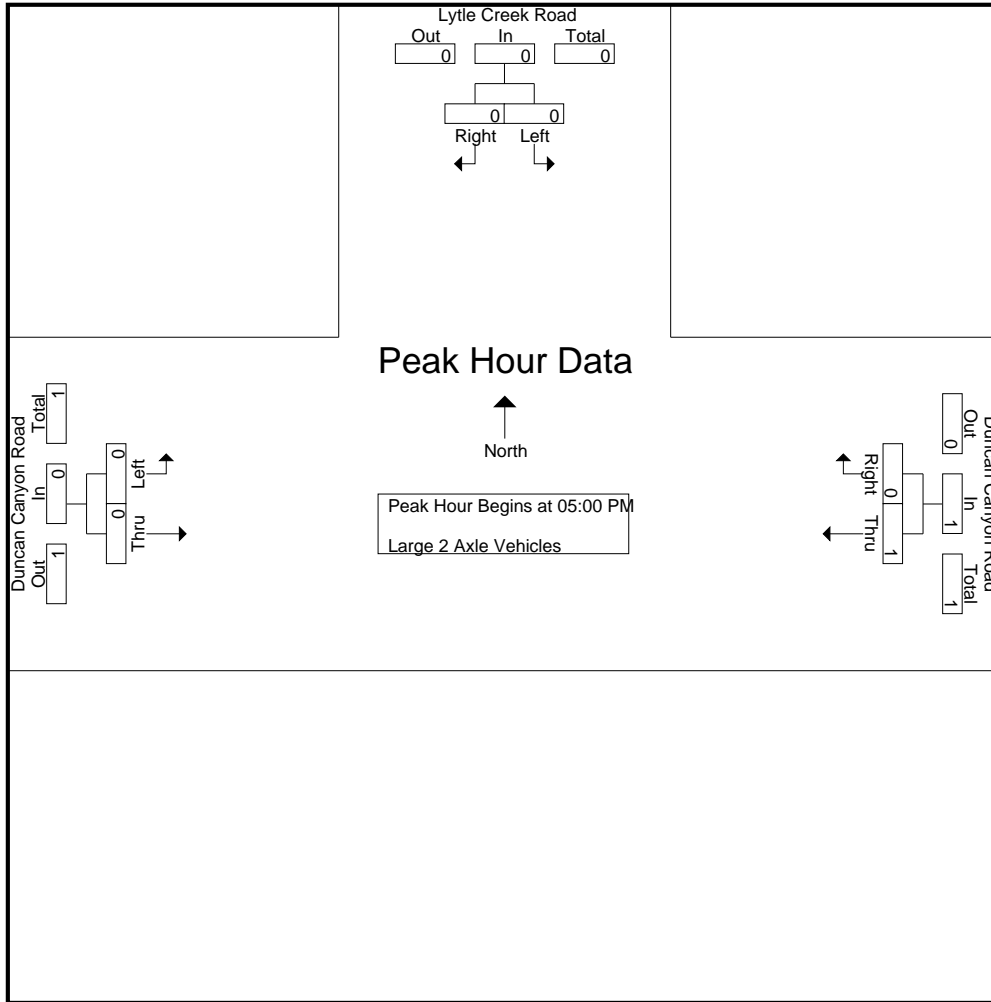

Peak Hour Analysis From 05:00 PM to 05:45 PM - Peak 1 of 1
 Peak Hour for Each Approach Begins at:

	05:00 PM			05:00 PM			05:00 PM		
+0 mins.	0	0	0	0	0	0	0	0	0
+15 mins.	0	0	0	0	0	0	0	0	0
+30 mins.	0	0	0	0	0	0	0	0	0
+45 mins.	0	0	0	1	0	1	0	0	0
Total Volume	0	0	0	1	0	1	0	0	0
% App. Total	0	0	0	100	0	100	0	0	0
PHF	.000	.000	.000	.250	.000	.250	.000	.000	.000

County of San Bernardino
 N/S: Lytle Creek Road
 E/W: Duncan Canyon Road
 Weather: Clear

File Name : 02_CSB_Lytle Creek_Duncan Cyn PM
 Site Code : 12218022
 Start Date : 1/24/2018
 Page No : 1

Groups Printed- 3 Axle Vehicles

Start Time	Lytle Creek Road Southbound			Duncan Canyon Road Westbound			Duncan Canyon Road Eastbound			Int. Total
	Left	Right	App. Total	Thru	Right	App. Total	Left	Thru	App. Total	
04:00 PM	0	0	0	0	0	0	0	0	0	0
04:15 PM	0	0	0	0	0	0	0	0	0	0
04:30 PM	0	0	0	0	0	0	0	0	0	0
04:45 PM	0	0	0	0	0	0	0	0	0	0
Total	0	0	0	0	0	0	0	0	0	0
05:00 PM	0	0	0	1	0	1	0	0	0	1
05:15 PM	0	0	0	0	0	0	0	0	0	0
05:30 PM	0	0	0	0	0	0	0	0	0	0
05:45 PM	0	0	0	0	0	0	0	0	0	0
Total	0	0	0	1	0	1	0	0	0	1
Grand Total	0	0	0	1	0	1	0	0	0	1
Apprch %	0	0		100	0		0	0		
Total %	0	0		100	0	100	0	0		

Start Time	Lytle Creek Road Southbound			Duncan Canyon Road Westbound			Duncan Canyon Road Eastbound			Int. Total
	Left	Right	App. Total	Thru	Right	App. Total	Left	Thru	App. Total	
05:00 PM	0	0	0	1	0	1	0	0	0	1
05:15 PM	0	0	0	0	0	0	0	0	0	0
05:30 PM	0	0	0	0	0	0	0	0	0	0
05:45 PM	0	0	0	0	0	0	0	0	0	0
Total Volume	0	0	0	1	0	1	0	0	0	1
% App. Total	0	0		100	0		0	0		
PHF	.000	.000	.000	.250	.000	.250	.000	.000	.000	.250

Peak Hour Analysis From 05:00 PM to 05:45 PM - Peak 1 of 1

Peak Hour for Entire Intersection Begins at 05:00 PM

County of San Bernardino
 N/S: Lytle Creek Road
 E/W: Duncan Canyon Road
 Weather: Clear

File Name : 02_CS_B_Lytle Creek_Duncan Cyn PM
 Site Code : 12218022
 Start Date : 1/24/2018
 Page No : 2

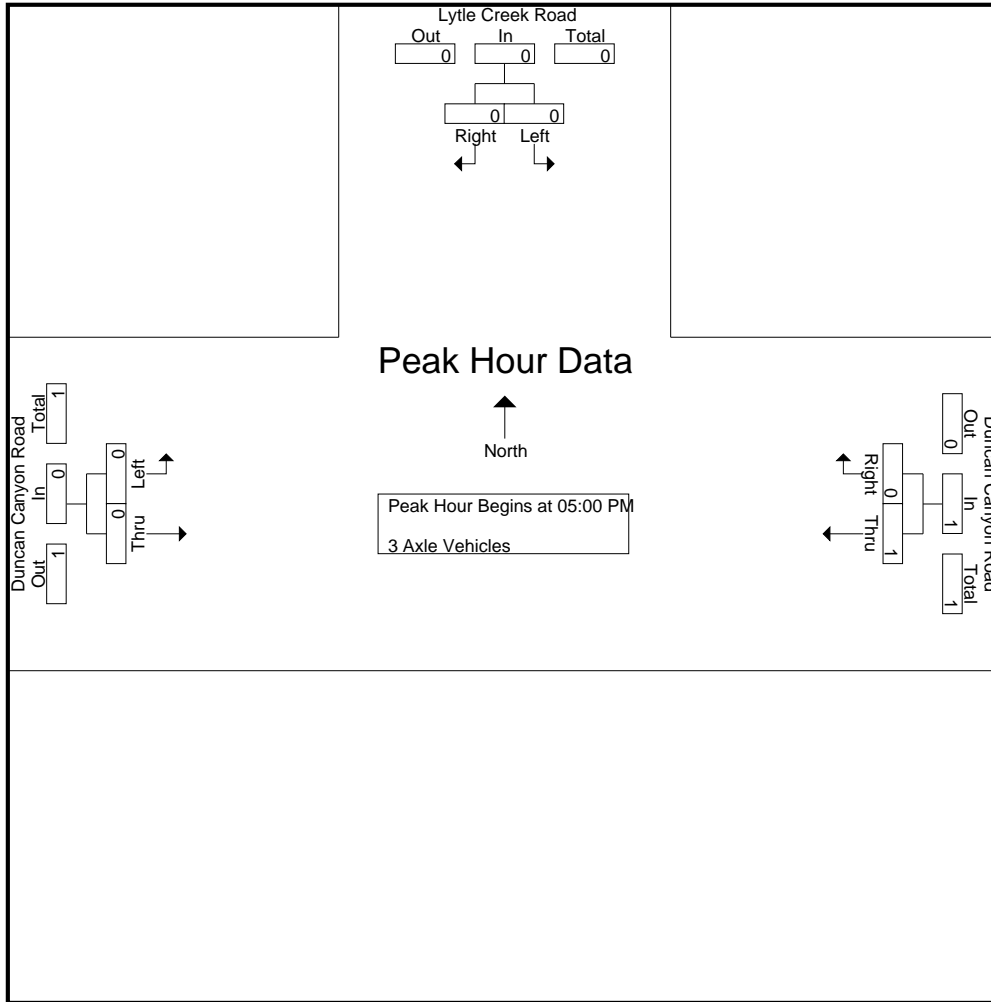

Peak Hour Analysis From 05:00 PM to 05:45 PM - Peak 1 of 1
 Peak Hour for Each Approach Begins at:

	05:00 PM			05:00 PM			05:00 PM		
+0 mins.	0	0	0	1	0	1	0	0	0
+15 mins.	0	0	0	0	0	0	0	0	0
+30 mins.	0	0	0	0	0	0	0	0	0
+45 mins.	0	0	0	0	0	0	0	0	0
Total Volume	0	0	0	1	0	1	0	0	0
% App. Total	0	0	0	100	0	100	0	0	0
PHF	.000	.000	.000	.250	.000	.250	.000	.000	.000

County of San Bernardino
 N/S: Lytle Creek Road/Sierra Avenue
 E/W: Lytle Creek Road
 Weather: Clear

File Name : 03_CSB_Sierra_Lytle Creek AM
 Site Code : 12218022
 Start Date : 1/24/2018
 Page No : 1

Groups Printed- Passenger Vehicles - Large 2 Axle Vehicles - 3 Axle Vehicles - 4+ Axle Trucks

Start Time	Lytle Creek Road Southbound			Sierra Avenue Northbound			Lytle Creek Road Eastbound			Int. Total
	Thru	Right	App. Total	Left	Thru	App. Total	Left	Right	App. Total	
07:00 AM	212	4	216	1	65	66	0	3	3	285
07:15 AM	251	4	255	7	86	93	0	1	1	349
07:30 AM	240	2	242	3	73	76	3	4	7	325
07:45 AM	153	3	156	3	53	56	1	2	3	215
Total	856	13	869	14	277	291	4	10	14	1174
08:00 AM	119	0	119	4	61	65	1	4	5	189
08:15 AM	122	0	122	0	70	70	3	2	5	197
08:30 AM	107	1	108	2	53	55	0	5	5	168
08:45 AM	108	2	110	1	53	54	0	3	3	167
Total	456	3	459	7	237	244	4	14	18	721
Grand Total	1312	16	1328	21	514	535	8	24	32	1895
Apprch %	98.8	1.2		3.9	96.1		25	75		
Total %	69.2	0.8	70.1	1.1	27.1	28.2	0.4	1.3	1.7	
Passenger Vehicles	1277	16	1293	19	484	503	7	22	29	1825
% Passenger Vehicles	97.3	100	97.4	90.5	94.2	94	87.5	91.7	90.6	96.3
Large 2 Axle Vehicles	14	0	14	1	12	13	1	1	2	29
% Large 2 Axle Vehicles	1.1	0	1.1	4.8	2.3	2.4	12.5	4.2	6.2	1.5
3 Axle Vehicles	11	0	11	0	9	9	0	0	0	20
% 3 Axle Vehicles	0.8	0	0.8	0	1.8	1.7	0	0	0	1.1
4+ Axle Trucks	10	0	10	1	9	10	0	1	1	21
% 4+ Axle Trucks	0.8	0	0.8	4.8	1.8	1.9	0	4.2	3.1	1.1

Start Time	Lytle Creek Road Southbound			Sierra Avenue Northbound			Lytle Creek Road Eastbound			Int. Total
	Thru	Right	App. Total	Left	Thru	App. Total	Left	Right	App. Total	
07:00 AM	212	4	216	1	65	66	0	3	3	285
07:15 AM	251	4	255	7	86	93	0	1	1	349
07:30 AM	240	2	242	3	73	76	3	4	7	325
07:45 AM	153	3	156	3	53	56	1	2	3	215
Total Volume	856	13	869	14	277	291	4	10	14	1174
% App. Total	98.5	1.5		4.8	95.2		28.6	71.4		
PHF	.853	.813	.852	.500	.805	.782	.333	.625	.500	.841

Peak Hour Analysis From 07:00 AM to 08:45 AM - Peak 1 of 1
 Peak Hour for Entire Intersection Begins at 07:00 AM

County of San Bernardino
 N/S: Lytle Creek Road/Sierra Avenue
 E/W: Lytle Creek Road
 Weather: Clear

File Name : 03_CSB_Sierra_Lytle Creek AM
 Site Code : 12218022
 Start Date : 1/24/2018
 Page No : 2

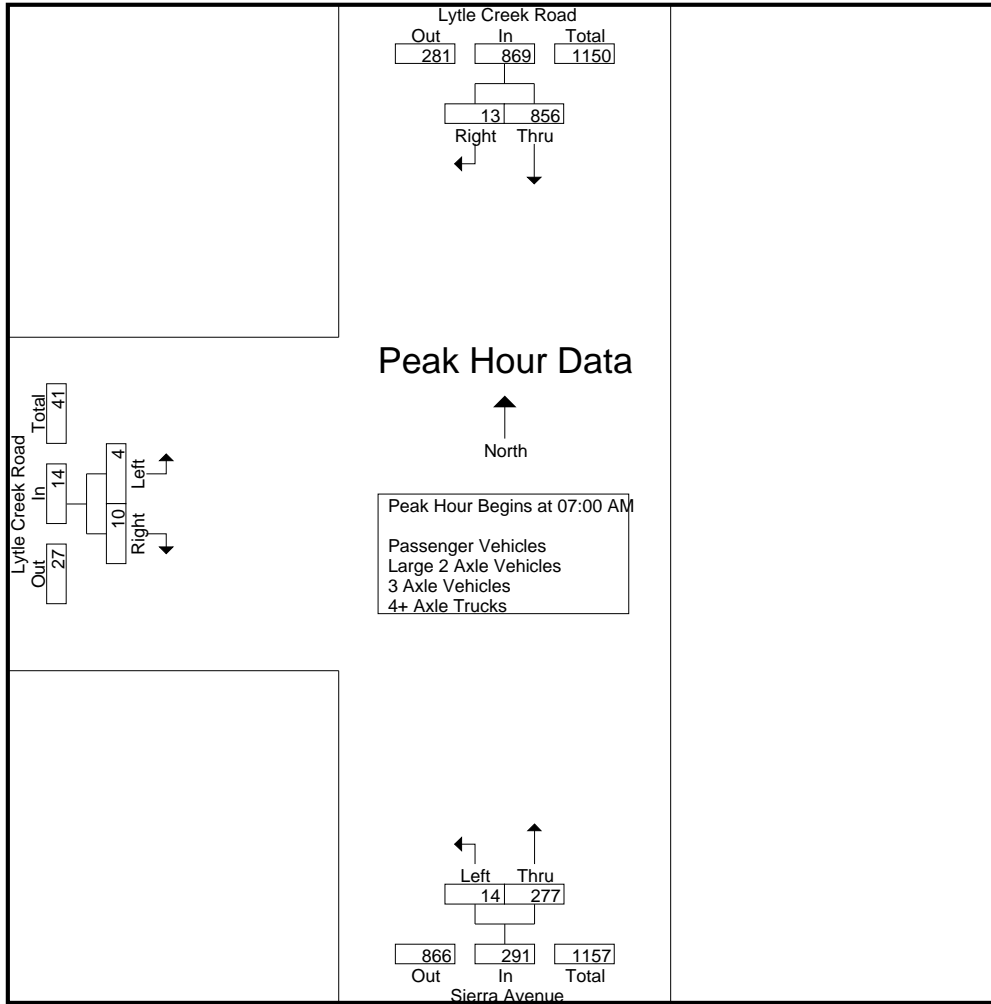

Peak Hour Analysis From 07:00 AM to 08:45 AM - Peak 1 of 1
 Peak Hour for Each Approach Begins at:

	07:00 AM			07:00 AM			07:30 AM		
+0 mins.	212	4	216	1	65	66	3	4	7
+15 mins.	251	4	255	7	86	93	1	2	3
+30 mins.	240	2	242	3	73	76	1	4	5
+45 mins.	153	3	156	3	53	56	3	2	5
Total Volume	856	13	869	14	277	291	8	12	20
% App. Total	98.5	1.5		4.8	95.2		40	60	
PHF	.853	.813	.852	.500	.805	.782	.667	.750	.714

County of San Bernardino
 N/S: Lytle Creek Road/Sierra Avenue
 E/W: Lytle Creek Road
 Weather: Clear

File Name : 03_CSB_Sierra_Lytle Creek AM
 Site Code : 12218022
 Start Date : 1/24/2018
 Page No : 1

Groups Printed- Passenger Vehicles

Start Time	Lytle Creek Road Southbound			Sierra Avenue Northbound			Lytle Creek Road Eastbound			Int. Total
	Thru	Right	App. Total	Left	Thru	App. Total	Left	Right	App. Total	
07:00 AM	206	4	210	1	60	61	0	3	3	274
07:15 AM	246	4	250	5	82	87	0	1	1	338
07:30 AM	237	2	239	3	69	72	3	4	7	318
07:45 AM	142	3	145	3	50	53	1	2	3	201
Total	831	13	844	12	261	273	4	10	14	1131
08:00 AM	116	0	116	4	59	63	1	3	4	183
08:15 AM	118	0	118	0	64	64	2	1	3	185
08:30 AM	106	1	107	2	49	51	0	5	5	163
08:45 AM	106	2	108	1	51	52	0	3	3	163
Total	446	3	449	7	223	230	3	12	15	694
Grand Total	1277	16	1293	19	484	503	7	22	29	1825
Apprch %	98.8	1.2		3.8	96.2		24.1	75.9		
Total %	70	0.9	70.8	1	26.5	27.6	0.4	1.2	1.6	

Start Time	Lytle Creek Road Southbound			Sierra Avenue Northbound			Lytle Creek Road Eastbound			Int. Total
	Thru	Right	App. Total	Left	Thru	App. Total	Left	Right	App. Total	
07:00 AM	206	4	210	1	60	61	0	3	3	274
07:15 AM	246	4	250	5	82	87	0	1	1	338
07:30 AM	237	2	239	3	69	72	3	4	7	318
07:45 AM	142	3	145	3	50	53	1	2	3	201
Total Volume	831	13	844	12	261	273	4	10	14	1131
% App. Total	98.5	1.5		4.4	95.6		28.6	71.4		
PHF	.845	.813	.844	.600	.796	.784	.333	.625	.500	.837

Peak Hour Analysis From 07:00 AM to 07:45 AM - Peak 1 of 1

Peak Hour for Entire Intersection Begins at 07:00 AM

County of San Bernardino
 N/S: Lytle Creek Road/Sierra Avenue
 E/W: Lytle Creek Road
 Weather: Clear

File Name : 03_CSB_Sierra_Lytle Creek AM
 Site Code : 12218022
 Start Date : 1/24/2018
 Page No : 2

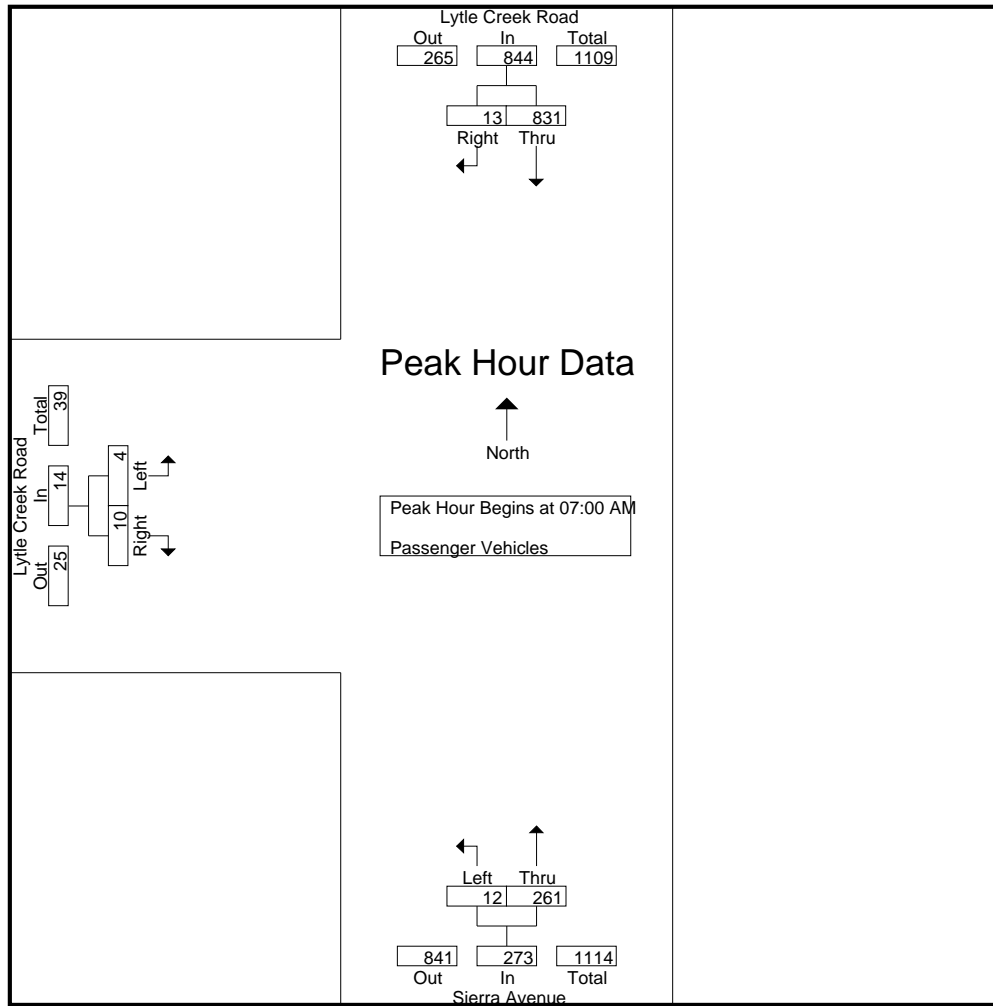

Peak Hour Analysis From 07:00 AM to 07:45 AM - Peak 1 of 1
 Peak Hour for Each Approach Begins at:

	07:00 AM			07:00 AM			07:00 AM		
+0 mins.	206	4	210	1	60	61	0	3	3
+15 mins.	246	4	250	5	82	87	0	1	1
+30 mins.	237	2	239	3	69	72	3	4	7
+45 mins.	142	3	145	3	50	53	1	2	3
Total Volume	831	13	844	12	261	273	4	10	14
% App. Total	98.5	1.5		4.4	95.6		28.6	71.4	
PHF	.845	.813	.844	.600	.796	.784	.333	.625	.500

County of San Bernardino
 N/S: Lytle Creek Road/Sierra Avenue
 E/W: Lytle Creek Road
 Weather: Clear

File Name : 03_CSB_Sierra_Lytle Creek AM
 Site Code : 12218022
 Start Date : 1/24/2018
 Page No : 1

Groups Printed- Large 2 Axle Vehicles

Start Time	Lytle Creek Road Southbound			Sierra Avenue Northbound			Lytle Creek Road Eastbound			Int. Total
	Thru	Right	App. Total	Left	Thru	App. Total	Left	Right	App. Total	
07:00 AM	5	0	5	0	3	3	0	0	0	8
07:15 AM	3	0	3	1	3	4	0	0	0	7
07:30 AM	1	0	1	0	1	1	0	0	0	2
07:45 AM	4	0	4	0	1	1	0	0	0	5
Total	13	0	13	1	8	9	0	0	0	22
08:00 AM	0	0	0	0	0	0	0	1	1	1
08:15 AM	1	0	1	0	2	2	1	0	1	4
08:30 AM	0	0	0	0	0	0	0	0	0	0
08:45 AM	0	0	0	0	2	2	0	0	0	2
Total	1	0	1	0	4	4	1	1	2	7
Grand Total	14	0	14	1	12	13	1	1	2	29
Apprch %	100	0		7.7	92.3		50	50		
Total %	48.3	0	48.3	3.4	41.4	44.8	3.4	3.4	6.9	

Start Time	Lytle Creek Road Southbound			Sierra Avenue Northbound			Lytle Creek Road Eastbound			Int. Total
	Thru	Right	App. Total	Left	Thru	App. Total	Left	Right	App. Total	
07:00 AM	5	0	5	0	3	3	0	0	0	8
07:15 AM	3	0	3	1	3	4	0	0	0	7
07:30 AM	1	0	1	0	1	1	0	0	0	2
07:45 AM	4	0	4	0	1	1	0	0	0	5
Total Volume	13	0	13	1	8	9	0	0	0	22
% App. Total	100	0		11.1	88.9		0	0		
PHF	.650	.000	.650	.250	.667	.563	.000	.000	.000	.688

Peak Hour Analysis From 07:00 AM to 07:45 AM - Peak 1 of 1

Peak Hour for Entire Intersection Begins at 07:00 AM

County of San Bernardino
 N/S: Lytle Creek Road/Sierra Avenue
 E/W: Lytle Creek Road
 Weather: Clear

File Name : 03_CSB_Sierra_Lytle Creek AM
 Site Code : 12218022
 Start Date : 1/24/2018
 Page No : 2

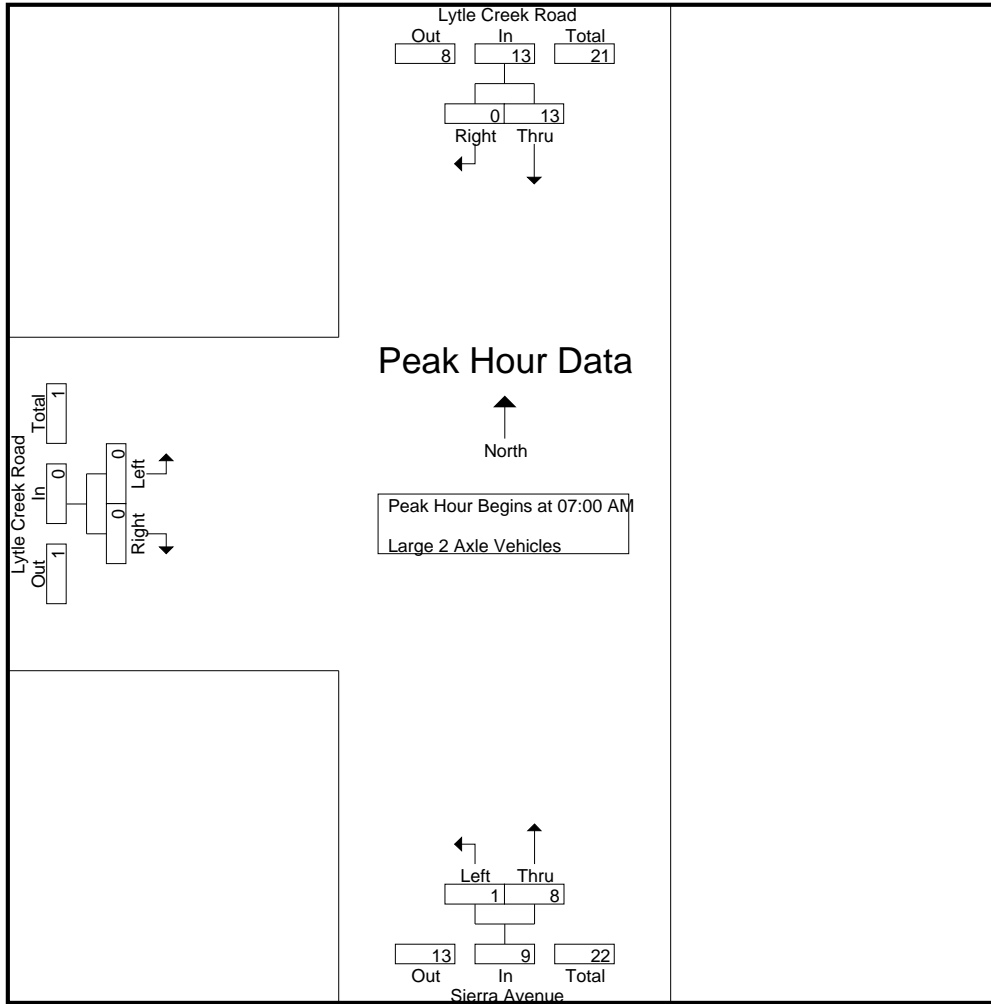

Peak Hour Analysis From 07:00 AM to 07:45 AM - Peak 1 of 1
 Peak Hour for Each Approach Begins at:

	07:00 AM			07:00 AM			07:00 AM		
+0 mins.	5	0	5	0	3	3	0	0	0
+15 mins.	3	0	3	1	3	4	0	0	0
+30 mins.	1	0	1	0	1	1	0	0	0
+45 mins.	4	0	4	0	1	1	0	0	0
Total Volume	13	0	13	1	8	9	0	0	0
% App. Total	100	0		11.1	88.9		0	0	
PHF	.650	.000	.650	.250	.667	.563	.000	.000	.000

County of San Bernardino
 N/S: Lytle Creek Road/Sierra Avenue
 E/W: Lytle Creek Road
 Weather: Clear

File Name : 03_CSB_Sierra_Lytle Creek AM
 Site Code : 12218022
 Start Date : 1/24/2018
 Page No : 1

Groups Printed- 3 Axle Vehicles

Start Time	Lytle Creek Road Southbound			Sierra Avenue Northbound			Lytle Creek Road Eastbound			Int. Total
	Thru	Right	App. Total	Left	Thru	App. Total	Left	Right	App. Total	
07:00 AM	0	0	0	0	2	2	0	0	0	2
07:15 AM	1	0	1	0	0	0	0	0	0	1
07:30 AM	1	0	1	0	2	2	0	0	0	3
07:45 AM	3	0	3	0	2	2	0	0	0	5
Total	5	0	5	0	6	6	0	0	0	11
08:00 AM	1	0	1	0	0	0	0	0	0	1
08:15 AM	3	0	3	0	2	2	0	0	0	5
08:30 AM	1	0	1	0	1	1	0	0	0	2
08:45 AM	1	0	1	0	0	0	0	0	0	1
Total	6	0	6	0	3	3	0	0	0	9
Grand Total	11	0	11	0	9	9	0	0	0	20
Apprch %	100	0		0	100		0	0		
Total %	55	0	55	0	45	45	0	0	0	

Start Time	Lytle Creek Road Southbound			Sierra Avenue Northbound			Lytle Creek Road Eastbound			Int. Total
	Thru	Right	App. Total	Left	Thru	App. Total	Left	Right	App. Total	
07:00 AM	0	0	0	0	2	2	0	0	0	2
07:15 AM	1	0	1	0	0	0	0	0	0	1
07:30 AM	1	0	1	0	2	2	0	0	0	3
07:45 AM	3	0	3	0	2	2	0	0	0	5
Total Volume	5	0	5	0	6	6	0	0	0	11
% App. Total	100	0		0	100		0	0		
PHF	.417	.000	.417	.000	.750	.750	.000	.000	.000	.550

Peak Hour Analysis From 07:00 AM to 07:45 AM - Peak 1 of 1

Peak Hour for Entire Intersection Begins at 07:00 AM

County of San Bernardino
 N/S: Lytle Creek Road/Sierra Avenue
 E/W: Lytle Creek Road
 Weather: Clear

File Name : 03_CSB_Sierra_Lytle Creek AM
 Site Code : 12218022
 Start Date : 1/24/2018
 Page No : 2

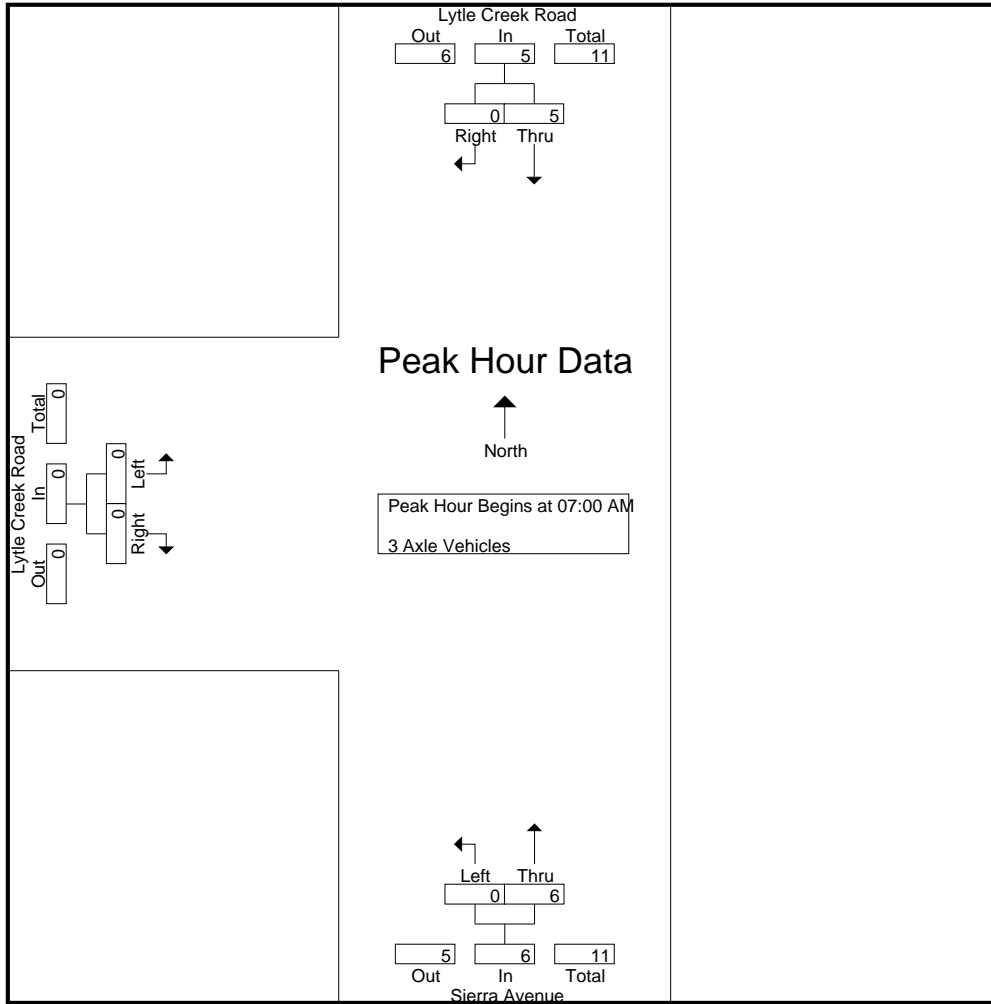

Peak Hour Analysis From 07:00 AM to 07:45 AM - Peak 1 of 1
 Peak Hour for Each Approach Begins at:

	07:00 AM			07:00 AM			07:00 AM		
+0 mins.	0	0	0	0	2	2	0	0	0
+15 mins.	1	0	1	0	0	0	0	0	0
+30 mins.	1	0	1	0	2	2	0	0	0
+45 mins.	3	0	3	0	2	2	0	0	0
Total Volume	5	0	5	0	6	6	0	0	0
% App. Total	100	0		0	100		0	0	
PHF	.417	.000	.417	.000	.750	.750	.000	.000	.000

County of San Bernardino
 N/S: Lytle Creek Road/Sierra Avenue
 E/W: Lytle Creek Road
 Weather: Clear

File Name : 03_CSB_Sierra_Lytle Creek AM
 Site Code : 12218022
 Start Date : 1/24/2018
 Page No : 1

Groups Printed- 4+ Axle Trucks

Start Time	Lytle Creek Road Southbound			Sierra Avenue Northbound			Lytle Creek Road Eastbound			Int. Total
	Thru	Right	App. Total	Left	Thru	App. Total	Left	Right	App. Total	
07:00 AM	1	0	1	0	0	0	0	0	0	1
07:15 AM	1	0	1	1	1	2	0	0	0	3
07:30 AM	1	0	1	0	1	1	0	0	0	2
07:45 AM	4	0	4	0	0	0	0	0	0	4
Total	7	0	7	1	2	3	0	0	0	10
08:00 AM	2	0	2	0	2	2	0	0	0	4
08:15 AM	0	0	0	0	2	2	0	1	1	3
08:30 AM	0	0	0	0	3	3	0	0	0	3
08:45 AM	1	0	1	0	0	0	0	0	0	1
Total	3	0	3	0	7	7	0	1	1	11
Grand Total	10	0	10	1	9	10	0	1	1	21
Apprch %	100	0		10	90		0	100		
Total %	47.6	0	47.6	4.8	42.9	47.6	0	4.8	4.8	

Start Time	Lytle Creek Road Southbound			Sierra Avenue Northbound			Lytle Creek Road Eastbound			Int. Total
	Thru	Right	App. Total	Left	Thru	App. Total	Left	Right	App. Total	
07:00 AM	1	0	1	0	0	0	0	0	0	1
07:15 AM	1	0	1	1	1	2	0	0	0	3
07:30 AM	1	0	1	0	1	1	0	0	0	2
07:45 AM	4	0	4	0	0	0	0	0	0	4
Total Volume	7	0	7	1	2	3	0	0	0	10
% App. Total	100	0		33.3	66.7		0	0		
PHF	.438	.000	.438	.250	.500	.375	.000	.000	.000	.625

Peak Hour Analysis From 07:00 AM to 07:45 AM - Peak 1 of 1

Peak Hour for Entire Intersection Begins at 07:00 AM

County of San Bernardino
 N/S: Lytle Creek Road/Sierra Avenue
 E/W: Lytle Creek Road
 Weather: Clear

File Name : 03_CSB_Sierra_Lytle Creek AM
 Site Code : 12218022
 Start Date : 1/24/2018
 Page No : 2

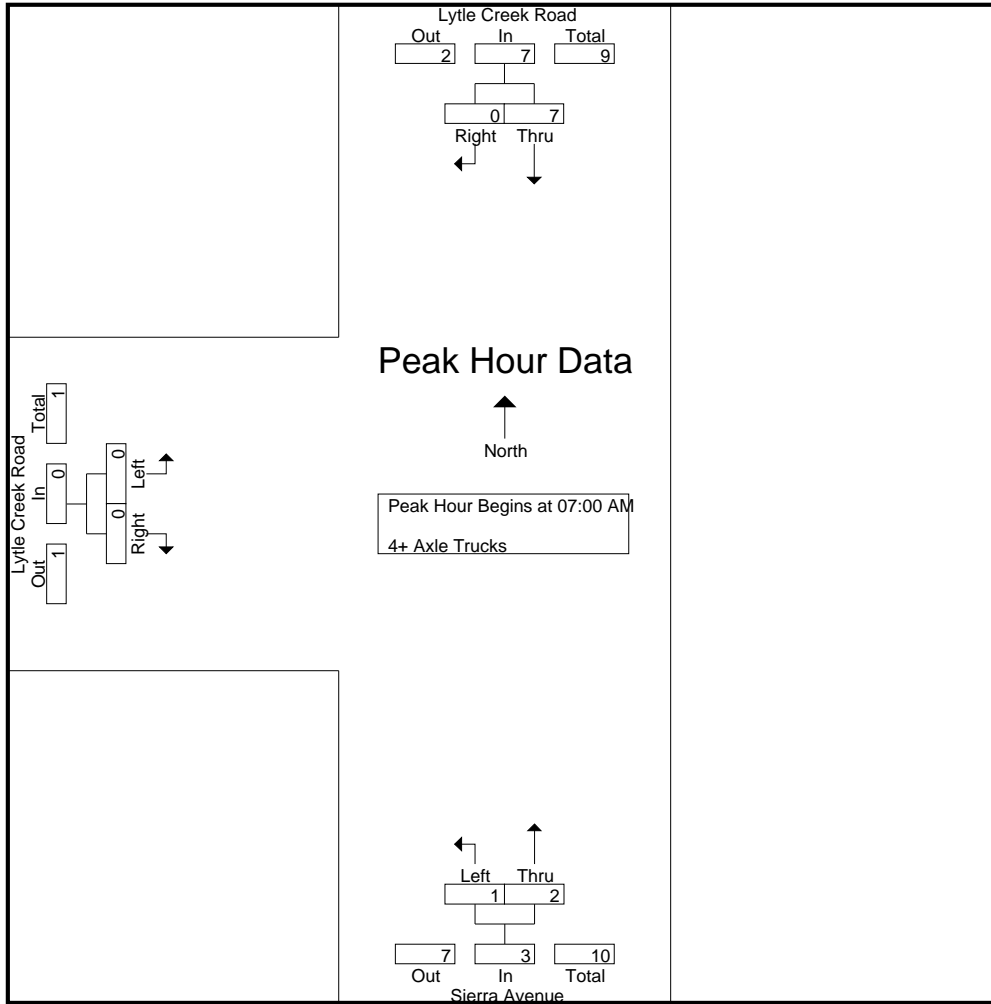

Peak Hour Analysis From 07:00 AM to 07:45 AM - Peak 1 of 1
 Peak Hour for Each Approach Begins at:

	07:00 AM			07:00 AM			07:00 AM		
+0 mins.	1	0	1	0	0	0	0	0	0
+15 mins.	1	0	1	1	1	2	0	0	0
+30 mins.	1	0	1	0	1	1	0	0	0
+45 mins.	4	0	4	0	0	0	0	0	0
Total Volume	7	0	7	1	2	3	0	0	0
% App. Total	100	0		33.3	66.7		0	0	
PHF	.438	.000	.438	.250	.500	.375	.000	.000	.000

County of San Bernardino
 N/S: Lytle Creek Road/Sierra Avenue
 E/W: Lytle Creek Road
 Weather: Clear

File Name : 03_CSB_Sierra_Lytle Creek PM
 Site Code : 12218022
 Start Date : 1/24/2018
 Page No : 1

Groups Printed- Passenger Vehicles - Large 2 Axle Vehicles - 3 Axle Vehicles - 4+ Axle Trucks

Start Time	Lytle Creek Road Southbound			Sierra Avenue Northbound			Lytle Creek Road Eastbound			Int. Total
	Thru	Right	App. Total	Left	Thru	App. Total	Left	Right	App. Total	
04:00 PM	88	2	90	9	123	132	4	2	6	228
04:15 PM	97	1	98	4	133	137	5	2	7	242
04:30 PM	102	1	103	5	151	156	2	4	6	265
04:45 PM	94	1	95	10	143	153	4	6	10	258
Total	381	5	386	28	550	578	15	14	29	993
05:00 PM	98	1	99	2	143	145	5	6	11	255
05:15 PM	97	0	97	7	167	174	3	6	9	280
05:30 PM	87	1	88	6	156	162	6	3	9	259
05:45 PM	92	3	95	3	160	163	1	3	4	262
Total	374	5	379	18	626	644	15	18	33	1056
Grand Total	755	10	765	46	1176	1222	30	32	62	2049
Apprch %	98.7	1.3		3.8	96.2		48.4	51.6		
Total %	36.8	0.5	37.3	2.2	57.4	59.6	1.5	1.6	3	
Passenger Vehicles	740	10	750	46	1166	1212	30	31	61	2023
% Passenger Vehicles	98	100	98	100	99.1	99.2	100	96.9	98.4	98.7
Large 2 Axle Vehicles	8	0	8	0	5	5	0	1	1	14
% Large 2 Axle Vehicles	1.1	0	1	0	0.4	0.4	0	3.1	1.6	0.7
3 Axle Vehicles	1	0	1	0	0	0	0	0	0	1
% 3 Axle Vehicles	0.1	0	0.1	0	0	0	0	0	0	0
4+ Axle Trucks	6	0	6	0	5	5	0	0	0	11
% 4+ Axle Trucks	0.8	0	0.8	0	0.4	0.4	0	0	0	0.5

Start Time	Lytle Creek Road Southbound			Sierra Avenue Northbound			Lytle Creek Road Eastbound			Int. Total
	Thru	Right	App. Total	Left	Thru	App. Total	Left	Right	App. Total	
04:30 PM	102	1	103	5	151	156	2	4	6	265
04:45 PM	94	1	95	10	143	153	4	6	10	258
05:00 PM	98	1	99	2	143	145	5	6	11	255
05:15 PM	97	0	97	7	167	174	3	6	9	280
Total Volume	391	3	394	24	604	628	14	22	36	1058
% App. Total	99.2	0.8		3.8	96.2		38.9	61.1		
PHF	.958	.750	.956	.600	.904	.902	.700	.917	.818	.945

Peak Hour Analysis From 04:00 PM to 05:45 PM - Peak 1 of 1
 Peak Hour for Entire Intersection Begins at 04:30 PM

County of San Bernardino
 N/S: Lytle Creek Road/Sierra Avenue
 E/W: Lytle Creek Road
 Weather: Clear

File Name : 03_CSB_Sierra_Lytle Creek PM
 Site Code : 12218022
 Start Date : 1/24/2018
 Page No : 2

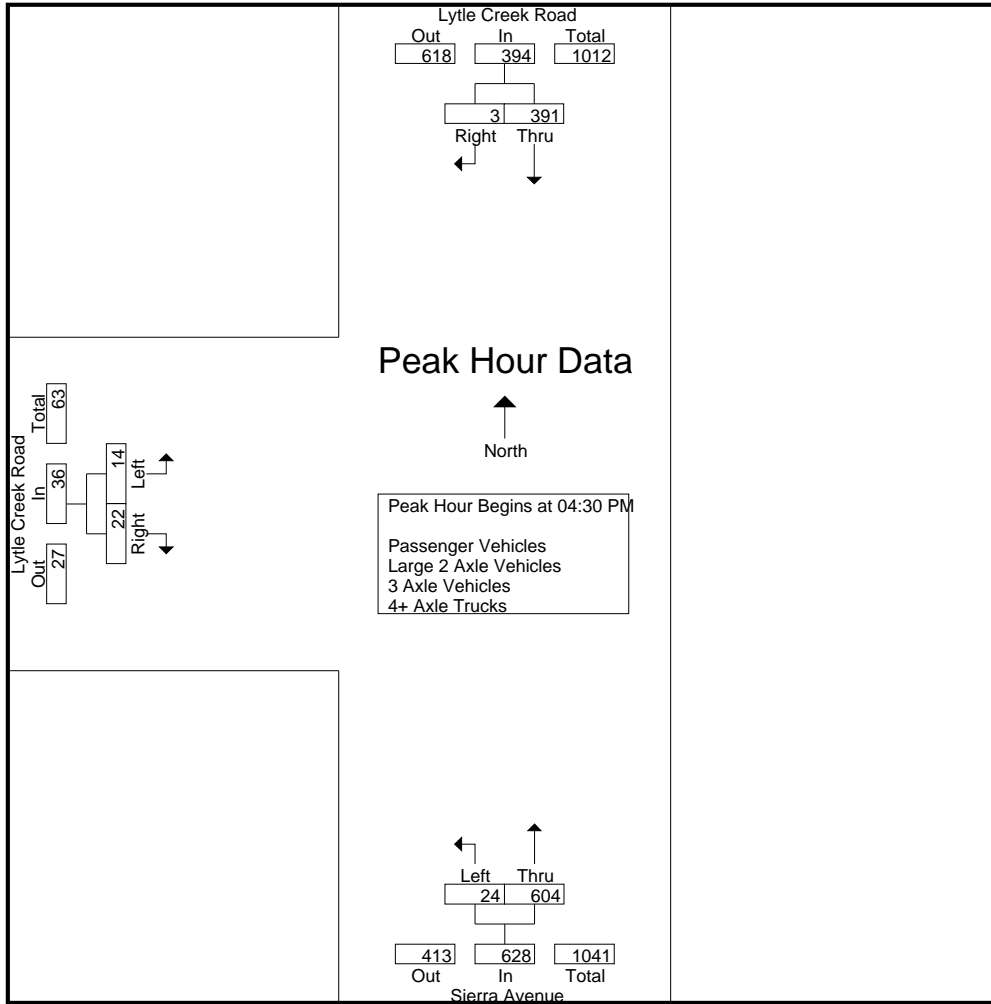

Peak Hour Analysis From 04:00 PM to 05:45 PM - Peak 1 of 1
 Peak Hour for Each Approach Begins at:

	04:15 PM			05:00 PM			04:45 PM		
+0 mins.	97	1	98	2	143	145	4	6	10
+15 mins.	102	1	103	7	167	174	5	6	11
+30 mins.	94	1	95	6	156	162	3	6	9
+45 mins.	98	1	99	3	160	163	6	3	9
Total Volume	391	4	395	18	626	644	18	21	39
% App. Total	99	1		2.8	97.2		46.2	53.8	
PHF	.958	1.000	.959	.643	.937	.925	.750	.875	.886

County of San Bernardino
 N/S: Lytle Creek Road/Sierra Avenue
 E/W: Lytle Creek Road
 Weather: Clear

File Name : 03_CSB_Sierra_Lytle Creek PM
 Site Code : 12218022
 Start Date : 1/24/2018
 Page No : 1

Groups Printed- Passenger Vehicles

Start Time	Lytle Creek Road Southbound			Sierra Avenue Northbound			Lytle Creek Road Eastbound			Int. Total
	Thru	Right	App. Total	Left	Thru	App. Total	Left	Right	App. Total	
04:00 PM	86	2	88	9	123	132	4	2	6	226
04:15 PM	95	1	96	4	131	135	5	2	7	238
04:30 PM	99	1	100	5	149	154	2	3	5	259
04:45 PM	94	1	95	10	143	153	4	6	10	258
Total	374	5	379	28	546	574	15	13	28	981
05:00 PM	95	1	96	2	142	144	5	6	11	251
05:15 PM	94	0	94	7	166	173	3	6	9	276
05:30 PM	86	1	87	6	155	161	6	3	9	257
05:45 PM	91	3	94	3	157	160	1	3	4	258
Total	366	5	371	18	620	638	15	18	33	1042
Grand Total	740	10	750	46	1166	1212	30	31	61	2023
Apprch %	98.7	1.3		3.8	96.2		49.2	50.8		
Total %	36.6	0.5	37.1	2.3	57.6	59.9	1.5	1.5	3	

Start Time	Lytle Creek Road Southbound			Sierra Avenue Northbound			Lytle Creek Road Eastbound			Int. Total
	Thru	Right	App. Total	Left	Thru	App. Total	Left	Right	App. Total	
04:30 PM	99	1	100	5	149	154	2	3	5	259
04:45 PM	94	1	95	10	143	153	4	6	10	258
05:00 PM	95	1	96	2	142	144	5	6	11	251
05:15 PM	94	0	94	7	166	173	3	6	9	276
Total Volume	382	3	385	24	600	624	14	21	35	1044
% App. Total	99.2	0.8		3.8	96.2		40	60		
PHF	.965	.750	.963	.600	.904	.902	.700	.875	.795	.946

Peak Hour Analysis From 04:30 PM to 05:15 PM - Peak 1 of 1

Peak Hour for Entire Intersection Begins at 04:30 PM

County of San Bernardino
 N/S: Lytle Creek Road/Sierra Avenue
 E/W: Lytle Creek Road
 Weather: Clear

File Name : 03_CSB_Sierra_Lytle Creek PM
 Site Code : 12218022
 Start Date : 1/24/2018
 Page No : 2

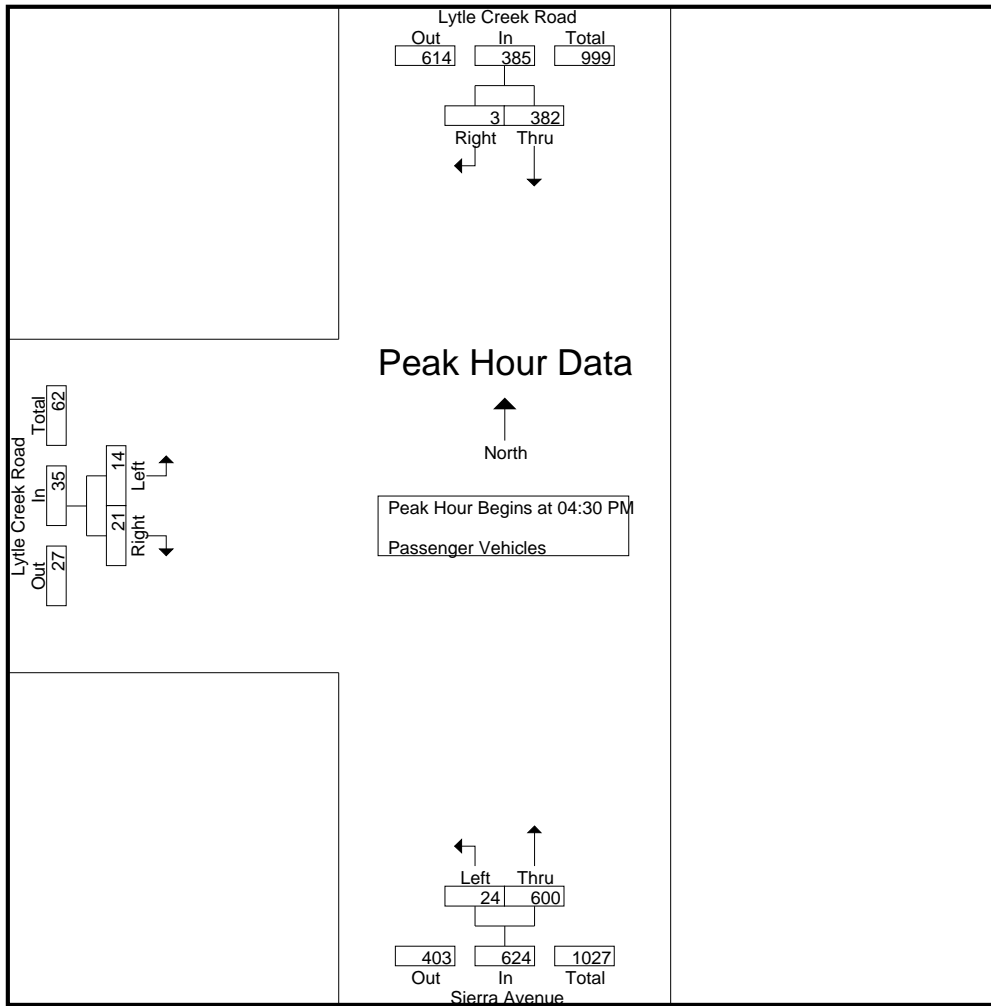

Peak Hour Analysis From 04:30 PM to 05:15 PM - Peak 1 of 1
 Peak Hour for Each Approach Begins at:

	04:30 PM			04:30 PM			04:30 PM		
+0 mins.	99	1	100	5	149	154	2	3	5
+15 mins.	94	1	95	10	143	153	4	6	10
+30 mins.	95	1	96	2	142	144	5	6	11
+45 mins.	94	0	94	7	166	173	3	6	9
Total Volume	382	3	385	24	600	624	14	21	35
% App. Total	99.2	0.8		3.8	96.2		40	60	
PHF	.965	.750	.963	.600	.904	.902	.700	.875	.795

County of San Bernardino
 N/S: Lytle Creek Road/Sierra Avenue
 E/W: Lytle Creek Road
 Weather: Clear

File Name : 03_CSB_Sierra_Lytle Creek PM
 Site Code : 12218022
 Start Date : 1/24/2018
 Page No : 1

Groups Printed- Large 2 Axle Vehicles

Start Time	Lytle Creek Road Southbound			Sierra Avenue Northbound			Lytle Creek Road Eastbound			Int. Total
	Thru	Right	App. Total	Left	Thru	App. Total	Left	Right	App. Total	
04:00 PM	1	0	1	0	0	0	0	0	0	1
04:15 PM	2	0	2	0	1	1	0	0	0	3
04:30 PM	2	0	2	0	2	2	0	1	1	5
04:45 PM	0	0	0	0	0	0	0	0	0	0
Total	5	0	5	0	3	3	0	1	1	9
05:00 PM	1	0	1	0	0	0	0	0	0	1
05:15 PM	1	0	1	0	1	1	0	0	0	2
05:30 PM	0	0	0	0	0	0	0	0	0	0
05:45 PM	1	0	1	0	1	1	0	0	0	2
Total	3	0	3	0	2	2	0	0	0	5
Grand Total	8	0	8	0	5	5	0	1	1	14
Apprch %	100	0		0	100		0	100		
Total %	57.1	0	57.1	0	35.7	35.7	0	7.1	7.1	

Start Time	Lytle Creek Road Southbound			Sierra Avenue Northbound			Lytle Creek Road Eastbound			Int. Total
	Thru	Right	App. Total	Left	Thru	App. Total	Left	Right	App. Total	
04:30 PM	2	0	2	0	2	2	0	1	1	5
04:45 PM	0	0	0	0	0	0	0	0	0	0
05:00 PM	1	0	1	0	0	0	0	0	0	1
05:15 PM	1	0	1	0	1	1	0	0	0	2
Total Volume	4	0	4	0	3	3	0	1	1	8
% App. Total	100	0		0	100		0	100		
PHF	.500	.000	.500	.000	.375	.375	.000	.250	.250	.400

Peak Hour Analysis From 04:30 PM to 05:15 PM - Peak 1 of 1
 Peak Hour for Entire Intersection Begins at 04:30 PM

County of San Bernardino
 N/S: Lytle Creek Road/Sierra Avenue
 E/W: Lytle Creek Road
 Weather: Clear

File Name : 03_CSB_Sierra_Lytle Creek PM
 Site Code : 12218022
 Start Date : 1/24/2018
 Page No : 2

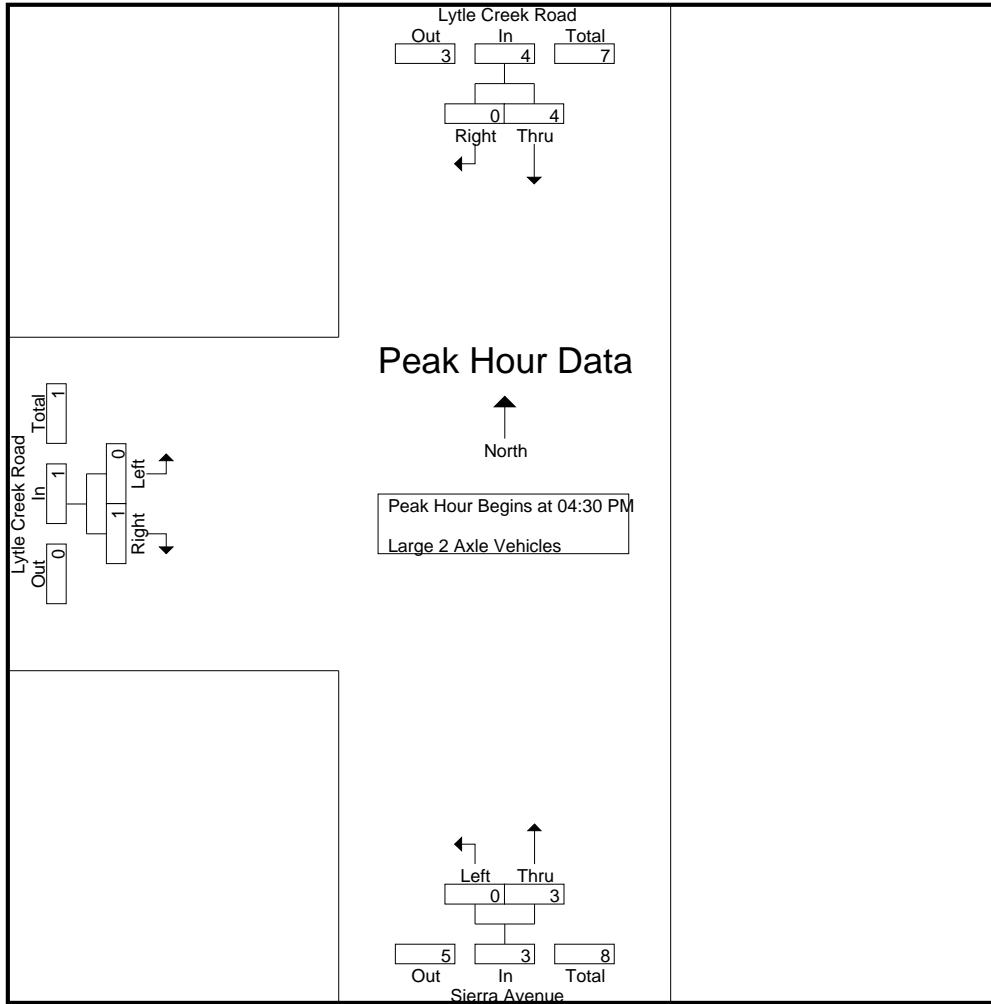

Peak Hour Analysis From 04:30 PM to 05:15 PM - Peak 1 of 1
 Peak Hour for Each Approach Begins at:

	04:30 PM			04:30 PM			04:30 PM		
+0 mins.	2	0	2	0	2	2	0	1	1
+15 mins.	0	0	0	0	0	0	0	0	0
+30 mins.	1	0	1	0	0	0	0	0	0
+45 mins.	1	0	1	0	1	1	0	0	0
Total Volume	4	0	4	0	3	3	0	1	1
% App. Total	100	0		0	100		0	100	
PHF	.500	.000	.500	.000	.375	.375	.000	.250	.250

County of San Bernardino
 N/S: Lytle Creek Road/Sierra Avenue
 E/W: Lytle Creek Road
 Weather: Clear

File Name : 03_CSB_Sierra_Lytle Creek PM
 Site Code : 12218022
 Start Date : 1/24/2018
 Page No : 1

Groups Printed- 3 Axle Vehicles

Start Time	Lytle Creek Road Southbound			Sierra Avenue Northbound			Lytle Creek Road Eastbound			Int. Total
	Thru	Right	App. Total	Left	Thru	App. Total	Left	Right	App. Total	
04:00 PM	1	0	1	0	0	0	0	0	0	1
04:15 PM	0	0	0	0	0	0	0	0	0	0
04:30 PM	0	0	0	0	0	0	0	0	0	0
04:45 PM	0	0	0	0	0	0	0	0	0	0
Total	1	0	1	0	0	0	0	0	0	1
05:00 PM	0	0	0	0	0	0	0	0	0	0
05:15 PM	0	0	0	0	0	0	0	0	0	0
05:30 PM	0	0	0	0	0	0	0	0	0	0
05:45 PM	0	0	0	0	0	0	0	0	0	0
Total	0	0	0	0	0	0	0	0	0	0
Grand Total	1	0	1	0	0	0	0	0	0	1
Apprch %	100	0		0	0		0	0		
Total %	100	0	100	0	0	0	0	0	0	

Start Time	Lytle Creek Road Southbound			Sierra Avenue Northbound			Lytle Creek Road Eastbound			Int. Total
	Thru	Right	App. Total	Left	Thru	App. Total	Left	Right	App. Total	
04:30 PM	0	0	0	0	0	0	0	0	0	0
04:45 PM	0	0	0	0	0	0	0	0	0	0
05:00 PM	0	0	0	0	0	0	0	0	0	0
05:15 PM	0	0	0	0	0	0	0	0	0	0
Total Volume	0	0	0	0	0	0	0	0	0	0
% App. Total	0	0		0	0		0	0		
PHF	.000	.000	.000	.000	.000	.000	.000	.000	.000	.000

Peak Hour Analysis From 04:30 PM to 05:15 PM - Peak 1 of 1
 Peak Hour for Entire Intersection Begins at 04:30 PM

County of San Bernardino
 N/S: Lytle Creek Road/Sierra Avenue
 E/W: Lytle Creek Road
 Weather: Clear

File Name : 03_CSB_Sierra_Lytle Creek PM
 Site Code : 12218022
 Start Date : 1/24/2018
 Page No : 1

Groups Printed- 4+ Axle Trucks

Start Time	Lytle Creek Road Southbound			Sierra Avenue Northbound			Lytle Creek Road Eastbound			Int. Total
	Thru	Right	App. Total	Left	Thru	App. Total	Left	Right	App. Total	
04:00 PM	0	0	0	0	0	0	0	0	0	0
04:15 PM	0	0	0	0	1	1	0	0	0	1
04:30 PM	1	0	1	0	0	0	0	0	0	1
04:45 PM	0	0	0	0	0	0	0	0	0	0
Total	1	0	1	0	1	1	0	0	0	2
05:00 PM	2	0	2	0	1	1	0	0	0	3
05:15 PM	2	0	2	0	0	0	0	0	0	2
05:30 PM	1	0	1	0	1	1	0	0	0	2
05:45 PM	0	0	0	0	2	2	0	0	0	2
Total	5	0	5	0	4	4	0	0	0	9
Grand Total	6	0	6	0	5	5	0	0	0	11
Apprch %	100	0		0	100		0	0		
Total %	54.5	0	54.5	0	45.5	45.5	0	0	0	

Start Time	Lytle Creek Road Southbound			Sierra Avenue Northbound			Lytle Creek Road Eastbound			Int. Total
	Thru	Right	App. Total	Left	Thru	App. Total	Left	Right	App. Total	
04:30 PM	1	0	1	0	0	0	0	0	0	1
04:45 PM	0	0	0	0	0	0	0	0	0	0
05:00 PM	2	0	2	0	1	1	0	0	0	3
05:15 PM	2	0	2	0	0	0	0	0	0	2
Total Volume	5	0	5	0	1	1	0	0	0	6
% App. Total	100	0		0	100		0	0		
PHF	.625	.000	.625	.000	.250	.250	.000	.000	.000	.500

Peak Hour Analysis From 04:30 PM to 05:15 PM - Peak 1 of 1

Peak Hour for Entire Intersection Begins at 04:30 PM

County of San Bernardino
 N/S: Lytle Creek Road/Sierra Avenue
 E/W: Lytle Creek Road
 Weather: Clear

File Name : 03_CSB_Sierra_Lytle Creek PM
 Site Code : 12218022
 Start Date : 1/24/2018
 Page No : 2

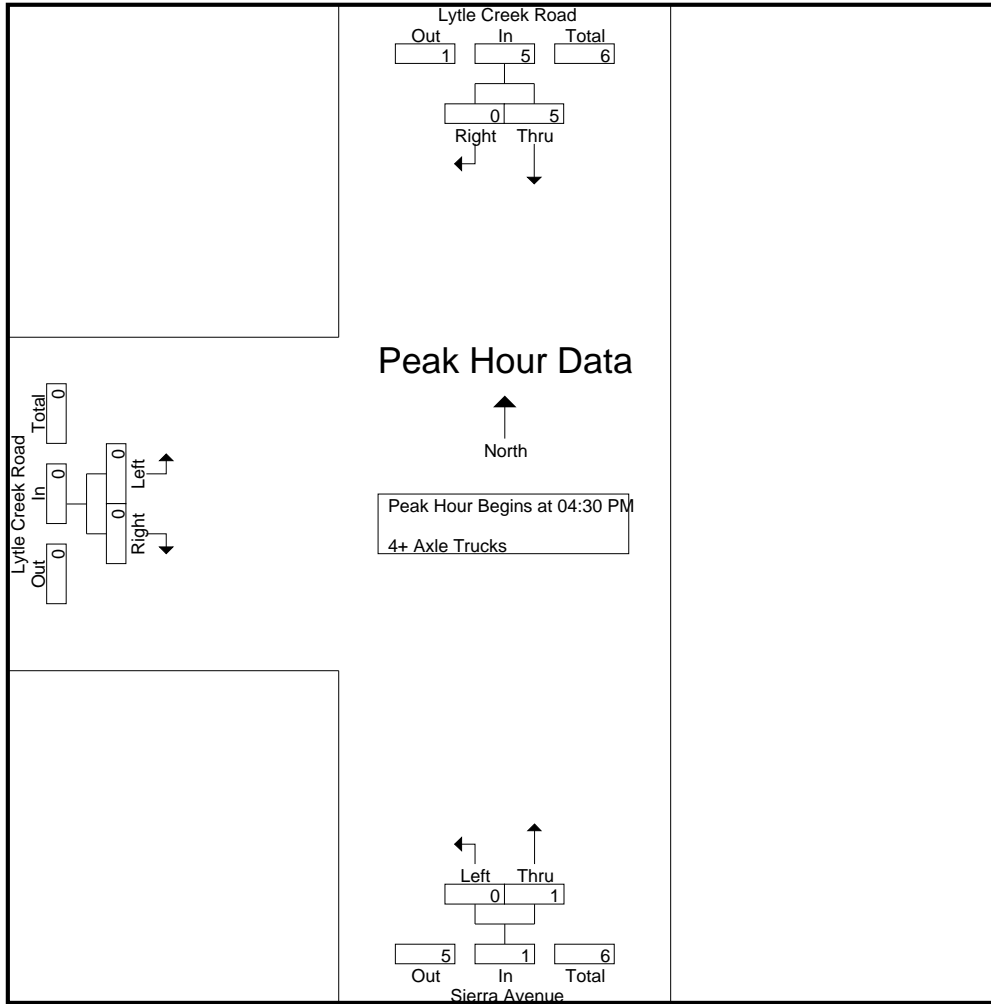

Peak Hour Analysis From 04:30 PM to 05:15 PM - Peak 1 of 1
 Peak Hour for Each Approach Begins at:

	04:30 PM			04:30 PM			04:30 PM		
+0 mins.	1	0	1	0	0	0	0	0	0
+15 mins.	0	0	0	0	0	0	0	0	0
+30 mins.	2	0	2	0	1	1	0	0	0
+45 mins.	2	0	2	0	0	0	0	0	0
Total Volume	5	0	5	0	1	1	0	0	0
% App. Total	100	0		0	100		0	0	
PHF	.625	.000	.625	.000	.250	.250	.000	.000	.000

City of Fontana
 N/S: Sierra Avenue
 E/W: I-15 Southbound Ramps
 Weather: Clear

File Name : 04_FON_Sierra_15S AM
 Site Code : 12218022
 Start Date : 1/24/2018
 Page No : 1

Groups Printed- Passenger Vehicles - Large 2 Axle Vehicles - 3 Axle Vehicles - 4+ Axle Trucks

Start Time	Sierra Avenue Southbound				I-15 Southbound Off Ramp Westbound				Sierra Avenue Northbound				I-15 Southbound On Ramp Eastbound				Int. Total
	Left	Thru	Right	App. Total	Left	Thru	Right	App. Total	Left	Thru	Right	App. Total	Left	Thru	Right	App. Total	
07:00 AM	0	74	193	267	96	0	33	129	104	83	0	187	0	0	0	0	583
07:15 AM	0	85	206	291	119	0	33	152	113	113	0	226	0	0	0	0	669
07:30 AM	0	108	198	306	124	0	31	155	98	89	0	187	0	0	0	0	648
07:45 AM	0	66	119	185	99	0	33	132	67	90	0	157	0	0	0	0	474
Total	0	333	716	1049	438	0	130	568	382	375	0	757	0	0	0	0	2374
08:00 AM	0	64	116	180	99	0	36	135	70	85	0	155	0	0	0	0	470
08:15 AM	0	71	102	173	92	0	33	125	49	89	0	138	0	0	0	0	436
08:30 AM	0	54	118	172	95	0	38	133	41	69	0	110	0	0	0	0	415
08:45 AM	0	60	97	157	84	0	37	121	30	71	0	101	0	0	0	0	379
Total	0	249	433	682	370	0	144	514	190	314	0	504	0	0	0	0	1700
Grand Total	0	582	1149	1731	808	0	274	1082	572	689	0	1261	0	0	0	0	4074
Apprch %	0	33.6	66.4		74.7	0	25.3		45.4	54.6	0		0	0	0		
Total %	0	14.3	28.2	42.5	19.8	0	6.7	26.6	14	16.9	0	31	0	0	0	0	
Passenger Vehicles	0	555	1123	1678	779	0	255	1034	550	660	0	1210	0	0	0	0	3922
% Passenger Vehicles	0	95.4	97.7	96.9	96.4	0	93.1	95.6	96.2	95.8	0	96	0	0	0	0	96.3
Large 2 Axle Vehicles	0	13	9	22	10	0	10	20	10	10	0	20	0	0	0	0	62
% Large 2 Axle Vehicles	0	2.2	0.8	1.3	1.2	0	3.6	1.8	1.7	1.5	0	1.6	0	0	0	0	1.5
3 Axle Vehicles	0	6	4	10	1	0	1	2	1	9	0	10	0	0	0	0	22
% 3 Axle Vehicles	0	1	0.3	0.6	0.1	0	0.4	0.2	0.2	1.3	0	0.8	0	0	0	0	0.5
4+ Axle Trucks	0	8	13	21	18	0	8	26	11	10	0	21	0	0	0	0	68
% 4+ Axle Trucks	0	1.4	1.1	1.2	2.2	0	2.9	2.4	1.9	1.5	0	1.7	0	0	0	0	1.7

Start Time	Sierra Avenue Southbound				I-15 Southbound Off Ramp Westbound				Sierra Avenue Northbound				I-15 Southbound On Ramp Eastbound				Int. Total
	Left	Thru	Right	App. Total	Left	Thru	Right	App. Total	Left	Thru	Right	App. Total	Left	Thru	Right	App. Total	
Peak Hour Analysis From 07:00 AM to 08:45 AM - Peak 1 of 1																	
Peak Hour for Entire Intersection Begins at 07:00 AM																	
07:00 AM	0	74	193	267	96	0	33	129	104	83	0	187	0	0	0	0	583
07:15 AM	0	85	206	291	119	0	33	152	113	113	0	226	0	0	0	0	669
07:30 AM	0	108	198	306	124	0	31	155	98	89	0	187	0	0	0	0	648
07:45 AM	0	66	119	185	99	0	33	132	67	90	0	157	0	0	0	0	474
Total Volume	0	333	716	1049	438	0	130	568	382	375	0	757	0	0	0	0	2374
% App. Total	0	31.7	68.3		77.1	0	22.9		50.5	49.5	0		0	0	0		
PHF	.000	.771	.869	.857	.883	.000	.985	.916	.845	.830	.000	.837	.000	.000	.000	.000	.887

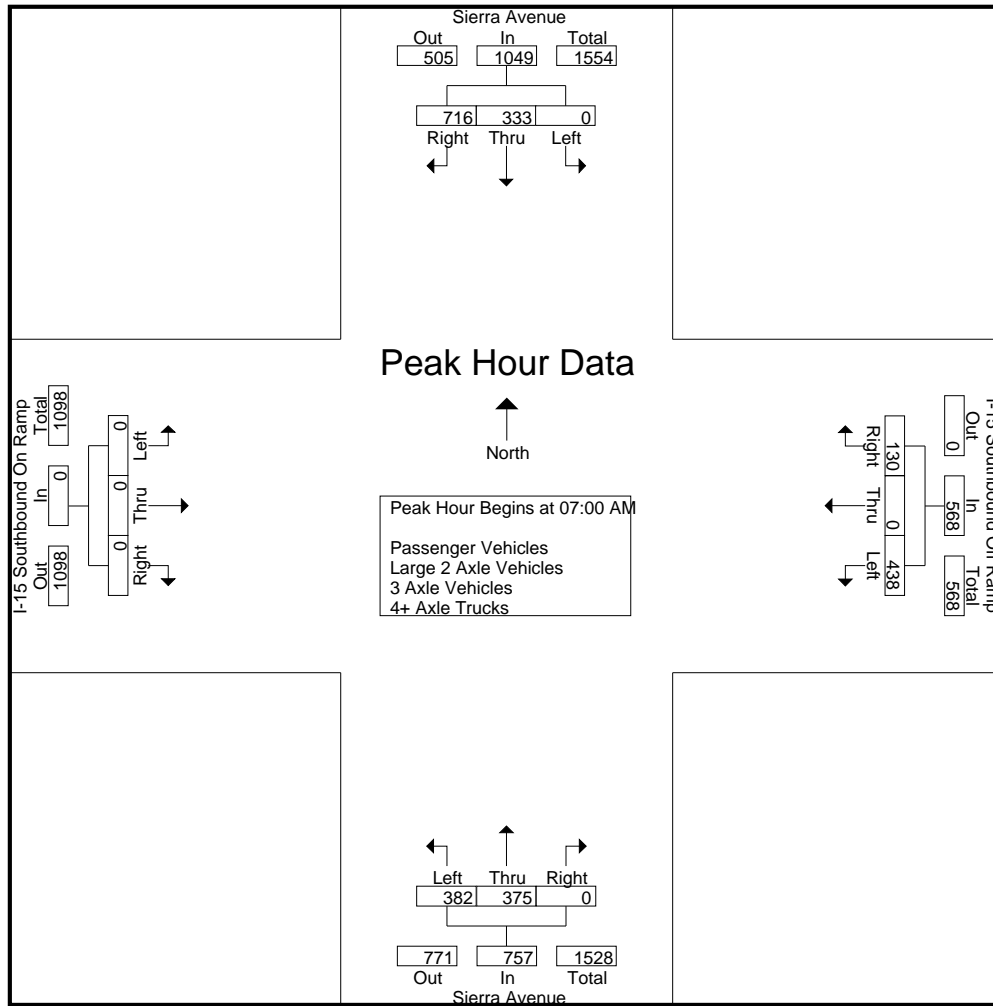

Peak Hour Analysis From 07:00 AM to 08:45 AM - Peak 1 of 1
 Peak Hour for Each Approach Begins at:

	07:00 AM				07:15 AM				07:00 AM				07:00 AM			
+0 mins.	0	74	193	267	119	0	33	152	104	83	0	187	0	0	0	0
+15 mins.	0	85	206	291	124	0	31	155	113	113	0	226	0	0	0	0
+30 mins.	0	108	198	306	99	0	33	132	98	89	0	187	0	0	0	0
+45 mins.	0	66	119	185	99	0	36	135	67	90	0	157	0	0	0	0
Total Volume	0	333	716	1049	441	0	133	574	382	375	0	757	0	0	0	0
% App. Total	0	31.7	68.3		76.8	0	23.2		50.5	49.5	0		0	0	0	
PHF	.000	.771	.869	.857	.889	.000	.924	.926	.845	.830	.000	.837	.000	.000	.000	.000

City of Fontana
 N/S: Sierra Avenue
 E/W: I-15 Southbound Ramps
 Weather: Clear

File Name : 04_FON_Sierra_15S AM
 Site Code : 12218022
 Start Date : 1/24/2018
 Page No : 1

Groups Printed- Passenger Vehicles

Start Time	Sierra Avenue Southbound				I-15 Southbound Off Ramp Westbound				Sierra Avenue Northbound				I-15 Southbound On Ramp Eastbound				Int. Total
	Left	Thru	Right	App. Total	Left	Thru	Right	App. Total	Left	Thru	Right	App. Total	Left	Thru	Right	App. Total	
07:00 AM	0	71	191	262	94	0	33	127	103	81	0	184	0	0	0	0	573
07:15 AM	0	82	202	284	117	0	31	148	112	109	0	221	0	0	0	0	653
07:30 AM	0	104	195	299	122	0	28	150	92	85	0	177	0	0	0	0	626
07:45 AM	0	59	112	171	93	0	31	124	62	85	0	147	0	0	0	0	442
Total	0	316	700	1016	426	0	123	549	369	360	0	729	0	0	0	0	2294
08:00 AM	0	61	111	172	93	0	34	127	67	83	0	150	0	0	0	0	449
08:15 AM	0	68	100	168	89	0	30	119	47	86	0	133	0	0	0	0	420
08:30 AM	0	53	116	169	90	0	34	124	40	65	0	105	0	0	0	0	398
08:45 AM	0	57	96	153	81	0	34	115	27	66	0	93	0	0	0	0	361
Total	0	239	423	662	353	0	132	485	181	300	0	481	0	0	0	0	1628
Grand Total	0	555	1123	1678	779	0	255	1034	550	660	0	1210	0	0	0	0	3922
Apprch %	0	33.1	66.9		75.3	0	24.7		45.5	54.5	0		0	0	0		
Total %	0	14.2	28.6	42.8	19.9	0	6.5	26.4	14	16.8	0	30.9	0	0	0	0	

Start Time	Sierra Avenue Southbound				I-15 Southbound Off Ramp Westbound				Sierra Avenue Northbound				I-15 Southbound On Ramp Eastbound				Int. Total
	Left	Thru	Right	App. Total	Left	Thru	Right	App. Total	Left	Thru	Right	App. Total	Left	Thru	Right	App. Total	
Peak Hour Analysis From 07:00 AM to 07:45 AM - Peak 1 of 1																	
Peak Hour for Entire Intersection Begins at 07:00 AM																	
07:00 AM	0	71	191	262	94	0	33	127	103	81	0	184	0	0	0	0	573
07:15 AM	0	82	202	284	117	0	31	148	112	109	0	221	0	0	0	0	653
07:30 AM	0	104	195	299	122	0	28	150	92	85	0	177	0	0	0	0	626
07:45 AM	0	59	112	171	93	0	31	124	62	85	0	147	0	0	0	0	442
Total Volume	0	316	700	1016	426	0	123	549	369	360	0	729	0	0	0	0	2294
% App. Total	0	31.1	68.9		77.6	0	22.4		50.6	49.4	0		0	0	0		
PHF	.000	.760	.866	.849	.873	.000	.932	.915	.824	.826	.000	.825	.000	.000	.000	.000	.878

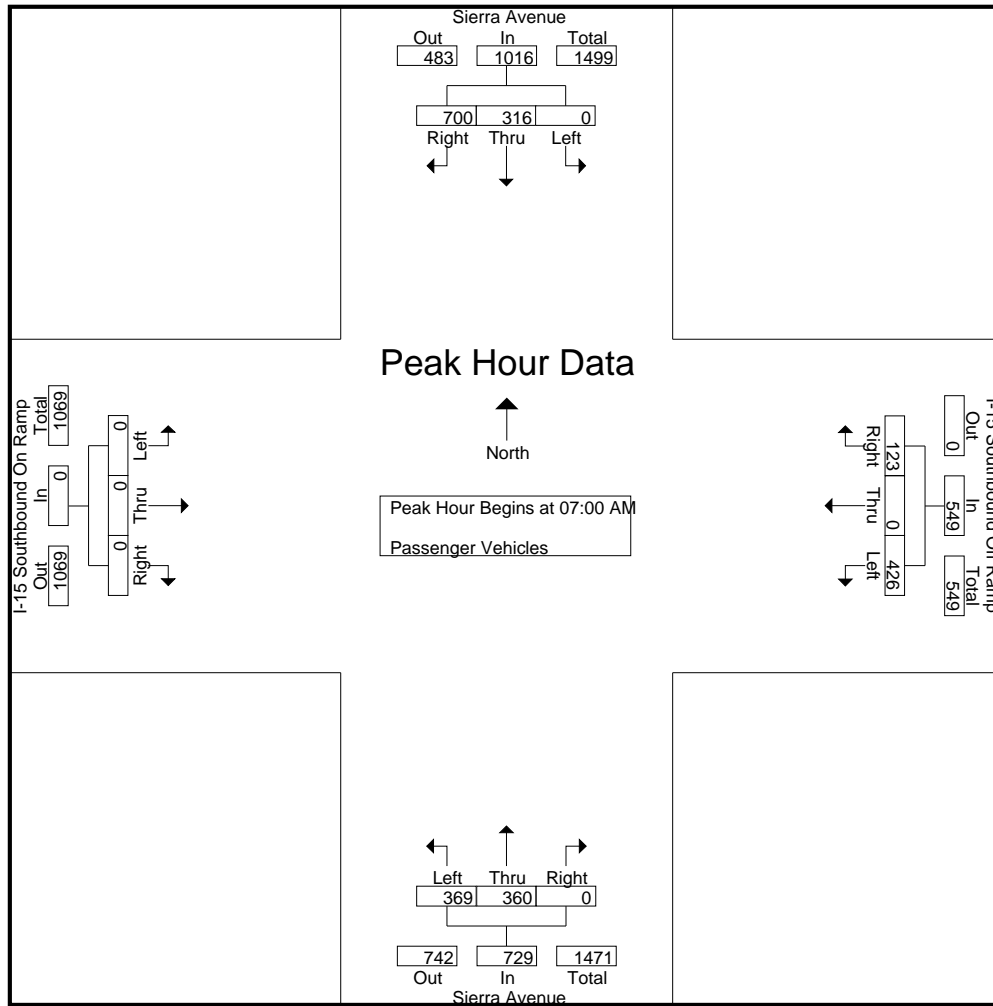

Peak Hour Analysis From 07:00 AM to 07:45 AM - Peak 1 of 1
 Peak Hour for Each Approach Begins at:

	07:00 AM				07:00 AM				07:00 AM				07:00 AM			
+0 mins.	0	71	191	262	94	0	33	127	103	81	0	184	0	0	0	0
+15 mins.	0	82	202	284	117	0	31	148	112	109	0	221	0	0	0	0
+30 mins.	0	104	195	299	122	0	28	150	92	85	0	177	0	0	0	0
+45 mins.	0	59	112	171	93	0	31	124	62	85	0	147	0	0	0	0
Total Volume	0	316	700	1016	426	0	123	549	369	360	0	729	0	0	0	0
% App. Total	0	31.1	68.9		77.6	0	22.4		50.6	49.4	0		0	0	0	
PHF	.000	.760	.866	.849	.873	.000	.932	.915	.824	.826	.000	.825	.000	.000	.000	.000

City of Fontana
 N/S: Sierra Avenue
 E/W: I-15 Southbound Ramps
 Weather: Clear

File Name : 04_FON_Sierra_15S AM
 Site Code : 12218022
 Start Date : 1/24/2018
 Page No : 1

Groups Printed- Large 2 Axle Vehicles

Start Time	Sierra Avenue Southbound				I-15 Southbound Off Ramp Westbound				Sierra Avenue Northbound				I-15 Southbound On Ramp Eastbound				Int. Total
	Left	Thru	Right	App. Total	Left	Thru	Right	App. Total	Left	Thru	Right	App. Total	Left	Thru	Right	App. Total	
07:00 AM	0	3	1	4	0	0	0	0	1	0	0	1	0	0	0	0	5
07:15 AM	0	3	1	4	1	0	1	2	1	4	0	5	0	0	0	0	11
07:30 AM	0	3	0	3	1	0	2	3	3	1	0	4	0	0	0	0	10
07:45 AM	0	2	1	3	3	0	1	4	0	1	0	1	0	0	0	0	8
Total	0	11	3	14	5	0	4	9	5	6	0	11	0	0	0	0	34
08:00 AM	0	2	2	4	2	0	0	2	1	0	0	1	0	0	0	0	7
08:15 AM	0	0	1	1	1	0	2	3	2	0	0	2	0	0	0	0	6
08:30 AM	0	0	2	2	1	0	3	4	1	0	0	1	0	0	0	0	7
08:45 AM	0	0	1	1	1	0	1	2	1	4	0	5	0	0	0	0	8
Total	0	2	6	8	5	0	6	11	5	4	0	9	0	0	0	0	28
Grand Total	0	13	9	22	10	0	10	20	10	10	0	20	0	0	0	0	62
Apprch %	0	59.1	40.9		50	0	50		50	50	0		0	0	0		
Total %	0	21	14.5	35.5	16.1	0	16.1	32.3	16.1	16.1	0	32.3	0	0	0	0	

Start Time	Sierra Avenue Southbound				I-15 Southbound Off Ramp Westbound				Sierra Avenue Northbound				I-15 Southbound On Ramp Eastbound				Int. Total
	Left	Thru	Right	App. Total	Left	Thru	Right	App. Total	Left	Thru	Right	App. Total	Left	Thru	Right	App. Total	
Peak Hour Analysis From 07:00 AM to 07:45 AM - Peak 1 of 1																	
Peak Hour for Entire Intersection Begins at 07:00 AM																	
07:00 AM	0	3	1	4	0	0	0	0	1	0	0	1	0	0	0	0	5
07:15 AM	0	3	1	4	1	0	1	2	1	4	0	5	0	0	0	0	11
07:30 AM	0	3	0	3	1	0	2	3	3	1	0	4	0	0	0	0	10
07:45 AM	0	2	1	3	3	0	1	4	0	1	0	1	0	0	0	0	8
Total Volume	0	11	3	14	5	0	4	9	5	6	0	11	0	0	0	0	34
% App. Total	0	78.6	21.4		55.6	0	44.4		45.5	54.5	0		0	0	0		
PHF	.000	.917	.750	.875	.417	.000	.500	.563	.417	.375	.000	.550	.000	.000	.000	.000	.773

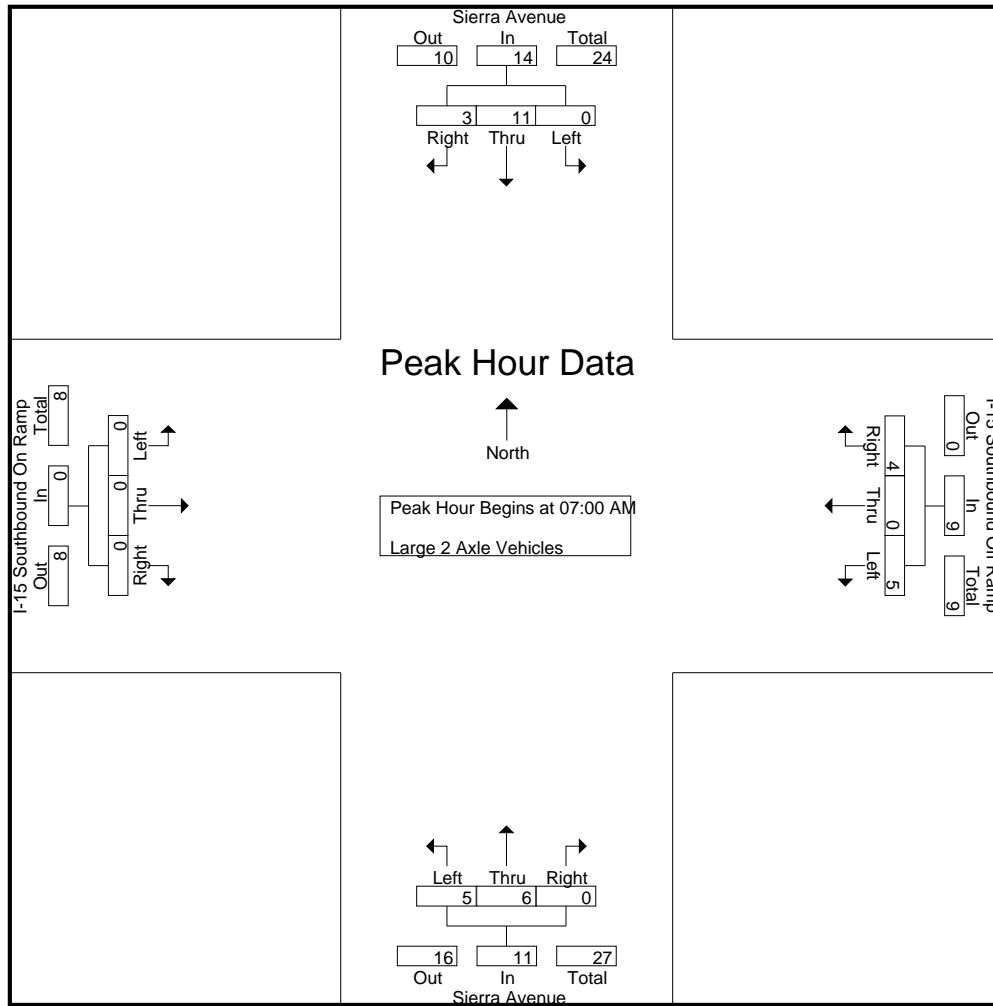

Peak Hour Analysis From 07:00 AM to 07:45 AM - Peak 1 of 1
 Peak Hour for Each Approach Begins at:

	07:00 AM				07:00 AM				07:00 AM				07:00 AM			
+0 mins.	0	3	1	4	0	0	0	0	1	0	0	1	0	0	0	0
+15 mins.	0	3	1	4	1	0	1	2	1	4	0	5	0	0	0	0
+30 mins.	0	3	0	3	1	0	2	3	3	1	0	4	0	0	0	0
+45 mins.	0	2	1	3	3	0	1	4	0	1	0	1	0	0	0	0
Total Volume	0	11	3	14	5	0	4	9	5	6	0	11	0	0	0	0
% App. Total	0	78.6	21.4		55.6	0	44.4		45.5	54.5	0		0	0	0	
PHF	.000	.917	.750	.875	.417	.000	.500	.563	.417	.375	.000	.550	.000	.000	.000	.000

City of Fontana
 N/S: Sierra Avenue
 E/W: I-15 Southbound Ramps
 Weather: Clear

File Name : 04_FON_Sierra_15S AM
 Site Code : 12218022
 Start Date : 1/24/2018
 Page No : 1

Groups Printed- 3 Axle Vehicles

Start Time	Sierra Avenue Southbound				I-15 Southbound Off Ramp Westbound				Sierra Avenue Northbound				I-15 Southbound On Ramp Eastbound				Int. Total	
	Left	Thru	Right	App. Total	Left	Thru	Right	App. Total	Left	Thru	Right	App. Total	Left	Thru	Right	App. Total		
07:00 AM	0	0	0	0	0	0	0	0	0	0	1	0	1	0	0	0	0	1
07:15 AM	0	0	1	1	0	0	0	0	0	0	0	0	0	0	0	0	0	1
07:30 AM	0	0	1	1	0	0	0	0	0	1	2	0	3	0	0	0	0	4
07:45 AM	0	2	1	3	0	0	0	0	0	0	3	0	3	0	0	0	0	6
Total	0	2	3	5	0	0	0	0	0	1	6	0	7	0	0	0	0	12
08:00 AM	0	0	1	1	0	0	0	0	0	0	1	0	1	0	0	0	0	2
08:15 AM	0	2	0	2	1	0	1	2	0	1	0	1	1	0	0	0	0	5
08:30 AM	0	1	0	1	0	0	0	0	0	0	1	0	1	0	0	0	0	2
08:45 AM	0	1	0	1	0	0	0	0	0	0	0	0	0	0	0	0	0	1
Total	0	4	1	5	1	0	1	2	0	3	0	3	0	0	0	0	0	10
Grand Total	0	6	4	10	1	0	1	2	1	9	0	10	0	0	0	0	0	22
Apprch %	0	60	40		50	0	50		10	90	0		0	0	0			
Total %	0	27.3	18.2	45.5	4.5	0	4.5	9.1	4.5	40.9	0	45.5	0	0	0	0	0	

Start Time	Sierra Avenue Southbound				I-15 Southbound Off Ramp Westbound				Sierra Avenue Northbound				I-15 Southbound On Ramp Eastbound				Int. Total	
	Left	Thru	Right	App. Total	Left	Thru	Right	App. Total	Left	Thru	Right	App. Total	Left	Thru	Right	App. Total		
Peak Hour Analysis From 07:00 AM to 07:45 AM - Peak 1 of 1																		
Peak Hour for Entire Intersection Begins at 07:00 AM																		
07:00 AM	0	0	0	0	0	0	0	0	0	0	1	0	1	0	0	0	0	1
07:15 AM	0	0	1	1	0	0	0	0	0	0	0	0	0	0	0	0	0	1
07:30 AM	0	0	1	1	0	0	0	0	0	1	2	0	3	0	0	0	0	4
07:45 AM	0	2	1	3	0	0	0	0	0	0	3	0	3	0	0	0	0	6
Total Volume	0	2	3	5	0	0	0	0	0	1	6	0	7	0	0	0	0	12
% App. Total	0	40	60		0	0	0			14.3	85.7	0		0	0	0		
PHF	.000	.250	.750	.417	.000	.000	.000	.000	.000	.250	.500	.000	.583	.000	.000	.000	.000	.500

City of Fontana
 N/S: Sierra Avenue
 E/W: I-15 Southbound Ramps
 Weather: Clear

File Name : 04_FON_Sierra_15S AM
 Site Code : 12218022
 Start Date : 1/24/2018
 Page No : 2

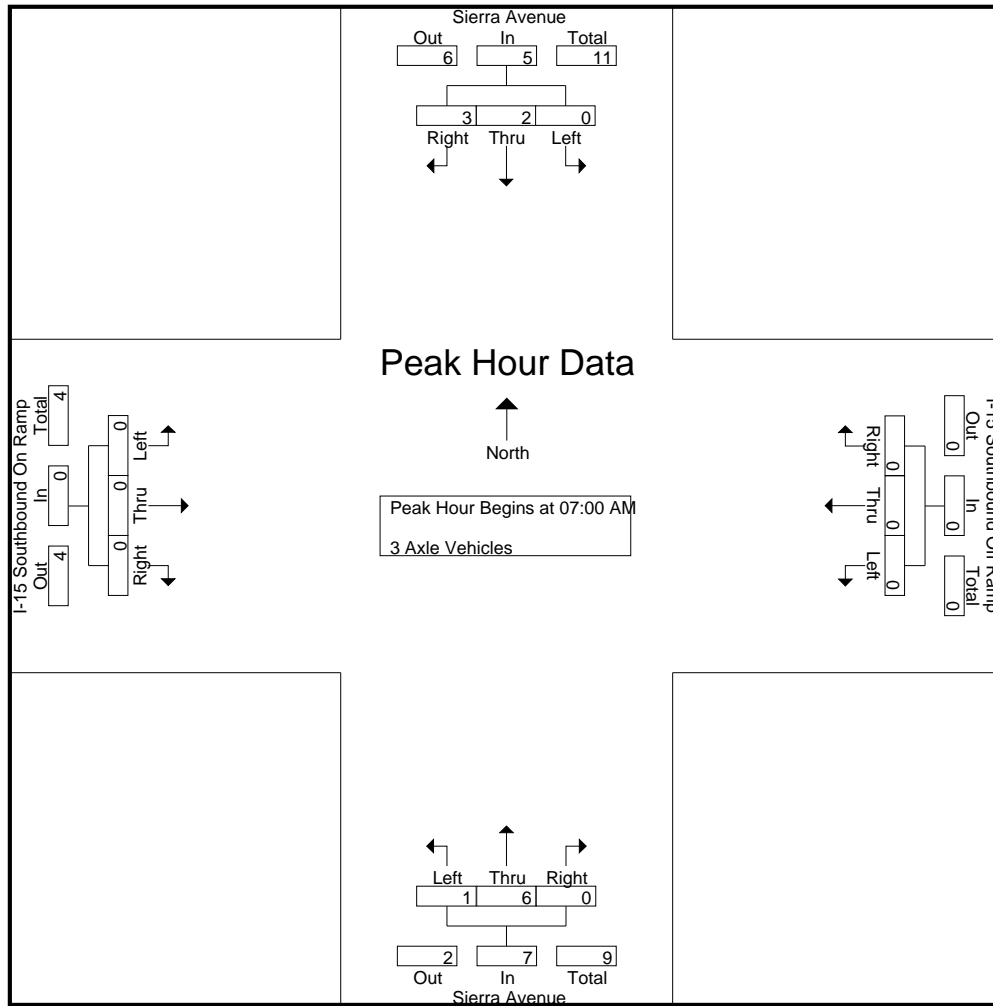

Peak Hour Analysis From 07:00 AM to 07:45 AM - Peak 1 of 1
 Peak Hour for Each Approach Begins at:

	07:00 AM				07:00 AM				07:00 AM				07:00 AM			
+0 mins.	0	0	0	0	0	0	0	0	0	1	0	1	0	0	0	0
+15 mins.	0	0	1	1	0	0	0	0	0	0	0	0	0	0	0	0
+30 mins.	0	0	1	1	0	0	0	0	1	2	0	3	0	0	0	0
+45 mins.	0	2	1	3	0	0	0	0	0	3	0	3	0	0	0	0
Total Volume	0	2	3	5	0	0	0	0	1	6	0	7	0	0	0	0
% App. Total	0	40	60		0	0	0		14.3	85.7	0		0	0	0	
PHF	.000	.250	.750	.417	.000	.000	.000	.000	.250	.500	.000	.583	.000	.000	.000	.000

City of Fontana
 N/S: Sierra Avenue
 E/W: I-15 Southbound Ramps
 Weather: Clear

File Name : 04_FON_Sierra_15S AM
 Site Code : 12218022
 Start Date : 1/24/2018
 Page No : 1

Groups Printed- 4+ Axle Trucks

Start Time	Sierra Avenue Southbound				I-15 Southbound Off Ramp Westbound				Sierra Avenue Northbound				I-15 Southbound On Ramp Eastbound				Int. Total
	Left	Thru	Right	App. Total	Left	Thru	Right	App. Total	Left	Thru	Right	App. Total	Left	Thru	Right	App. Total	
07:00 AM	0	0	1	1	2	0	0	2	0	1	0	1	0	0	0	0	4
07:15 AM	0	0	2	2	1	0	1	2	0	0	0	0	0	0	0	0	4
07:30 AM	0	1	2	3	1	0	1	2	2	1	0	3	0	0	0	0	8
07:45 AM	0	3	5	8	3	0	1	4	5	1	0	6	0	0	0	0	18
Total	0	4	10	14	7	0	3	10	7	3	0	10	0	0	0	0	34
08:00 AM	0	1	2	3	4	0	2	6	2	1	0	3	0	0	0	0	12
08:15 AM	0	1	1	2	1	0	0	1	0	2	0	2	0	0	0	0	5
08:30 AM	0	0	0	0	4	0	1	5	0	3	0	3	0	0	0	0	8
08:45 AM	0	2	0	2	2	0	2	4	2	1	0	3	0	0	0	0	9
Total	0	4	3	7	11	0	5	16	4	7	0	11	0	0	0	0	34
Grand Total	0	8	13	21	18	0	8	26	11	10	0	21	0	0	0	0	68
Apprch %	0	38.1	61.9		69.2	0	30.8		52.4	47.6	0		0	0	0		
Total %	0	11.8	19.1	30.9	26.5	0	11.8	38.2	16.2	14.7	0	30.9	0	0	0	0	

Start Time	Sierra Avenue Southbound				I-15 Southbound Off Ramp Westbound				Sierra Avenue Northbound				I-15 Southbound On Ramp Eastbound				Int. Total
	Left	Thru	Right	App. Total	Left	Thru	Right	App. Total	Left	Thru	Right	App. Total	Left	Thru	Right	App. Total	
07:00 AM	0	0	1	1	2	0	0	2	0	1	0	1	0	0	0	0	4
07:15 AM	0	0	2	2	1	0	1	2	0	0	0	0	0	0	0	0	4
07:30 AM	0	1	2	3	1	0	1	2	2	1	0	3	0	0	0	0	8
07:45 AM	0	3	5	8	3	0	1	4	5	1	0	6	0	0	0	0	18
Total Volume	0	4	10	14	7	0	3	10	7	3	0	10	0	0	0	0	34
% App. Total	0	28.6	71.4		70	0	30		70	30	0		0	0	0		
PHF	.000	.333	.500	.438	.583	.000	.750	.625	.350	.750	.000	.417	.000	.000	.000	.000	.472

Peak Hour Analysis From 07:00 AM to 07:45 AM - Peak 1 of 1

Peak Hour for Entire Intersection Begins at 07:00 AM

City of Fontana
 N/S: Sierra Avenue
 E/W: I-15 Southbound Ramps
 Weather: Clear

File Name : 04_FON_Sierra_15S AM
 Site Code : 12218022
 Start Date : 1/24/2018
 Page No : 2

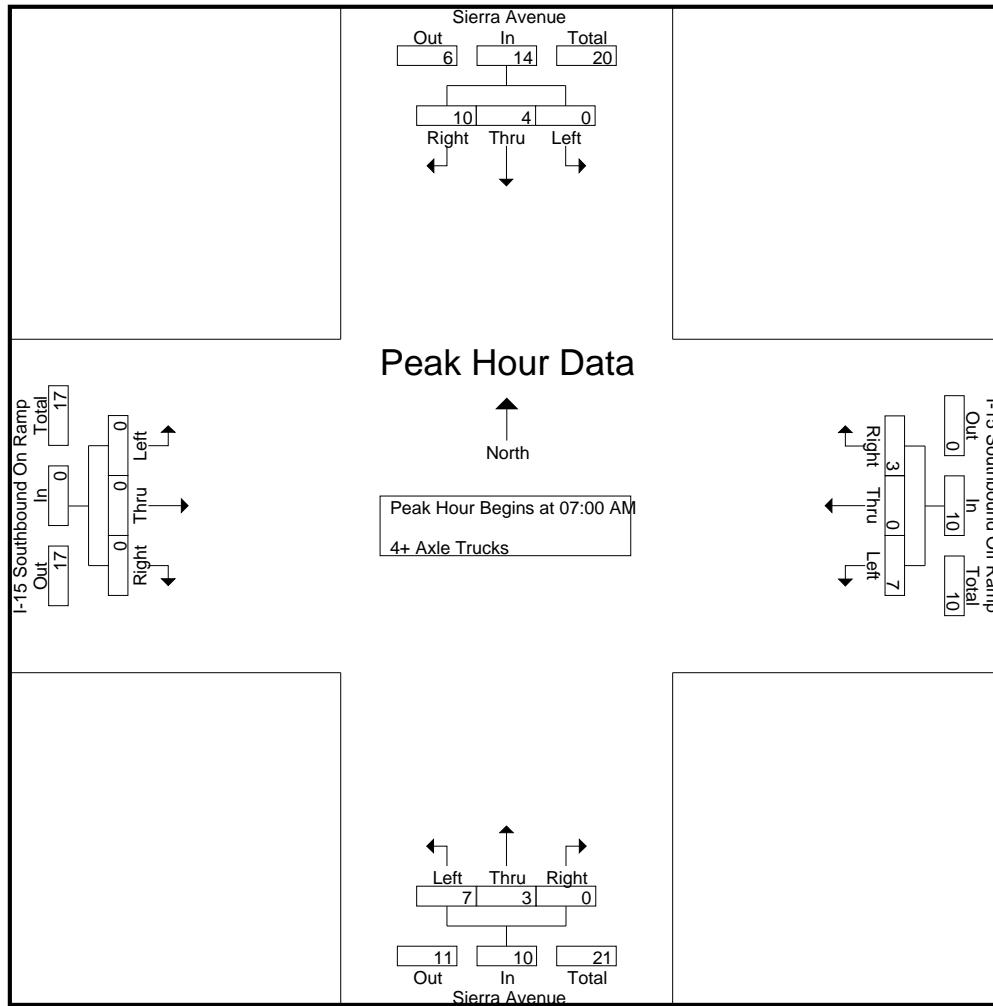

Peak Hour Analysis From 07:00 AM to 07:45 AM - Peak 1 of 1
 Peak Hour for Each Approach Begins at:

	07:00 AM				07:00 AM				07:00 AM				07:00 AM			
+0 mins.	0	0	1	1	2	0	0	2	0	1	0	1	0	0	0	0
+15 mins.	0	0	2	2	1	0	1	2	0	0	0	0	0	0	0	0
+30 mins.	0	1	2	3	1	0	1	2	2	1	0	3	0	0	0	0
+45 mins.	0	3	5	8	3	0	1	4	5	1	0	6	0	0	0	0
Total Volume	0	4	10	14	7	0	3	10	7	3	0	10	0	0	0	0
% App. Total	0	28.6	71.4		70	0	30		70	30	0		0	0	0	
PHF	.000	.333	.500	.438	.583	.000	.750	.625	.350	.750	.000	.417	.000	.000	.000	.000

City of Fontana
 N/S: Sierra Avenue
 E/W: I-15 Southbound Ramps
 Weather: Clear

File Name : 04_FON_Sierra_15S PM
 Site Code : 12218022
 Start Date : 1/24/2018
 Page No : 1

Groups Printed- Passenger Vehicles - Large 2 Axle Vehicles - 3 Axle Vehicles - 4+ Axle Trucks

Start Time	Sierra Avenue Southbound				I-15 Southbound Off Ramp Westbound				Sierra Avenue Northbound				I-15 Southbound On Ramp Eastbound				Int. Total
	Left	Thru	Right	App. Total	Left	Thru	Right	App. Total	Left	Thru	Right	App. Total	Left	Thru	Right	App. Total	
04:00 PM	0	104	52	156	94	1	25	120	29	164	0	193	0	0	0	0	469
04:15 PM	0	83	81	164	76	1	24	101	35	167	0	202	0	0	0	0	467
04:30 PM	0	77	70	147	46	1	18	65	47	213	0	260	0	0	0	0	472
04:45 PM	0	87	89	176	72	1	22	95	42	211	0	253	0	0	0	0	524
Total	0	351	292	643	288	4	89	381	153	755	0	908	0	0	0	0	1932
05:00 PM	0	91	63	154	58	0	19	77	46	186	0	232	0	0	0	0	463
05:15 PM	0	91	69	160	73	1	24	98	35	200	0	235	0	0	0	0	493
05:30 PM	0	91	71	162	56	1	25	82	37	193	0	230	0	0	0	0	474
05:45 PM	0	73	70	143	61	0	12	73	30	200	0	230	0	0	0	0	446
Total	0	346	273	619	248	2	80	330	148	779	0	927	0	0	0	0	1876
Grand Total	0	697	565	1262	536	6	169	711	301	1534	0	1835	0	0	0	0	3808
Apprch %	0	55.2	44.8		75.4	0.8	23.8		16.4	83.6	0		0	0	0		
Total %	0	18.3	14.8	33.1	14.1	0.2	4.4	18.7	7.9	40.3	0	48.2	0	0	0	0	
Passenger Vehicles	0	682	545	1227	511	4	161	676	294	1508	0	1802	0	0	0	0	3705
% Passenger Vehicles	0	97.8	96.5	97.2	95.3	66.7	95.3	95.1	97.7	98.3	0	98.2	0	0	0	0	97.3
Large 2 Axle Vehicles	0	8	12	20	5	1	5	11	4	12	0	16	0	0	0	0	47
% Large 2 Axle Vehicles	0	1.1	2.1	1.6	0.9	16.7	3	1.5	1.3	0.8	0	0.9	0	0	0	0	1.2
3 Axle Vehicles	0	0	0	0	1	0	0	1	0	0	0	0	0	0	0	0	1
% 3 Axle Vehicles	0	0	0	0	0.2	0	0	0.1	0	0	0	0	0	0	0	0	0
4+ Axle Trucks	0	7	8	15	19	1	3	23	3	14	0	17	0	0	0	0	55
% 4+ Axle Trucks	0	1	1.4	1.2	3.5	16.7	1.8	3.2	1	0.9	0	0.9	0	0	0	0	1.4

Start Time	Sierra Avenue Southbound				I-15 Southbound Off Ramp Westbound				Sierra Avenue Northbound				I-15 Southbound On Ramp Eastbound				Int. Total
	Left	Thru	Right	App. Total	Left	Thru	Right	App. Total	Left	Thru	Right	App. Total	Left	Thru	Right	App. Total	
Peak Hour Analysis From 04:00 PM to 05:45 PM - Peak 1 of 1																	
Peak Hour for Entire Intersection Begins at 04:45 PM																	
04:45 PM	0	87	89	176	72	1	22	95	42	211	0	253	0	0	0	0	524
05:00 PM	0	91	63	154	58	0	19	77	46	186	0	232	0	0	0	0	463
05:15 PM	0	91	69	160	73	1	24	98	35	200	0	235	0	0	0	0	493
05:30 PM	0	91	71	162	56	1	25	82	37	193	0	230	0	0	0	0	474
Total Volume	0	360	292	652	259	3	90	352	160	790	0	950	0	0	0	0	1954
% App. Total	0	55.2	44.8		73.6	0.9	25.6		16.8	83.2	0		0	0	0		
PHF	.000	.989	.820	.926	.887	.750	.900	.898	.870	.936	.000	.939	.000	.000	.000	.000	.932

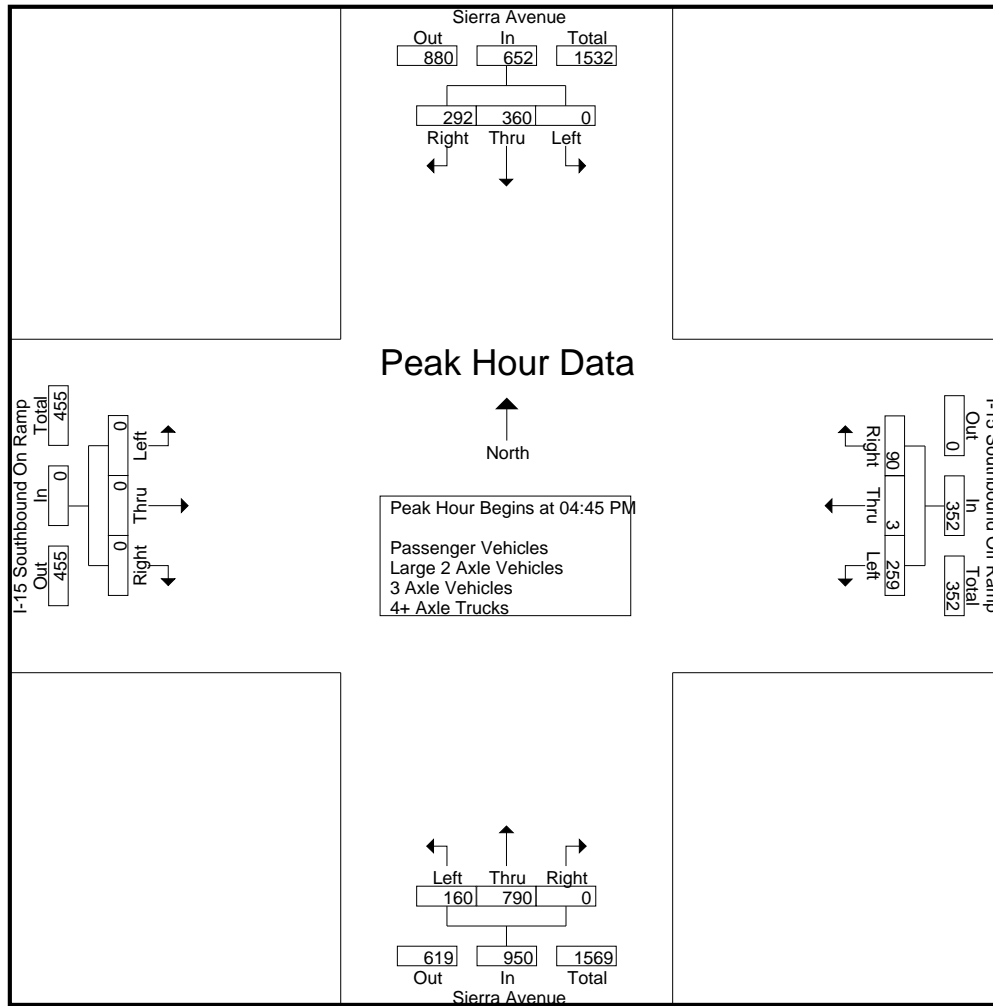

Peak Hour Analysis From 04:00 PM to 05:45 PM - Peak 1 of 1
 Peak Hour for Each Approach Begins at:

	04:45 PM				04:00 PM				04:30 PM				04:00 PM			
+0 mins.	0	87	89	176	94	1	25	120	47	213	0	260	0	0	0	0
+15 mins.	0	91	63	154	76	1	24	101	42	211	0	253	0	0	0	0
+30 mins.	0	91	69	160	46	1	18	65	46	186	0	232	0	0	0	0
+45 mins.	0	91	71	162	72	1	22	95	35	200	0	235	0	0	0	0
Total Volume	0	360	292	652	288	4	89	381	170	810	0	980	0	0	0	0
% App. Total	0	55.2	44.8		75.6	1	23.4		17.3	82.7	0		0	0	0	
PHF	.000	.989	.820	.926	.766	1.000	.890	.794	.904	.951	.000	.942	.000	.000	.000	.000

City of Fontana
 N/S: Sierra Avenue
 E/W: I-15 Southbound Ramps
 Weather: Clear

File Name : 04_FON_Sierra_15S PM
 Site Code : 12218022
 Start Date : 1/24/2018
 Page No : 1

Groups Printed- Passenger Vehicles

Start Time	Sierra Avenue Southbound				I-15 Southbound Off Ramp Westbound				Sierra Avenue Northbound				I-15 Southbound On Ramp Eastbound				Int. Total
	Left	Thru	Right	App. Total	Left	Thru	Right	App. Total	Left	Thru	Right	App. Total	Left	Thru	Right	App. Total	
04:00 PM	0	101	51	152	92	1	24	117	27	161	0	188	0	0	0	0	457
04:15 PM	0	83	80	163	72	1	21	94	35	166	0	201	0	0	0	0	458
04:30 PM	0	75	65	140	43	0	17	60	45	208	0	253	0	0	0	0	453
04:45 PM	0	84	87	171	70	1	21	92	41	211	0	252	0	0	0	0	515
Total	0	343	283	626	277	3	83	363	148	746	0	894	0	0	0	0	1883
05:00 PM	0	90	59	149	57	0	18	75	46	183	0	229	0	0	0	0	453
05:15 PM	0	88	66	154	65	1	24	90	34	195	0	229	0	0	0	0	473
05:30 PM	0	88	67	155	54	0	24	78	36	190	0	226	0	0	0	0	459
05:45 PM	0	73	70	143	58	0	12	70	30	194	0	224	0	0	0	0	437
Total	0	339	262	601	234	1	78	313	146	762	0	908	0	0	0	0	1822
Grand Total	0	682	545	1227	511	4	161	676	294	1508	0	1802	0	0	0	0	3705
Apprch %	0	55.6	44.4		75.6	0.6	23.8		16.3	83.7	0		0	0	0		
Total %	0	18.4	14.7	33.1	13.8	0.1	4.3	18.2	7.9	40.7	0	48.6	0	0	0	0	

Start Time	Sierra Avenue Southbound				I-15 Southbound Off Ramp Westbound				Sierra Avenue Northbound				I-15 Southbound On Ramp Eastbound				Int. Total
	Left	Thru	Right	App. Total	Left	Thru	Right	App. Total	Left	Thru	Right	App. Total	Left	Thru	Right	App. Total	
Peak Hour Analysis From 04:45 PM to 05:30 PM - Peak 1 of 1																	
Peak Hour for Entire Intersection Begins at 04:45 PM																	
04:45 PM	0	84	87	171	70	1	21	92	41	211	0	252	0	0	0	0	515
05:00 PM	0	90	59	149	57	0	18	75	46	183	0	229	0	0	0	0	453
05:15 PM	0	88	66	154	65	1	24	90	34	195	0	229	0	0	0	0	473
05:30 PM	0	88	67	155	54	0	24	78	36	190	0	226	0	0	0	0	459
Total Volume	0	350	279	629	246	2	87	335	157	779	0	936	0	0	0	0	1900
% App. Total	0	55.6	44.4		73.4	0.6	26		16.8	83.2	0		0	0	0		
PHF	.000	.972	.802	.920	.879	.500	.906	.910	.853	.923	.000	.929	.000	.000	.000	.000	.922

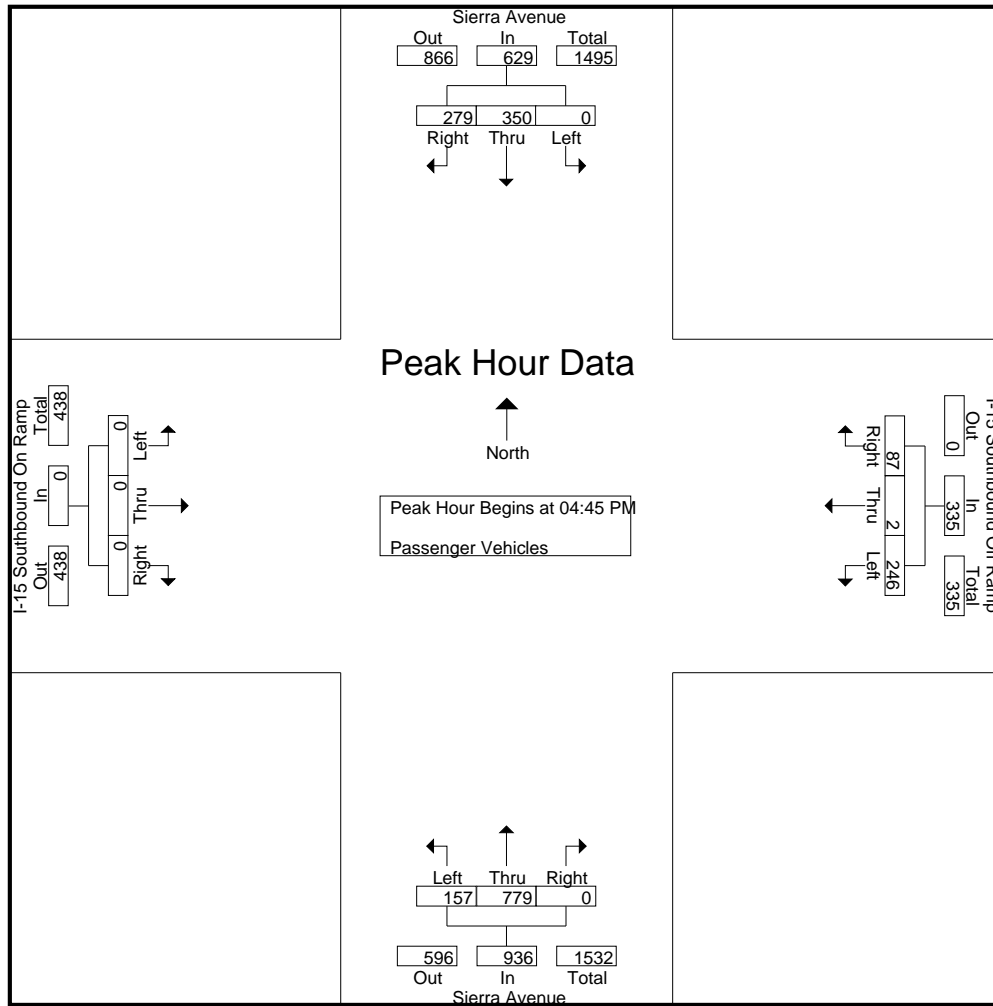

Peak Hour Analysis From 04:45 PM to 05:30 PM - Peak 1 of 1
 Peak Hour for Each Approach Begins at:

	04:45 PM				04:45 PM				04:45 PM				04:45 PM			
+0 mins.	0	84	87	171	70	1	21	92	41	211	0	252	0	0	0	0
+15 mins.	0	90	59	149	57	0	18	75	46	183	0	229	0	0	0	0
+30 mins.	0	88	66	154	65	1	24	90	34	195	0	229	0	0	0	0
+45 mins.	0	88	67	155	54	0	24	78	36	190	0	226	0	0	0	0
Total Volume	0	350	279	629	246	2	87	335	157	779	0	936	0	0	0	0
% App. Total	0	55.6	44.4		73.4	0.6	26		16.8	83.2	0		0	0	0	0
PHF	.000	.972	.802	.920	.879	.500	.906	.910	.853	.923	.000	.929	.000	.000	.000	.000

City of Fontana
 N/S: Sierra Avenue
 E/W: I-15 Southbound Ramps
 Weather: Clear

File Name : 04_FON_Sierra_15S PM
 Site Code : 12218022
 Start Date : 1/24/2018
 Page No : 1

Groups Printed- Large 2 Axle Vehicles

Start Time	Sierra Avenue Southbound				I-15 Southbound Off Ramp Westbound				Sierra Avenue Northbound				I-15 Southbound On Ramp Eastbound				Int. Total
	Left	Thru	Right	App. Total	Left	Thru	Right	App. Total	Left	Thru	Right	App. Total	Left	Thru	Right	App. Total	
04:00 PM	0	1	1	2	1	0	1	2	1	0	0	1	0	0	0	0	5
04:15 PM	0	0	1	1	1	0	1	2	0	0	0	0	0	0	0	0	3
04:30 PM	0	1	2	3	1	0	1	2	1	4	0	5	0	0	0	0	10
04:45 PM	0	2	2	4	0	0	0	0	1	0	0	1	0	0	0	0	5
Total	0	4	6	10	3	0	3	6	3	4	0	7	0	0	0	0	23
05:00 PM	0	1	2	3	1	0	1	2	0	0	0	0	0	0	0	0	5
05:15 PM	0	2	1	3	1	0	0	1	0	3	0	3	0	0	0	0	7
05:30 PM	0	1	3	4	0	1	1	2	1	1	0	2	0	0	0	0	8
05:45 PM	0	0	0	0	0	0	0	0	0	4	0	4	0	0	0	0	4
Total	0	4	6	10	2	1	2	5	1	8	0	9	0	0	0	0	24
Grand Total	0	8	12	20	5	1	5	11	4	12	0	16	0	0	0	0	47
Apprch %	0	40	60		45.5	9.1	45.5		25	75	0		0	0	0		
Total %	0	17	25.5	42.6	10.6	2.1	10.6	23.4	8.5	25.5	0	34	0	0	0	0	

Start Time	Sierra Avenue Southbound				I-15 Southbound Off Ramp Westbound				Sierra Avenue Northbound				I-15 Southbound On Ramp Eastbound				Int. Total
	Left	Thru	Right	App. Total	Left	Thru	Right	App. Total	Left	Thru	Right	App. Total	Left	Thru	Right	App. Total	
Peak Hour Analysis From 04:45 PM to 05:30 PM - Peak 1 of 1																	
Peak Hour for Entire Intersection Begins at 04:45 PM																	
04:45 PM	0	2	2	4	0	0	0	0	1	0	0	1	0	0	0	0	5
05:00 PM	0	1	2	3	1	0	1	2	0	0	0	0	0	0	0	0	5
05:15 PM	0	2	1	3	1	0	0	1	0	3	0	3	0	0	0	0	7
05:30 PM	0	1	3	4	0	1	1	2	1	1	0	2	0	0	0	0	8
Total Volume	0	6	8	14	2	1	2	5	2	4	0	6	0	0	0	0	25
% App. Total	0	42.9	57.1		40	20	40		33.3	66.7	0		0	0	0		
PHF	.000	.750	.667	.875	.500	.250	.500	.625	.500	.333	.000	.500	.000	.000	.000	.000	.781

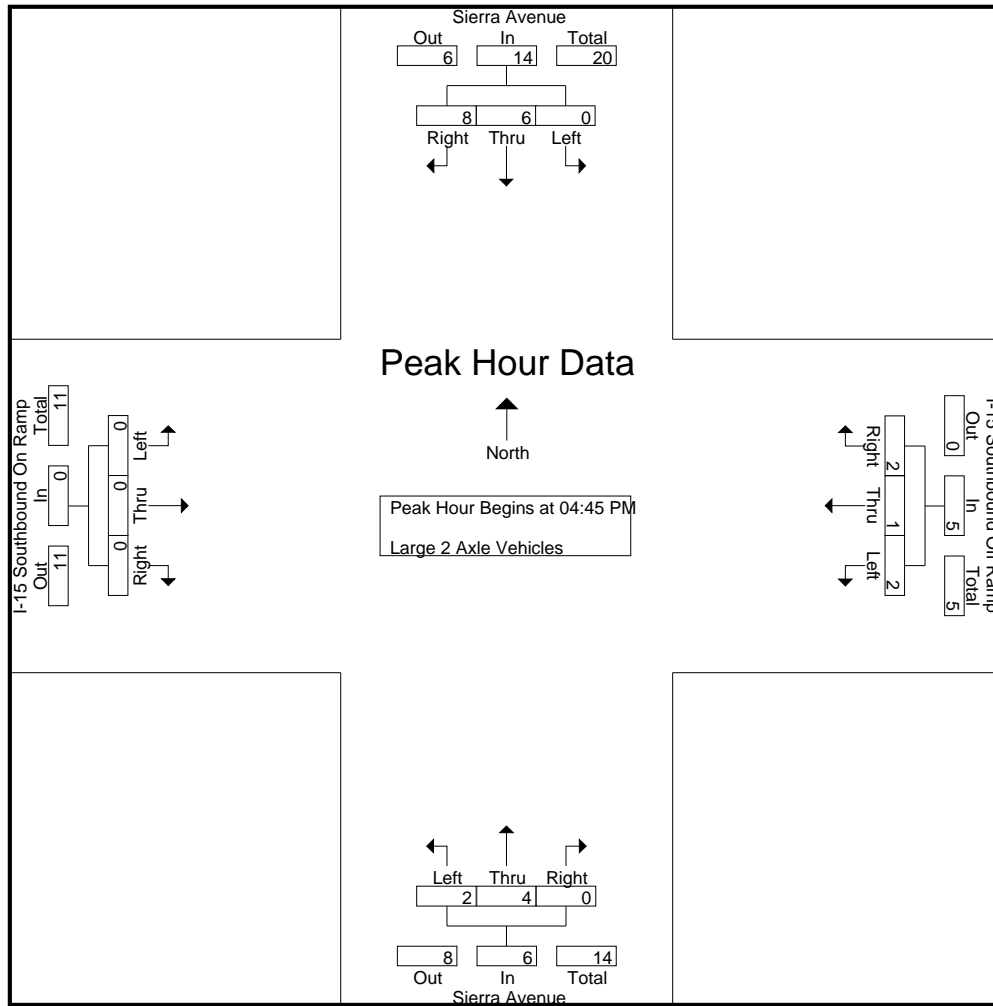

Peak Hour Analysis From 04:45 PM to 05:30 PM - Peak 1 of 1
 Peak Hour for Each Approach Begins at:

	04:45 PM				04:45 PM				04:45 PM				04:45 PM				
+0 mins.	0	2	2	4	0	0	0	0	1	0	0	0	1	0	0	0	0
+15 mins.	0	1	2	3	1	0	1	2	0	0	0	0	0	0	0	0	0
+30 mins.	0	2	1	3	1	0	0	1	0	3	0	3	0	0	0	0	
+45 mins.	0	1	3	4	0	1	1	2	1	1	0	2	0	0	0	0	
Total Volume	0	6	8	14	2	1	2	5	2	4	0	6	0	0	0	0	
% App. Total	0	42.9	57.1		40	20	40		33.3	66.7	0		0	0	0		
PHF	.000	.750	.667	.875	.500	.250	.500	.625	.500	.333	.000	.500	.000	.000	.000	.000	

City of Fontana
 N/S: Sierra Avenue
 E/W: I-15 Southbound Ramps
 Weather: Clear

File Name : 04_FON_Sierra_15S PM
 Site Code : 12218022
 Start Date : 1/24/2018
 Page No : 1

Groups Printed- 3 Axle Vehicles

Start Time	Sierra Avenue Southbound				I-15 Southbound Off Ramp Westbound				Sierra Avenue Northbound				I-15 Southbound On Ramp Eastbound				Int. Total
	Left	Thru	Right	App. Total	Left	Thru	Right	App. Total	Left	Thru	Right	App. Total	Left	Thru	Right	App. Total	
04:00 PM	0	0	0	0	0	0	0	0	0	0	0	0	0	0	0	0	0
04:15 PM	0	0	0	0	0	0	0	0	0	0	0	0	0	0	0	0	0
04:30 PM	0	0	0	0	1	0	0	1	0	0	0	0	0	0	0	0	1
04:45 PM	0	0	0	0	0	0	0	0	0	0	0	0	0	0	0	0	0
Total	0	0	0	0	1	0	0	1	0	0	0	0	0	0	0	0	1
05:00 PM	0	0	0	0	0	0	0	0	0	0	0	0	0	0	0	0	0
05:15 PM	0	0	0	0	0	0	0	0	0	0	0	0	0	0	0	0	0
05:30 PM	0	0	0	0	0	0	0	0	0	0	0	0	0	0	0	0	0
05:45 PM	0	0	0	0	0	0	0	0	0	0	0	0	0	0	0	0	0
Total	0	0	0	0	0	0	0	0	0	0	0	0	0	0	0	0	0
Grand Total	0	0	0	0	1	0	0	1	0	0	0	0	0	0	0	0	1
Apprch %	0	0	0		100	0	0		0	0	0		0	0	0		
Total %	0	0	0	0	100	0	0	100	0	0	0	0	0	0	0	0	

Start Time	Sierra Avenue Southbound				I-15 Southbound Off Ramp Westbound				Sierra Avenue Northbound				I-15 Southbound On Ramp Eastbound				Int. Total
	Left	Thru	Right	App. Total	Left	Thru	Right	App. Total	Left	Thru	Right	App. Total	Left	Thru	Right	App. Total	
04:45 PM	0	0	0	0	0	0	0	0	0	0	0	0	0	0	0	0	0
05:00 PM	0	0	0	0	0	0	0	0	0	0	0	0	0	0	0	0	0
05:15 PM	0	0	0	0	0	0	0	0	0	0	0	0	0	0	0	0	0
05:30 PM	0	0	0	0	0	0	0	0	0	0	0	0	0	0	0	0	0
Total Volume	0	0	0	0	0	0	0	0	0	0	0	0	0	0	0	0	0
% App. Total	0	0	0		0	0	0		0	0	0		0	0	0		
PHF	.000	.000	.000	.000	.000	.000	.000	.000	.000	.000	.000	.000	.000	.000	.000	.000	.000

Peak Hour Analysis From 04:45 PM to 05:30 PM - Peak 1 of 1

Peak Hour for Entire Intersection Begins at 04:45 PM

City of Fontana
 N/S: Sierra Avenue
 E/W: I-15 Southbound Ramps
 Weather: Clear

File Name : 04_FON_Sierra_15S PM
 Site Code : 12218022
 Start Date : 1/24/2018
 Page No : 2

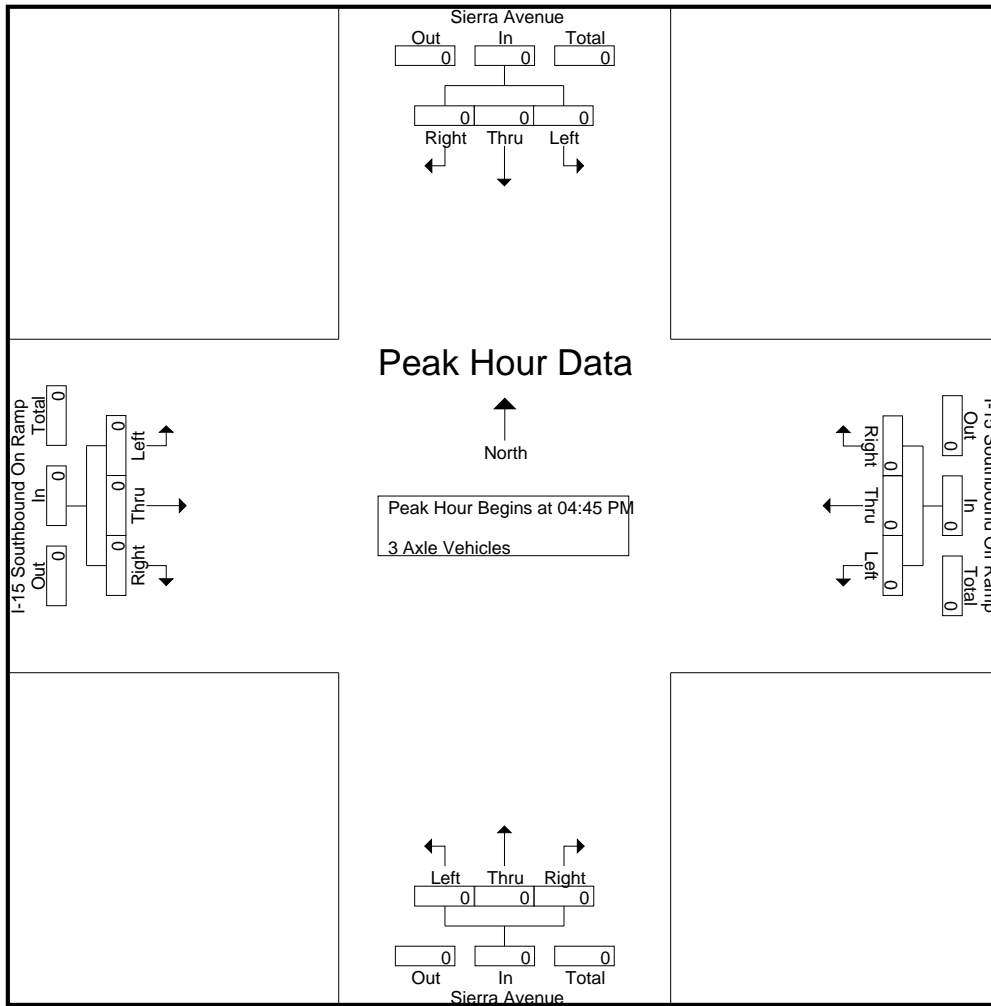

Peak Hour Analysis From 04:45 PM to 05:30 PM - Peak 1 of 1
 Peak Hour for Each Approach Begins at:

	04:45 PM				04:45 PM				04:45 PM				04:45 PM			
+0 mins.	0	0	0	0	0	0	0	0	0	0	0	0	0	0	0	0
+15 mins.	0	0	0	0	0	0	0	0	0	0	0	0	0	0	0	0
+30 mins.	0	0	0	0	0	0	0	0	0	0	0	0	0	0	0	0
+45 mins.	0	0	0	0	0	0	0	0	0	0	0	0	0	0	0	0
Total Volume	0	0	0	0	0	0	0	0	0	0	0	0	0	0	0	0
% App. Total	0	0	0	0	0	0	0	0	0	0	0	0	0	0	0	0
PHF	.000	.000	.000	.000	.000	.000	.000	.000	.000	.000	.000	.000	.000	.000	.000	.000

City of Fontana
 N/S: Sierra Avenue
 E/W: I-15 Southbound Ramps
 Weather: Clear

File Name : 04_FON_Sierra_15S PM
 Site Code : 12218022
 Start Date : 1/24/2018
 Page No : 1

Groups Printed- 4+ Axle Trucks

Start Time	Sierra Avenue Southbound				I-15 Southbound Off Ramp Westbound				Sierra Avenue Northbound				I-15 Southbound On Ramp Eastbound				Int. Total
	Left	Thru	Right	App. Total	Left	Thru	Right	App. Total	Left	Thru	Right	App. Total	Left	Thru	Right	App. Total	
04:00 PM	0	2	0	2	1	0	0	1	1	3	0	4	0	0	0	0	7
04:15 PM	0	0	0	0	3	0	2	5	0	1	0	1	0	0	0	0	6
04:30 PM	0	1	3	4	1	1	0	2	1	1	0	2	0	0	0	0	8
04:45 PM	0	1	0	1	2	0	1	3	0	0	0	0	0	0	0	0	4
Total	0	4	3	7	7	1	3	11	2	5	0	7	0	0	0	0	25
05:00 PM	0	0	2	2	0	0	0	0	0	3	0	3	0	0	0	0	5
05:15 PM	0	1	2	3	7	0	0	7	1	2	0	3	0	0	0	0	13
05:30 PM	0	2	1	3	2	0	0	2	0	2	0	2	0	0	0	0	7
05:45 PM	0	0	0	0	3	0	0	3	0	2	0	2	0	0	0	0	5
Total	0	3	5	8	12	0	0	12	1	9	0	10	0	0	0	0	30
Grand Total	0	7	8	15	19	1	3	23	3	14	0	17	0	0	0	0	55
Apprch %	0	46.7	53.3		82.6	4.3	13		17.6	82.4	0		0	0	0		
Total %	0	12.7	14.5	27.3	34.5	1.8	5.5	41.8	5.5	25.5	0	30.9	0	0	0	0	

Start Time	Sierra Avenue Southbound				I-15 Southbound Off Ramp Westbound				Sierra Avenue Northbound				I-15 Southbound On Ramp Eastbound				Int. Total
	Left	Thru	Right	App. Total	Left	Thru	Right	App. Total	Left	Thru	Right	App. Total	Left	Thru	Right	App. Total	
Peak Hour Analysis From 04:45 PM to 05:30 PM - Peak 1 of 1																	
Peak Hour for Entire Intersection Begins at 04:45 PM																	
04:45 PM	0	1	0	1	2	0	1	3	0	0	0	0	0	0	0	0	4
05:00 PM	0	0	2	2	0	0	0	0	0	3	0	3	0	0	0	0	5
05:15 PM	0	1	2	3	7	0	0	7	1	2	0	3	0	0	0	0	13
05:30 PM	0	2	1	3	2	0	0	2	0	2	0	2	0	0	0	0	7
Total Volume	0	4	5	9	11	0	1	12	1	7	0	8	0	0	0	0	29
% App. Total	0	44.4	55.6		91.7	0	8.3		12.5	87.5	0		0	0	0		
PHF	.000	.500	.625	.750	.393	.000	.250	.429	.250	.583	.000	.667	.000	.000	.000	.000	.558

City of Fontana
 N/S: Sierra Avenue
 E/W: I-15 Southbound Ramps
 Weather: Clear

File Name : 04_FON_Sierra_15S PM
 Site Code : 12218022
 Start Date : 1/24/2018
 Page No : 2

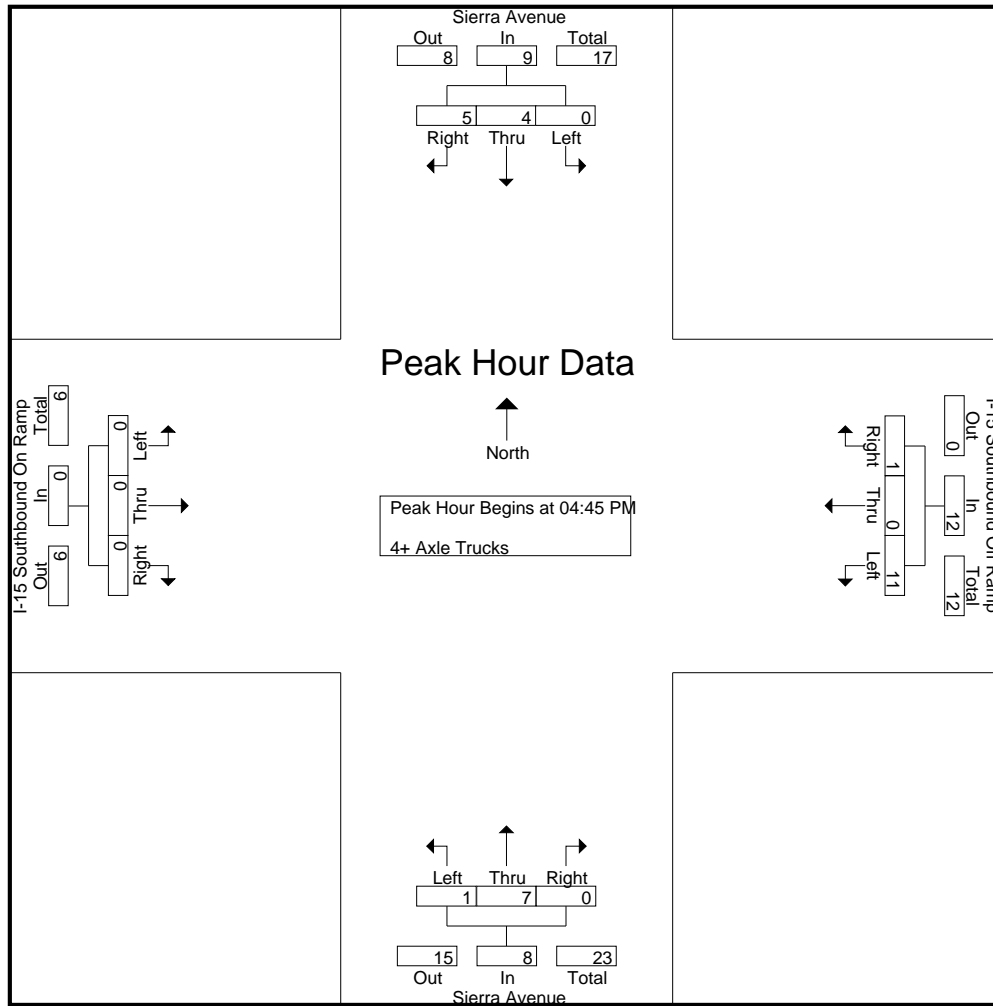

Peak Hour Analysis From 04:45 PM to 05:30 PM - Peak 1 of 1
 Peak Hour for Each Approach Begins at:

	04:45 PM				04:45 PM				04:45 PM				04:45 PM			
+0 mins.	0	1	0	1	2	0	1	3	0	0	0	0	0	0	0	0
+15 mins.	0	0	2	2	0	0	0	0	0	3	0	3	0	0	0	0
+30 mins.	0	1	2	3	7	0	0	7	1	2	0	3	0	0	0	0
+45 mins.	0	2	1	3	2	0	0	2	0	2	0	2	0	0	0	0
Total Volume	0	4	5	9	11	0	1	12	1	7	0	8	0	0	0	0
% App. Total	0	44.4	55.6		91.7	0	8.3		12.5	87.5	0		0	0	0	
PHF	.000	.500	.625	.750	.393	.000	.250	.429	.250	.583	.000	.667	.000	.000	.000	.000

City of Fontana
 N/S: Sierra Avenue
 E/W: I-15 Northbound Ramps
 Weather: Clear

File Name : 05_FON_Sierra_15N AM
 Site Code : 12218022
 Start Date : 1/24/2018
 Page No : 1

Groups Printed- Passenger Vehicles - Large 2 Axle Vehicles - 3 Axle Vehicles - 4+ Axle Trucks

Start Time	Sierra Avenue Southbound				I-15 Northbound On Ramp Westbound				Sierra Avenue Northbound				I-15 Northbound Off Ramp Eastbound				Int. Total
	Left	Thru	Right	App. Total	Left	Thru	Right	App. Total	Left	Thru	Right	App. Total	Left	Thru	Right	App. Total	
07:00 AM	15	168	0	183	0	0	0	0	0	136	36	172	44	0	31	75	430
07:15 AM	19	175	0	194	0	0	0	0	0	169	51	220	66	0	40	106	520
07:30 AM	19	211	0	230	0	0	0	0	0	124	49	173	49	0	43	92	495
07:45 AM	7	159	0	166	0	0	0	0	0	107	47	154	45	0	45	90	410
Total	60	713	0	773	0	0	0	0	0	536	183	719	204	0	159	363	1855
08:00 AM	13	150	0	163	0	0	0	0	0	112	38	150	43	0	31	74	387
08:15 AM	10	155	0	165	0	0	0	0	0	83	44	127	50	0	22	72	364
08:30 AM	10	135	0	145	0	0	0	0	0	73	46	119	36	0	31	67	331
08:45 AM	15	136	0	151	0	0	0	0	0	63	42	105	43	2	23	68	324
Total	48	576	0	624	0	0	0	0	0	331	170	501	172	2	107	281	1406
Grand Total	108	1289	0	1397	0	0	0	0	0	867	353	1220	376	2	266	644	3261
Apprch %	7.7	92.3	0		0	0	0		0	71.1	28.9		58.4	0.3	41.3		
Total %	3.3	39.5	0	42.8	0	0	0	0	0	26.6	10.8	37.4	11.5	0.1	8.2	19.7	
Passenger Vehicles	102	1233	0	1335	0	0	0	0	0	834	318	1152	347	1	246	594	3081
% Passenger Vehicles	94.4	95.7	0	95.6	0	0	0	0	0	96.2	90.1	94.4	92.3	50	92.5	92.2	94.5
Large 2 Axle Vehicles	5	23	0	28	0	0	0	0	0	10	15	25	22	0	3	25	78
% Large 2 Axle Vehicles	4.6	1.8	0	2	0	0	0	0	0	1.2	4.2	2	5.9	0	1.1	3.9	2.4
3 Axle Vehicles	1	8	0	9	0	0	0	0	0	9	5	14	1	0	1	2	25
% 3 Axle Vehicles	0.9	0.6	0	0.6	0	0	0	0	0	1	1.4	1.1	0.3	0	0.4	0.3	0.8
4+ Axle Trucks	0	25	0	25	0	0	0	0	0	14	15	29	6	1	16	23	77
% 4+ Axle Trucks	0	1.9	0	1.8	0	0	0	0	0	1.6	4.2	2.4	1.6	50	6	3.6	2.4

Start Time	Sierra Avenue Southbound				I-15 Northbound On Ramp Westbound				Sierra Avenue Northbound				I-15 Northbound Off Ramp Eastbound				Int. Total
	Left	Thru	Right	App. Total	Left	Thru	Right	App. Total	Left	Thru	Right	App. Total	Left	Thru	Right	App. Total	
Peak Hour Analysis From 07:00 AM to 08:45 AM - Peak 1 of 1																	
Peak Hour for Entire Intersection Begins at 07:00 AM																	
07:00 AM	15	168	0	183	0	0	0	0	0	136	36	172	44	0	31	75	430
07:15 AM	19	175	0	194	0	0	0	0	0	169	51	220	66	0	40	106	520
07:30 AM	19	211	0	230	0	0	0	0	0	124	49	173	49	0	43	92	495
07:45 AM	7	159	0	166	0	0	0	0	0	107	47	154	45	0	45	90	410
Total Volume	60	713	0	773	0	0	0	0	0	536	183	719	204	0	159	363	1855
% App. Total	7.8	92.2	0		0	0	0		0	74.5	25.5		56.2	0	43.8		
PHF	.789	.845	.000	.840	.000	.000	.000	.000	.000	.793	.897	.817	.773	.000	.883	.856	.892

City of Fontana
 N/S: Sierra Avenue
 E/W: I-15 Northbound Ramps
 Weather: Clear

File Name : 05_FON_Sierra_15N AM
 Site Code : 12218022
 Start Date : 1/24/2018
 Page No : 2

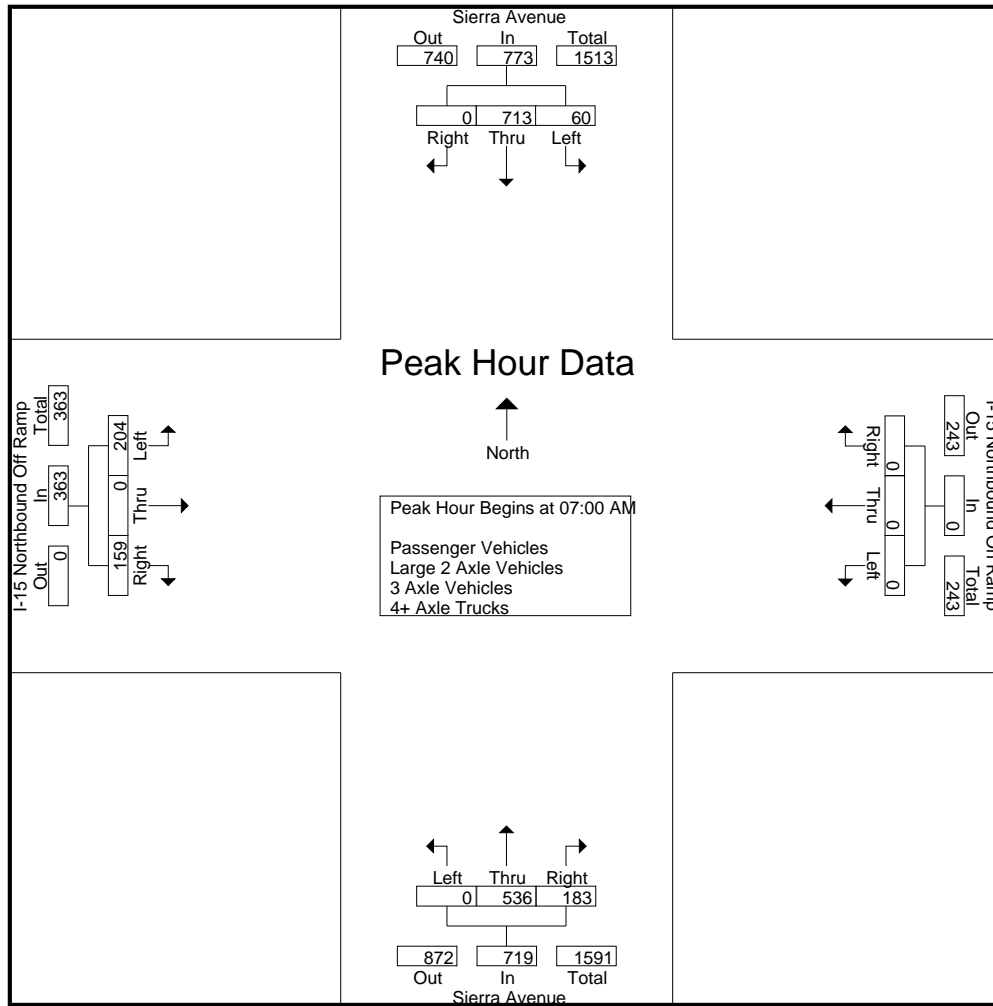

Peak Hour Analysis From 07:00 AM to 08:45 AM - Peak 1 of 1
 Peak Hour for Each Approach Begins at:

	07:00 AM				07:00 AM				07:00 AM				07:00 AM			
+0 mins.	15	168	0	183	0	0	0	0	0	136	36	172	44	0	31	75
+15 mins.	19	175	0	194	0	0	0	0	0	169	51	220	66	0	40	106
+30 mins.	19	211	0	230	0	0	0	0	0	124	49	173	49	0	43	92
+45 mins.	7	159	0	166	0	0	0	0	0	107	47	154	45	0	45	90
Total Volume	60	713	0	773	0	0	0	0	0	536	183	719	204	0	159	363
% App. Total	7.8	92.2	0		0	0	0	0	0	74.5	25.5		56.2	0	43.8	
PHF	.789	.845	.000	.840	.000	.000	.000	.000	.000	.793	.897	.817	.773	.000	.883	.856

City of Fontana
 N/S: Sierra Avenue
 E/W: I-15 Northbound Ramps
 Weather: Clear

File Name : 05_FON_Sierra_15N AM
 Site Code : 12218022
 Start Date : 1/24/2018
 Page No : 1

Groups Printed- Passenger Vehicles

Start Time	Sierra Avenue Southbound				I-15 Northbound On Ramp Westbound				Sierra Avenue Northbound				I-15 Northbound Off Ramp Eastbound				Int. Total
	Left	Thru	Right	App. Total	Left	Thru	Right	App. Total	Left	Thru	Right	App. Total	Left	Thru	Right	App. Total	
07:00 AM	15	159	0	174	0	0	0	0	0	134	32	166	41	0	27	68	408
07:15 AM	18	172	0	190	0	0	0	0	0	167	50	217	61	0	37	98	505
07:30 AM	16	207	0	223	0	0	0	0	0	118	42	160	43	0	40	83	466
07:45 AM	5	147	0	152	0	0	0	0	0	100	44	144	43	0	43	86	382
Total	54	685	0	739	0	0	0	0	0	519	168	687	188	0	147	335	1761
08:00 AM	13	141	0	154	0	0	0	0	0	107	36	143	41	0	29	70	367
08:15 AM	10	147	0	157	0	0	0	0	0	81	40	121	45	0	20	65	343
08:30 AM	10	130	0	140	0	0	0	0	0	69	39	108	34	0	28	62	310
08:45 AM	15	130	0	145	0	0	0	0	0	58	35	93	39	1	22	62	300
Total	48	548	0	596	0	0	0	0	0	315	150	465	159	1	99	259	1320
Grand Total	102	1233	0	1335	0	0	0	0	0	834	318	1152	347	1	246	594	3081
Apprch %	7.6	92.4	0		0	0	0		0	72.4	27.6		58.4	0.2	41.4		
Total %	3.3	40	0	43.3	0	0	0	0	0	27.1	10.3	37.4	11.3	0	8	19.3	

Start Time	Sierra Avenue Southbound				I-15 Northbound On Ramp Westbound				Sierra Avenue Northbound				I-15 Northbound Off Ramp Eastbound				Int. Total
	Left	Thru	Right	App. Total	Left	Thru	Right	App. Total	Left	Thru	Right	App. Total	Left	Thru	Right	App. Total	
Peak Hour Analysis From 07:00 AM to 07:45 AM - Peak 1 of 1																	
Peak Hour for Entire Intersection Begins at 07:00 AM																	
07:00 AM	15	159	0	174	0	0	0	0	0	134	32	166	41	0	27	68	408
07:15 AM	18	172	0	190	0	0	0	0	0	167	50	217	61	0	37	98	505
07:30 AM	16	207	0	223	0	0	0	0	0	118	42	160	43	0	40	83	466
07:45 AM	5	147	0	152	0	0	0	0	0	100	44	144	43	0	43	86	382
Total Volume	54	685	0	739	0	0	0	0	0	519	168	687	188	0	147	335	1761
% App. Total	7.3	92.7	0		0	0	0		0	75.5	24.5		56.1	0	43.9		
PHF	.750	.827	.000	.828	.000	.000	.000	.000	.000	.777	.840	.791	.770	.000	.855	.855	.872

City of Fontana
 N/S: Sierra Avenue
 E/W: I-15 Northbound Ramps
 Weather: Clear

File Name : 05_FON_Sierra_15N AM
 Site Code : 12218022
 Start Date : 1/24/2018
 Page No : 2

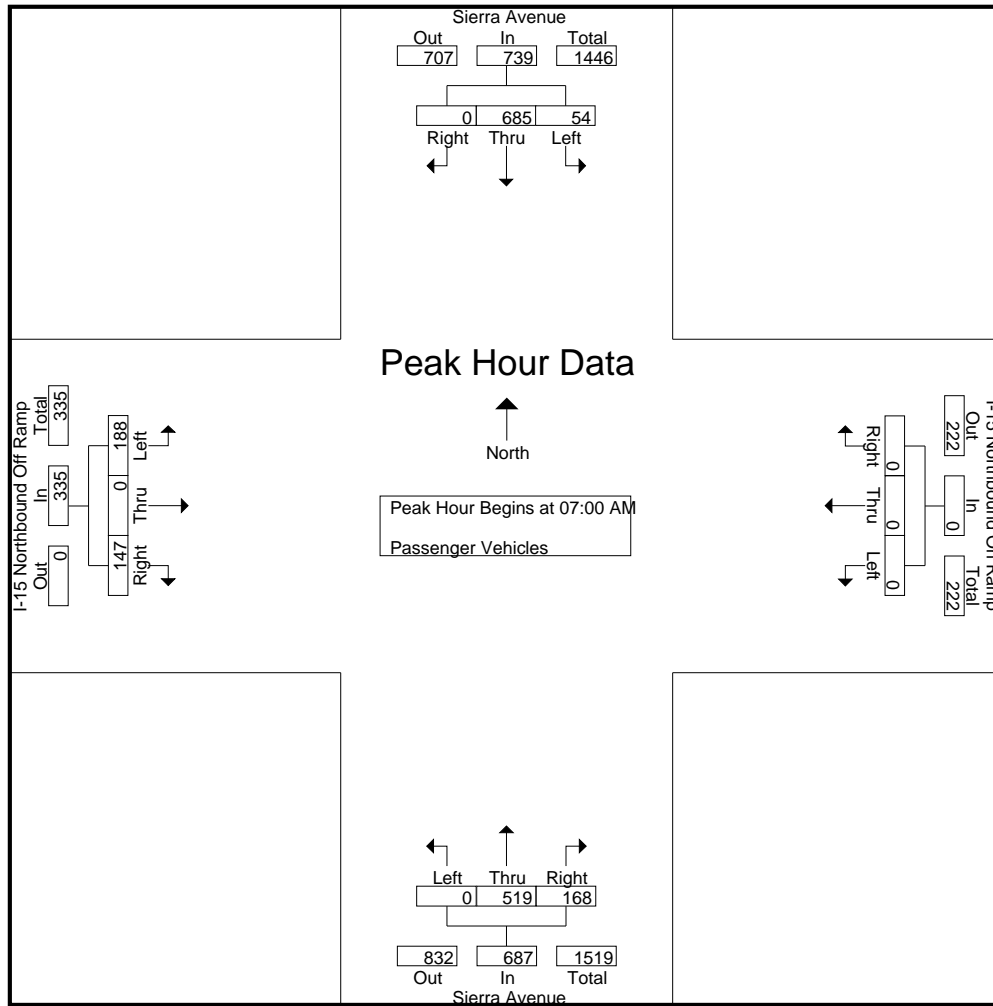

Peak Hour Analysis From 07:00 AM to 07:45 AM - Peak 1 of 1
 Peak Hour for Each Approach Begins at:

	07:00 AM				07:00 AM				07:00 AM				07:00 AM			
+0 mins.	15	159	0	174	0	0	0	0	0	134	32	166	41	0	27	68
+15 mins.	18	172	0	190	0	0	0	0	0	167	50	217	61	0	37	98
+30 mins.	16	207	0	223	0	0	0	0	0	118	42	160	43	0	40	83
+45 mins.	5	147	0	152	0	0	0	0	0	100	44	144	43	0	43	86
Total Volume	54	685	0	739	0	0	0	0	0	519	168	687	188	0	147	335
% App. Total	7.3	92.7	0		0	0	0		0	75.5	24.5		56.1	0	43.9	
PHF	.750	.827	.000	.828	.000	.000	.000	.000	.000	.777	.840	.791	.770	.000	.855	.855

City of Fontana
 N/S: Sierra Avenue
 E/W: I-15 Northbound Ramps
 Weather: Clear

File Name : 05_FON_Sierra_15N AM
 Site Code : 12218022
 Start Date : 1/24/2018
 Page No : 1

Groups Printed- Large 2 Axle Vehicles

Start Time	Sierra Avenue Southbound				I-15 Northbound On Ramp Westbound				Sierra Avenue Northbound				I-15 Northbound Off Ramp Eastbound				Int. Total
	Left	Thru	Right	App. Total	Left	Thru	Right	App. Total	Left	Thru	Right	App. Total	Left	Thru	Right	App. Total	
07:00 AM	0	5	0	5	0	0	0	0	0	1	1	2	3	0	0	3	10
07:15 AM	1	2	0	3	0	0	0	0	0	2	1	3	4	0	1	5	11
07:30 AM	2	3	0	5	0	0	0	0	0	1	4	5	5	0	1	6	16
07:45 AM	2	5	0	7	0	0	0	0	0	0	0	0	1	0	0	1	8
Total	5	15	0	20	0	0	0	0	0	4	6	10	13	0	2	15	45
08:00 AM	0	4	0	4	0	0	0	0	0	2	1	3	1	0	1	2	9
08:15 AM	0	2	0	2	0	0	0	0	0	0	1	1	4	0	0	4	7
08:30 AM	0	1	0	1	0	0	0	0	0	2	1	3	0	0	0	0	4
08:45 AM	0	1	0	1	0	0	0	0	0	2	6	8	4	0	0	4	13
Total	0	8	0	8	0	0	0	0	0	6	9	15	9	0	1	10	33
Grand Total	5	23	0	28	0	0	0	0	0	10	15	25	22	0	3	25	78
Apprch %	17.9	82.1	0		0	0	0		0	40	60		88	0	12		
Total %	6.4	29.5	0	35.9	0	0	0	0	0	12.8	19.2	32.1	28.2	0	3.8	32.1	

Start Time	Sierra Avenue Southbound				I-15 Northbound On Ramp Westbound				Sierra Avenue Northbound				I-15 Northbound Off Ramp Eastbound				Int. Total
	Left	Thru	Right	App. Total	Left	Thru	Right	App. Total	Left	Thru	Right	App. Total	Left	Thru	Right	App. Total	
07:00 AM	0	5	0	5	0	0	0	0	0	1	1	2	3	0	0	3	10
07:15 AM	1	2	0	3	0	0	0	0	0	2	1	3	4	0	1	5	11
07:30 AM	2	3	0	5	0	0	0	0	0	1	4	5	5	0	1	6	16
07:45 AM	2	5	0	7	0	0	0	0	0	0	0	0	1	0	0	1	8
Total Volume	5	15	0	20	0	0	0	0	0	4	6	10	13	0	2	15	45
% App. Total	25	75	0		0	0	0		0	40	60		86.7	0	13.3		
PHF	.625	.750	.000	.714	.000	.000	.000	.000	.000	.500	.375	.500	.650	.000	.500	.625	.703

Peak Hour Analysis From 07:00 AM to 07:45 AM - Peak 1 of 1

Peak Hour for Entire Intersection Begins at 07:00 AM

City of Fontana
 N/S: Sierra Avenue
 E/W: I-15 Northbound Ramps
 Weather: Clear

File Name : 05_FON_Sierra_15N AM
 Site Code : 12218022
 Start Date : 1/24/2018
 Page No : 2

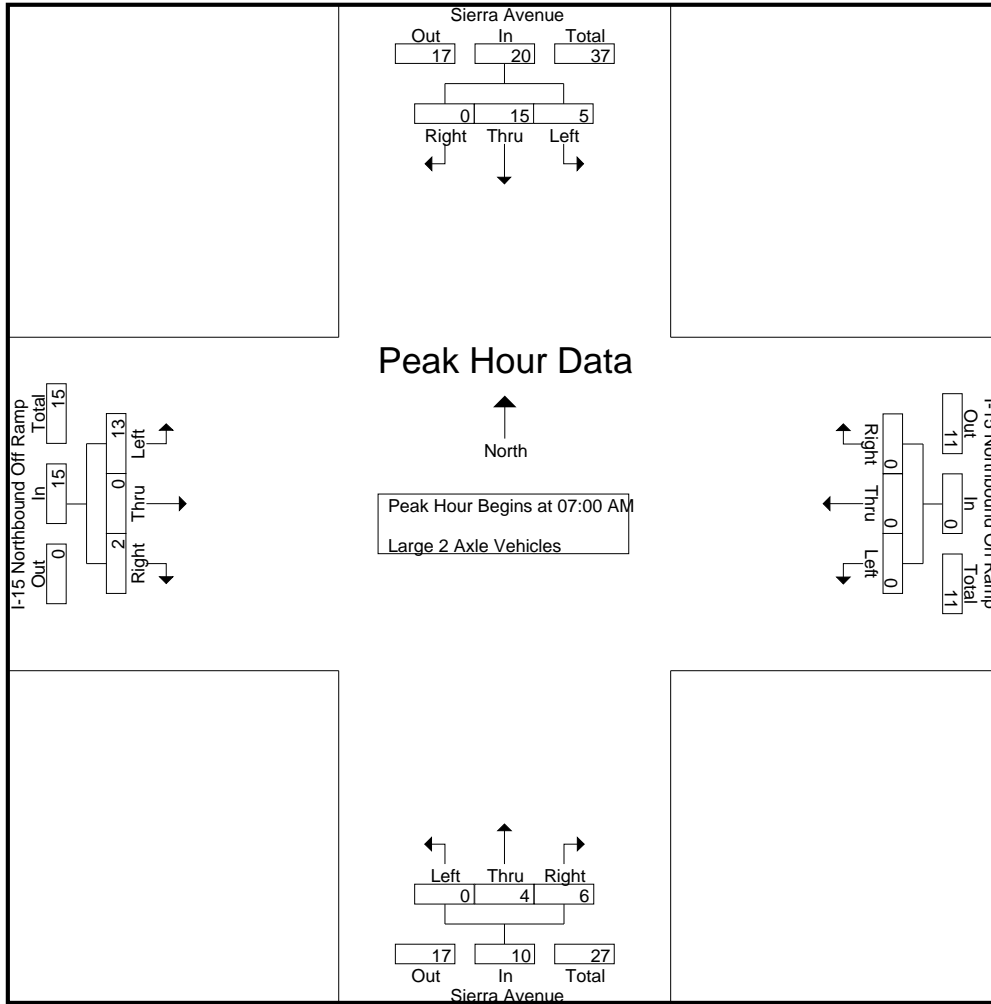

Peak Hour Analysis From 07:00 AM to 07:45 AM - Peak 1 of 1
 Peak Hour for Each Approach Begins at:

	07:00 AM				07:00 AM				07:00 AM				07:00 AM			
+0 mins.	0	5	0	5	0	0	0	0	0	1	1	2	3	0	0	3
+15 mins.	1	2	0	3	0	0	0	0	0	2	1	3	4	0	1	5
+30 mins.	2	3	0	5	0	0	0	0	0	1	4	5	5	0	1	6
+45 mins.	2	5	0	7	0	0	0	0	0	0	0	0	1	0	0	1
Total Volume	5	15	0	20	0	0	0	0	0	4	6	10	13	0	2	15
% App. Total	25	75	0		0	0	0	0	0	40	60		86.7	0	13.3	
PHF	.625	.750	.000	.714	.000	.000	.000	.000	.000	.500	.375	.500	.650	.000	.500	.625

City of Fontana
 N/S: Sierra Avenue
 E/W: I-15 Northbound Ramps
 Weather: Clear

File Name : 05_FON_Sierra_15N AM
 Site Code : 12218022
 Start Date : 1/24/2018
 Page No : 1

Groups Printed- 3 Axle Vehicles

Start Time	Sierra Avenue Southbound				I-15 Northbound On Ramp Westbound				Sierra Avenue Northbound				I-15 Northbound Off Ramp Eastbound				Int. Total	
	Left	Thru	Right	App. Total	Left	Thru	Right	App. Total	Left	Thru	Right	App. Total	Left	Thru	Right	App. Total		
07:00 AM	0	0	0	0	0	0	0	0	0	0	1	0	1	0	0	0	0	1
07:15 AM	0	0	0	0	0	0	0	0	0	0	0	0	0	0	0	0	0	0
07:30 AM	1	0	0	1	0	0	0	0	0	0	3	1	4	0	0	0	0	5
07:45 AM	0	2	0	2	0	0	0	0	0	0	2	2	4	0	0	0	0	6
Total	1	2	0	3	0	0	0	0	0	0	6	3	9	0	0	0	0	12
08:00 AM	0	0	0	0	0	0	0	0	0	0	1	0	1	0	0	0	0	1
08:15 AM	0	4	0	4	0	0	0	0	0	0	1	1	2	0	0	0	0	6
08:30 AM	0	1	0	1	0	0	0	0	0	0	1	1	2	1	0	1	2	5
08:45 AM	0	1	0	1	0	0	0	0	0	0	0	0	0	0	0	0	0	1
Total	0	6	0	6	0	0	0	0	0	0	3	2	5	1	0	1	2	13
Grand Total	1	8	0	9	0	0	0	0	0	0	9	5	14	1	0	1	2	25
Apprch %	11.1	88.9	0		0	0	0		0	64.3	35.7			50	0	50		
Total %	4	32	0	36	0	0	0	0	0	0	36	20	56	4	0	4	8	

Start Time	Sierra Avenue Southbound				I-15 Northbound On Ramp Westbound				Sierra Avenue Northbound				I-15 Northbound Off Ramp Eastbound				Int. Total	
	Left	Thru	Right	App. Total	Left	Thru	Right	App. Total	Left	Thru	Right	App. Total	Left	Thru	Right	App. Total		
07:00 AM	0	0	0	0	0	0	0	0	0	0	1	0	1	0	0	0	0	1
07:15 AM	0	0	0	0	0	0	0	0	0	0	0	0	0	0	0	0	0	0
07:30 AM	1	0	0	1	0	0	0	0	0	0	3	1	4	0	0	0	0	5
07:45 AM	0	2	0	2	0	0	0	0	0	0	2	2	4	0	0	0	0	6
Total Volume	1	2	0	3	0	0	0	0	0	0	6	3	9	0	0	0	0	12
% App. Total	33.3	66.7	0		0	0	0		0	66.7	33.3			0	0	0		
PHF	.250	.250	.000	.375	.000	.000	.000	.000	.000	.000	.500	.375	.563	.000	.000	.000	.000	.500

Peak Hour Analysis From 07:00 AM to 07:45 AM - Peak 1 of 1

Peak Hour for Entire Intersection Begins at 07:00 AM

City of Fontana
 N/S: Sierra Avenue
 E/W: I-15 Northbound Ramps
 Weather: Clear

File Name : 05_FON_Sierra_15N AM
 Site Code : 12218022
 Start Date : 1/24/2018
 Page No : 2

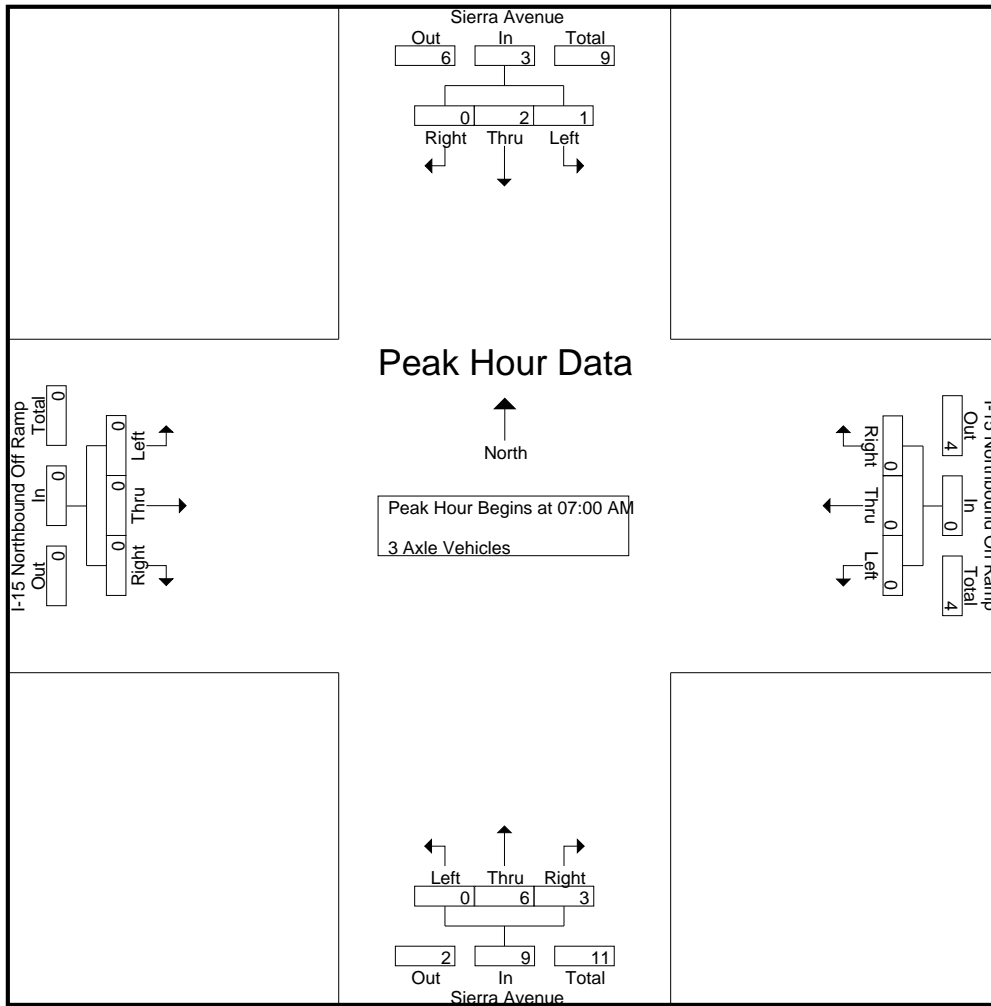

Peak Hour Analysis From 07:00 AM to 07:45 AM - Peak 1 of 1
 Peak Hour for Each Approach Begins at:

	07:00 AM				07:00 AM				07:00 AM				07:00 AM			
+0 mins.	0	0	0	0	0	0	0	0	0	1	0	1	0	0	0	0
+15 mins.	0	0	0	0	0	0	0	0	0	0	0	0	0	0	0	0
+30 mins.	1	0	0	1	0	0	0	0	0	3	1	4	0	0	0	0
+45 mins.	0	2	0	2	0	0	0	0	0	2	2	4	0	0	0	0
Total Volume	1	2	0	3	0	0	0	0	0	6	3	9	0	0	0	0
% App. Total	33.3	66.7	0		0	0	0		0	66.7	33.3		0	0	0	
PHF	.250	.250	.000	.375	.000	.000	.000	.000	.000	.500	.375	.563	.000	.000	.000	.000

City of Fontana
 N/S: Sierra Avenue
 E/W: I-15 Northbound Ramps
 Weather: Clear

File Name : 05_FON_Sierra_15N AM
 Site Code : 12218022
 Start Date : 1/24/2018
 Page No : 1

Groups Printed- 4+ Axle Trucks

Start Time	Sierra Avenue Southbound				I-15 Northbound On Ramp Westbound				Sierra Avenue Northbound				I-15 Northbound Off Ramp Eastbound				Int. Total
	Left	Thru	Right	App. Total	Left	Thru	Right	App. Total	Left	Thru	Right	App. Total	Left	Thru	Right	App. Total	
07:00 AM	0	4	0	4	0	0	0	0	0	0	3	3	0	0	4	4	11
07:15 AM	0	1	0	1	0	0	0	0	0	0	0	0	1	0	2	3	4
07:30 AM	0	1	0	1	0	0	0	0	0	2	2	4	1	0	2	3	8
07:45 AM	0	5	0	5	0	0	0	0	0	5	1	6	1	0	2	3	14
Total	0	11	0	11	0	0	0	0	0	7	6	13	3	0	10	13	37
08:00 AM	0	5	0	5	0	0	0	0	0	2	1	3	1	0	1	2	10
08:15 AM	0	2	0	2	0	0	0	0	0	1	2	3	1	0	2	3	8
08:30 AM	0	3	0	3	0	0	0	0	0	1	5	6	1	0	2	3	12
08:45 AM	0	4	0	4	0	0	0	0	0	3	1	4	0	1	1	2	10
Total	0	14	0	14	0	0	0	0	0	7	9	16	3	1	6	10	40
Grand Total	0	25	0	25	0	0	0	0	0	14	15	29	6	1	16	23	77
Apprch %	0	100	0		0	0	0		0	48.3	51.7		26.1	4.3	69.6		
Total %	0	32.5	0	32.5	0	0	0	0	0	18.2	19.5	37.7	7.8	1.3	20.8	29.9	

Start Time	Sierra Avenue Southbound				I-15 Northbound On Ramp Westbound				Sierra Avenue Northbound				I-15 Northbound Off Ramp Eastbound				Int. Total
	Left	Thru	Right	App. Total	Left	Thru	Right	App. Total	Left	Thru	Right	App. Total	Left	Thru	Right	App. Total	
07:00 AM	0	4	0	4	0	0	0	0	0	0	3	3	0	0	4	4	11
07:15 AM	0	1	0	1	0	0	0	0	0	0	0	0	1	0	2	3	4
07:30 AM	0	1	0	1	0	0	0	0	0	2	2	4	1	0	2	3	8
07:45 AM	0	5	0	5	0	0	0	0	0	5	1	6	1	0	2	3	14
Total Volume	0	11	0	11	0	0	0	0	0	7	6	13	3	0	10	13	37
% App. Total	0	100	0		0	0	0		0	53.8	46.2		23.1	0	76.9		
PHF	.000	.550	.000	.550	.000	.000	.000	.000	.000	.350	.500	.542	.750	.000	.625	.813	.661

Peak Hour Analysis From 07:00 AM to 07:45 AM - Peak 1 of 1

Peak Hour for Entire Intersection Begins at 07:00 AM

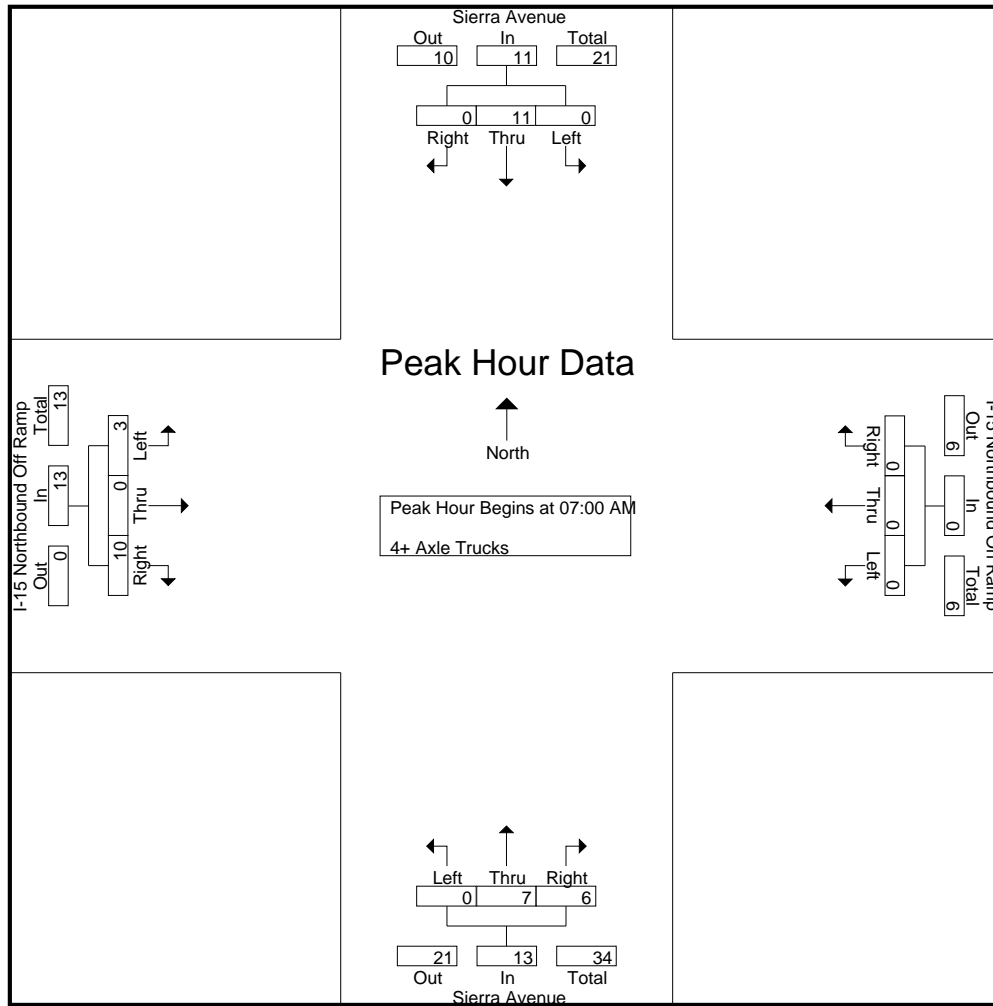

Peak Hour Analysis From 07:00 AM to 07:45 AM - Peak 1 of 1
 Peak Hour for Each Approach Begins at:

	07:00 AM				07:00 AM				07:00 AM				07:00 AM			
+0 mins.	0	4	0	4	0	0	0	0	0	0	3	3	0	0	4	4
+15 mins.	0	1	0	1	0	0	0	0	0	0	0	0	1	0	2	3
+30 mins.	0	1	0	1	0	0	0	0	0	2	2	4	1	0	2	3
+45 mins.	0	5	0	5	0	0	0	0	0	5	1	6	1	0	2	3
Total Volume	0	11	0	11	0	0	0	0	0	7	6	13	3	0	10	13
% App. Total	0	100	0		0	0	0	0	0	53.8	46.2		23.1	0	76.9	
PHF	.000	.550	.000	.550	.000	.000	.000	.000	.000	.350	.500	.542	.750	.000	.625	.813

City of Fontana
 N/S: Sierra Avenue
 E/W: I-15 Northbound Ramps
 Weather: Clear

File Name : 05_FON_Sierra_15N PM
 Site Code : 12218022
 Start Date : 1/24/2018
 Page No : 1

Groups Printed- Passenger Vehicles - Large 2 Axle Vehicles - 3 Axle Vehicles - 4+ Axle Trucks

Start Time	Sierra Avenue Southbound				I-15 Northbound On Ramp Westbound				Sierra Avenue Northbound				I-15 Northbound Off Ramp Eastbound				Int. Total
	Left	Thru	Right	App. Total	Left	Thru	Right	App. Total	Left	Thru	Right	App. Total	Left	Thru	Right	App. Total	
04:00 PM	34	166	0	200	0	0	0	0	0	86	111	197	100	1	83	184	581
04:15 PM	38	119	0	157	0	0	0	0	0	92	121	213	113	0	92	205	575
04:30 PM	30	95	0	125	0	0	0	0	0	108	124	232	138	0	81	219	576
04:45 PM	41	117	0	158	0	0	0	0	0	121	150	271	136	0	90	226	655
Total	143	497	0	640	0	0	0	0	0	407	506	913	487	1	346	834	2387
05:00 PM	41	113	0	154	0	0	0	0	0	101	112	213	133	0	98	231	598
05:15 PM	33	124	0	157	0	0	0	0	0	108	118	226	130	0	77	207	590
05:30 PM	31	115	0	146	0	0	0	0	0	94	101	195	141	0	73	214	555
05:45 PM	30	108	0	138	0	0	0	0	0	99	115	214	137	0	72	209	561
Total	135	460	0	595	0	0	0	0	0	402	446	848	541	0	320	861	2304
Grand Total	278	957	0	1235	0	0	0	0	0	809	952	1761	1028	1	666	1695	4691
Apprch %	22.5	77.5	0		0	0	0		0	45.9	54.1		60.6	0.1	39.3		
Total %	5.9	20.4	0	26.3	0	0	0	0	0	17.2	20.3	37.5	21.9	0	14.2	36.1	
Passenger Vehicles	271	923	0	1194	0	0	0	0	0	799	910	1709	1005	1	657	1663	4566
% Passenger Vehicles	97.5	96.4	0	96.7	0	0	0	0	0	98.8	95.6	97	97.8	100	98.6	98.1	97.3
Large 2 Axle Vehicles	3	10	0	13	0	0	0	0	0	5	10	15	11	0	1	12	40
% Large 2 Axle Vehicles	1.1	1	0	1.1	0	0	0	0	0	0.6	1.1	0.9	1.1	0	0.2	0.7	0.9
3 Axle Vehicles	0	2	0	2	0	0	0	0	0	0	2	2	0	0	3	3	7
% 3 Axle Vehicles	0	0.2	0	0.2	0	0	0	0	0	0	0.2	0.1	0	0	0.5	0.2	0.1
4+ Axle Trucks	4	22	0	26	0	0	0	0	0	5	30	35	12	0	5	17	78
% 4+ Axle Trucks	1.4	2.3	0	2.1	0	0	0	0	0	0.6	3.2	2	1.2	0	0.8	1	1.7

Start Time	Sierra Avenue Southbound				I-15 Northbound On Ramp Westbound				Sierra Avenue Northbound				I-15 Northbound Off Ramp Eastbound				Int. Total
	Left	Thru	Right	App. Total	Left	Thru	Right	App. Total	Left	Thru	Right	App. Total	Left	Thru	Right	App. Total	
Peak Hour Analysis From 04:00 PM to 05:45 PM - Peak 1 of 1																	
Peak Hour for Entire Intersection Begins at 04:30 PM																	
04:30 PM	30	95	0	125	0	0	0	0	0	108	124	232	138	0	81	219	576
04:45 PM	41	117	0	158	0	0	0	0	0	121	150	271	136	0	90	226	655
05:00 PM	41	113	0	154	0	0	0	0	0	101	112	213	133	0	98	231	598
05:15 PM	33	124	0	157	0	0	0	0	0	108	118	226	130	0	77	207	590
Total Volume	145	449	0	594	0	0	0	0	0	438	504	942	537	0	346	883	2419
% App. Total	24.4	75.6	0		0	0	0		0	46.5	53.5		60.8	0	39.2		
PHF	.884	.905	.000	.940	.000	.000	.000	.000	.000	.905	.840	.869	.973	.000	.883	.956	.923

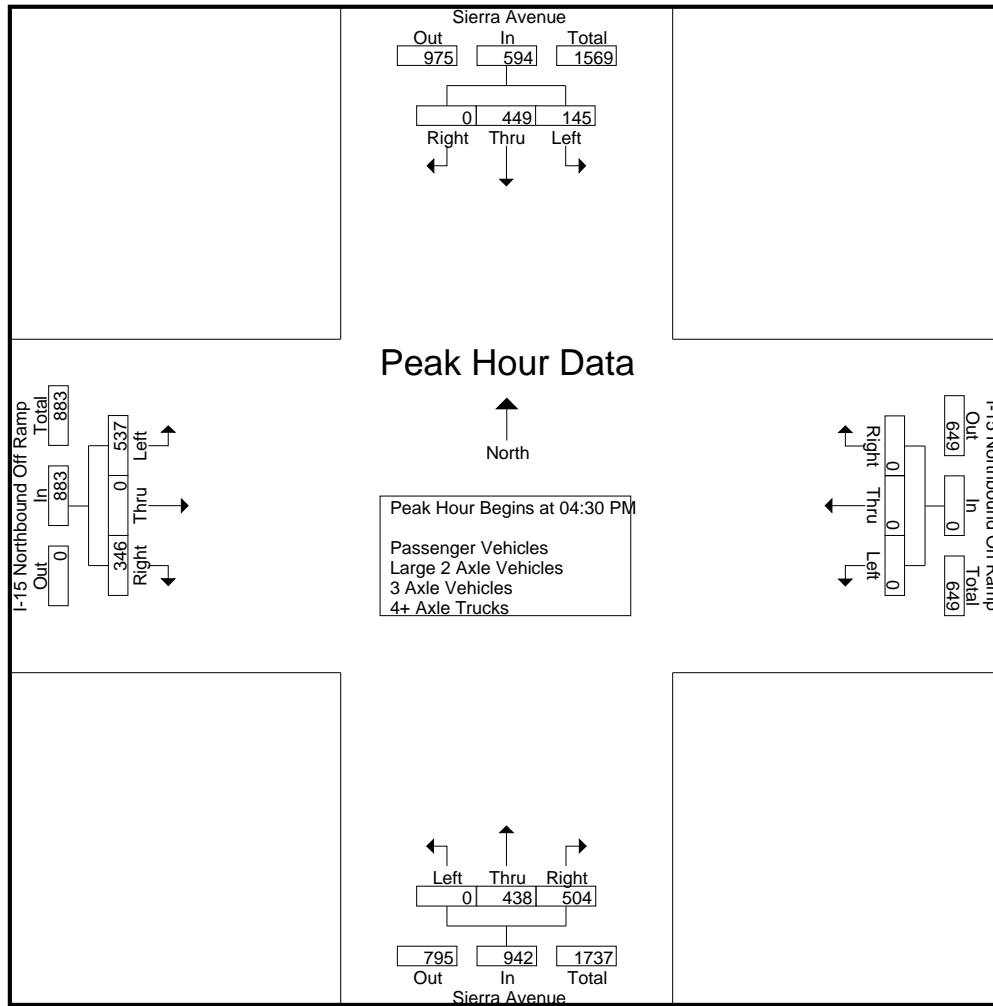

Peak Hour Analysis From 04:00 PM to 05:45 PM - Peak 1 of 1
 Peak Hour for Each Approach Begins at:

	04:00 PM				04:00 PM				04:30 PM				04:30 PM			
+0 mins.	34	166	0	200	0	0	0	0	0	108	124	232	138	0	81	219
+15 mins.	38	119	0	157	0	0	0	0	0	121	150	271	136	0	90	226
+30 mins.	30	95	0	125	0	0	0	0	0	101	112	213	133	0	98	231
+45 mins.	41	117	0	158	0	0	0	0	0	108	118	226	130	0	77	207
Total Volume	143	497	0	640	0	0	0	0	0	438	504	942	537	0	346	883
% App. Total	22.3	77.7	0		0	0	0		0	46.5	53.5		60.8	0	39.2	
PHF	.872	.748	.000	.800	.000	.000	.000	.000	.000	.905	.840	.869	.973	.000	.883	.956

City of Fontana
 N/S: Sierra Avenue
 E/W: I-15 Northbound Ramps
 Weather: Clear

File Name : 05_FON_Sierra_15N PM
 Site Code : 12218022
 Start Date : 1/24/2018
 Page No : 1

Groups Printed- Passenger Vehicles

Start Time	Sierra Avenue Southbound				I-15 Northbound On Ramp Westbound				Sierra Avenue Northbound				I-15 Northbound Off Ramp Eastbound				Int. Total
	Left	Thru	Right	App. Total	Left	Thru	Right	App. Total	Left	Thru	Right	App. Total	Left	Thru	Right	App. Total	
04:00 PM	33	162	0	195	0	0	0	0	0	84	104	188	97	1	81	179	562
04:15 PM	38	115	0	153	0	0	0	0	0	92	114	206	112	0	90	202	561
04:30 PM	29	90	0	119	0	0	0	0	0	106	119	225	134	0	79	213	557
04:45 PM	40	115	0	155	0	0	0	0	0	121	146	267	135	0	89	224	646
Total	140	482	0	622	0	0	0	0	0	403	483	886	478	1	339	818	2326
05:00 PM	39	111	0	150	0	0	0	0	0	100	106	206	131	0	96	227	583
05:15 PM	33	113	0	146	0	0	0	0	0	105	112	217	127	0	77	204	567
05:30 PM	29	112	0	141	0	0	0	0	0	94	97	191	136	0	73	209	541
05:45 PM	30	105	0	135	0	0	0	0	0	97	112	209	133	0	72	205	549
Total	131	441	0	572	0	0	0	0	0	396	427	823	527	0	318	845	2240
Grand Total	271	923	0	1194	0	0	0	0	0	799	910	1709	1005	1	657	1663	4566
Apprch %	22.7	77.3	0		0	0	0		0	46.8	53.2		60.4	0.1	39.5		
Total %	5.9	20.2	0	26.1	0	0	0	0	0	17.5	19.9	37.4	22	0	14.4	36.4	

Start Time	Sierra Avenue Southbound				I-15 Northbound On Ramp Westbound				Sierra Avenue Northbound				I-15 Northbound Off Ramp Eastbound				Int. Total
	Left	Thru	Right	App. Total	Left	Thru	Right	App. Total	Left	Thru	Right	App. Total	Left	Thru	Right	App. Total	
Peak Hour Analysis From 04:30 PM to 05:15 PM - Peak 1 of 1																	
Peak Hour for Entire Intersection Begins at 04:30 PM																	
04:30 PM	29	90	0	119	0	0	0	0	0	106	119	225	134	0	79	213	557
04:45 PM	40	115	0	155	0	0	0	0	0	121	146	267	135	0	89	224	646
05:00 PM	39	111	0	150	0	0	0	0	0	100	106	206	131	0	96	227	583
05:15 PM	33	113	0	146	0	0	0	0	0	105	112	217	127	0	77	204	567
Total Volume	141	429	0	570	0	0	0	0	0	432	483	915	527	0	341	868	2353
% App. Total	24.7	75.3	0		0	0	0		0	47.2	52.8		60.7	0	39.3		
PHF	.881	.933	.000	.919	.000	.000	.000	.000	.000	.893	.827	.857	.976	.000	.888	.956	.911

City of Fontana
 N/S: Sierra Avenue
 E/W: I-15 Northbound Ramps
 Weather: Clear

File Name : 05_FON_Sierra_15N PM
 Site Code : 12218022
 Start Date : 1/24/2018
 Page No : 2

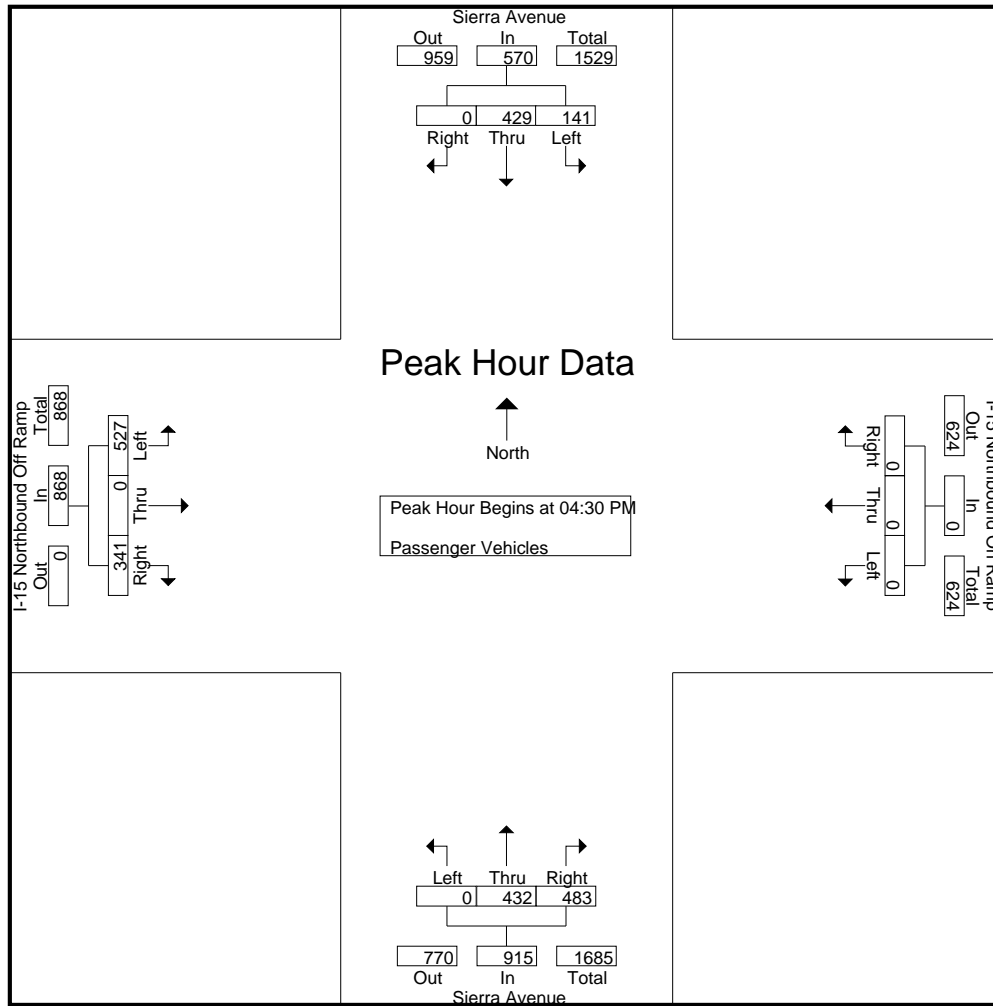

Peak Hour Analysis From 04:30 PM to 05:15 PM - Peak 1 of 1
 Peak Hour for Each Approach Begins at:

	04:30 PM				04:30 PM				04:30 PM				04:30 PM			
+0 mins.	29	90	0	119	0	0	0	0	0	106	119	225	134	0	79	213
+15 mins.	40	115	0	155	0	0	0	0	0	121	146	267	135	0	89	224
+30 mins.	39	111	0	150	0	0	0	0	0	100	106	206	131	0	96	227
+45 mins.	33	113	0	146	0	0	0	0	0	105	112	217	127	0	77	204
Total Volume	141	429	0	570	0	0	0	0	0	432	483	915	527	0	341	868
% App. Total	24.7	75.3	0		0	0	0		0	47.2	52.8		60.7	0	39.3	
PHF	.881	.933	.000	.919	.000	.000	.000	.000	.000	.893	.827	.857	.976	.000	.888	.956

City of Fontana
 N/S: Sierra Avenue
 E/W: I-15 Northbound Ramps
 Weather: Clear

File Name : 05_FON_Sierra_15N PM
 Site Code : 12218022
 Start Date : 1/24/2018
 Page No : 1

Groups Printed- Large 2 Axle Vehicles

Start Time	Sierra Avenue Southbound				I-15 Northbound On Ramp Westbound				Sierra Avenue Northbound				I-15 Northbound Off Ramp Eastbound				Int. Total
	Left	Thru	Right	App. Total	Left	Thru	Right	App. Total	Left	Thru	Right	App. Total	Left	Thru	Right	App. Total	
04:00 PM	0	2	0	2	0	0	0	0	0	1	2	3	0	0	0	0	5
04:15 PM	0	1	0	1	0	0	0	0	0	0	1	1	0	0	0	0	2
04:30 PM	0	2	0	2	0	0	0	0	0	1	1	2	3	0	1	4	8
04:45 PM	0	0	0	0	0	0	0	0	0	0	0	0	1	0	0	1	1
Total	0	5	0	5	0	0	0	0	0	2	4	6	4	0	1	5	16
05:00 PM	2	2	0	4	0	0	0	0	0	0	2	2	0	0	0	0	6
05:15 PM	0	3	0	3	0	0	0	0	0	2	2	4	1	0	0	1	8
05:30 PM	1	0	0	1	0	0	0	0	0	0	0	0	3	0	0	3	4
05:45 PM	0	0	0	0	0	0	0	0	0	1	2	3	3	0	0	3	6
Total	3	5	0	8	0	0	0	0	0	3	6	9	7	0	0	7	24
Grand Total	3	10	0	13	0	0	0	0	0	5	10	15	11	0	1	12	40
Apprch %	23.1	76.9	0		0	0	0		0	33.3	66.7		91.7	0	8.3		
Total %	7.5	25	0	32.5	0	0	0	0	0	12.5	25	37.5	27.5	0	2.5	30	

Start Time	Sierra Avenue Southbound				I-15 Northbound On Ramp Westbound				Sierra Avenue Northbound				I-15 Northbound Off Ramp Eastbound				Int. Total
	Left	Thru	Right	App. Total	Left	Thru	Right	App. Total	Left	Thru	Right	App. Total	Left	Thru	Right	App. Total	
Peak Hour Analysis From 04:30 PM to 05:15 PM - Peak 1 of 1																	
Peak Hour for Entire Intersection Begins at 04:30 PM																	
04:30 PM	0	2	0	2	0	0	0	0	0	1	1	2	3	0	1	4	8
04:45 PM	0	0	0	0	0	0	0	0	0	0	0	0	1	0	0	1	1
05:00 PM	2	2	0	4	0	0	0	0	0	0	2	2	0	0	0	0	6
05:15 PM	0	3	0	3	0	0	0	0	0	2	2	4	1	0	0	1	8
Total Volume	2	7	0	9	0	0	0	0	0	3	5	8	5	0	1	6	23
% App. Total	22.2	77.8	0		0	0	0		0	37.5	62.5		83.3	0	16.7		
PHF	.250	.583	.000	.563	.000	.000	.000	.000	.000	.375	.625	.500	.417	.000	.250	.375	.719

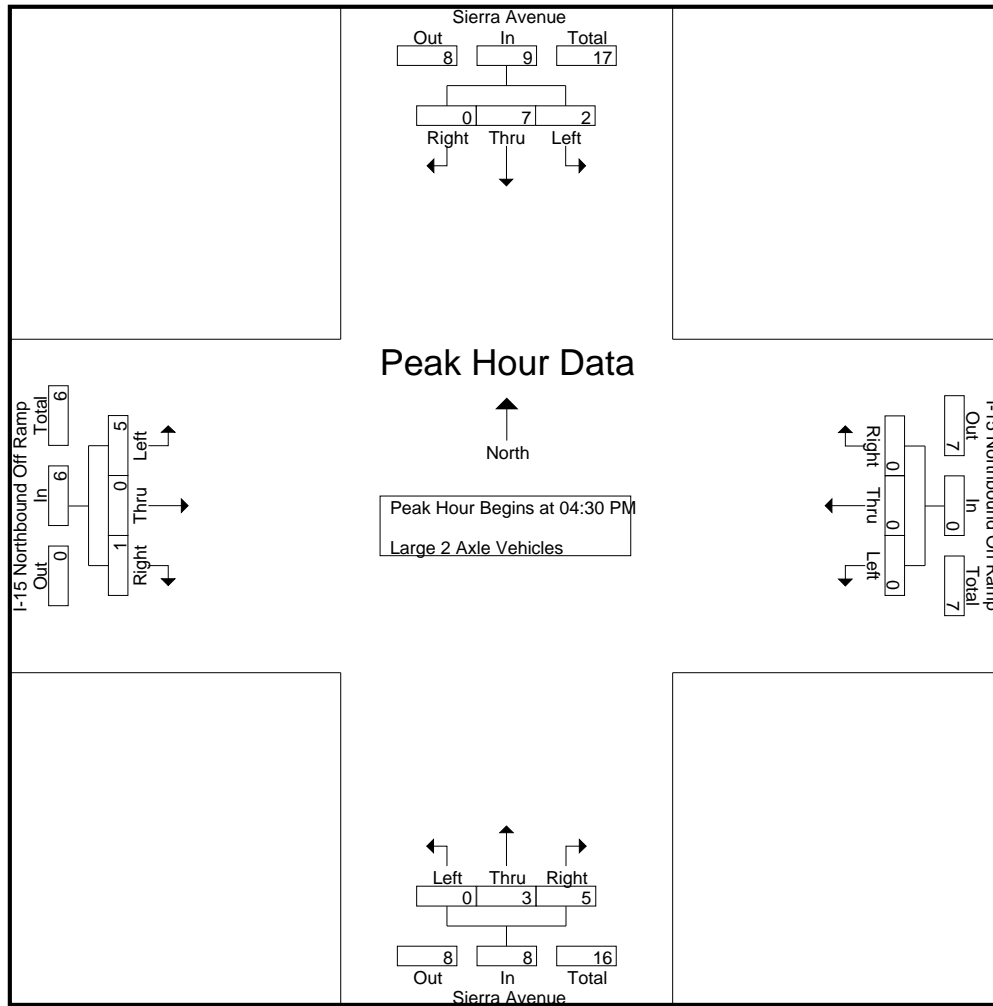

Peak Hour Analysis From 04:30 PM to 05:15 PM - Peak 1 of 1
 Peak Hour for Each Approach Begins at:

	04:30 PM				04:30 PM				04:30 PM				04:30 PM			
+0 mins.	0	2	0	2	0	0	0	0	0	1	1	2	3	0	1	4
+15 mins.	0	0	0	0	0	0	0	0	0	0	0	0	1	0	0	1
+30 mins.	2	2	0	4	0	0	0	0	0	0	2	2	0	0	0	0
+45 mins.	0	3	0	3	0	0	0	0	0	2	2	4	1	0	0	1
Total Volume	2	7	0	9	0	0	0	0	0	3	5	8	5	0	1	6
% App. Total	22.2	77.8	0		0	0	0	0	0	37.5	62.5		83.3	0	16.7	
PHF	.250	.583	.000	.563	.000	.000	.000	.000	.000	.375	.625	.500	.417	.000	.250	.375

City of Fontana
 N/S: Sierra Avenue
 E/W: I-15 Northbound Ramps
 Weather: Clear

File Name : 05_FON_Sierra_15N PM
 Site Code : 12218022
 Start Date : 1/24/2018
 Page No : 1

Groups Printed- 3 Axle Vehicles

Start Time	Sierra Avenue Southbound				I-15 Northbound On Ramp Westbound				Sierra Avenue Northbound				I-15 Northbound Off Ramp Eastbound				Int. Total	
	Left	Thru	Right	App. Total	Left	Thru	Right	App. Total	Left	Thru	Right	App. Total	Left	Thru	Right	App. Total		
04:00 PM	0	1	0	1	0	0	0	0	0	0	0	0	0	0	0	0	0	1
04:15 PM	0	0	0	0	0	0	0	0	0	0	0	0	0	0	1	0	0	1
04:30 PM	0	1	0	1	0	0	0	0	0	0	0	0	0	0	0	0	0	1
04:45 PM	0	0	0	0	0	0	0	0	0	0	0	0	0	0	1	0	0	1
Total	0	2	0	2	0	0	0	0	0	0	0	0	0	0	2	0	0	4
05:00 PM	0	0	0	0	0	0	0	0	0	0	0	0	0	0	1	0	0	1
05:15 PM	0	0	0	0	0	0	0	0	0	0	2	2	0	0	0	0	0	2
05:30 PM	0	0	0	0	0	0	0	0	0	0	0	0	0	0	0	0	0	0
05:45 PM	0	0	0	0	0	0	0	0	0	0	0	0	0	0	0	0	0	0
Total	0	0	0	0	0	0	0	0	0	0	2	2	0	0	1	0	0	3
Grand Total	0	2	0	2	0	0	0	0	0	0	2	2	0	0	3	0	0	7
Apprch %	0	100	0		0	0	0		0	0	100		0	0	100			
Total %	0	28.6	0	28.6	0	0	0	0	0	0	28.6	28.6	0	0	42.9	0	0	42.9

Start Time	Sierra Avenue Southbound				I-15 Northbound On Ramp Westbound				Sierra Avenue Northbound				I-15 Northbound Off Ramp Eastbound				Int. Total	
	Left	Thru	Right	App. Total	Left	Thru	Right	App. Total	Left	Thru	Right	App. Total	Left	Thru	Right	App. Total		
04:30 PM	0	1	0	1	0	0	0	0	0	0	0	0	0	0	0	0	0	1
04:45 PM	0	0	0	0	0	0	0	0	0	0	0	0	0	0	1	0	0	1
05:00 PM	0	0	0	0	0	0	0	0	0	0	0	0	0	0	1	0	0	1
05:15 PM	0	0	0	0	0	0	0	0	0	0	2	2	0	0	0	0	0	2
Total Volume	0	1	0	1	0	0	0	0	0	0	2	2	0	0	2	0	0	5
% App. Total	0	100	0		0	0	0		0	0	100		0	0	100			
PHF	.000	.250	.000	.250	.000	.000	.000	.000	.000	.000	.250	.250	.000	.000	.500	.500		.625

Peak Hour Analysis From 04:30 PM to 05:15 PM - Peak 1 of 1

Peak Hour for Entire Intersection Begins at 04:30 PM

City of Fontana
 N/S: Sierra Avenue
 E/W: I-15 Northbound Ramps
 Weather: Clear

File Name : 05_FON_Sierra_15N PM
 Site Code : 12218022
 Start Date : 1/24/2018
 Page No : 2

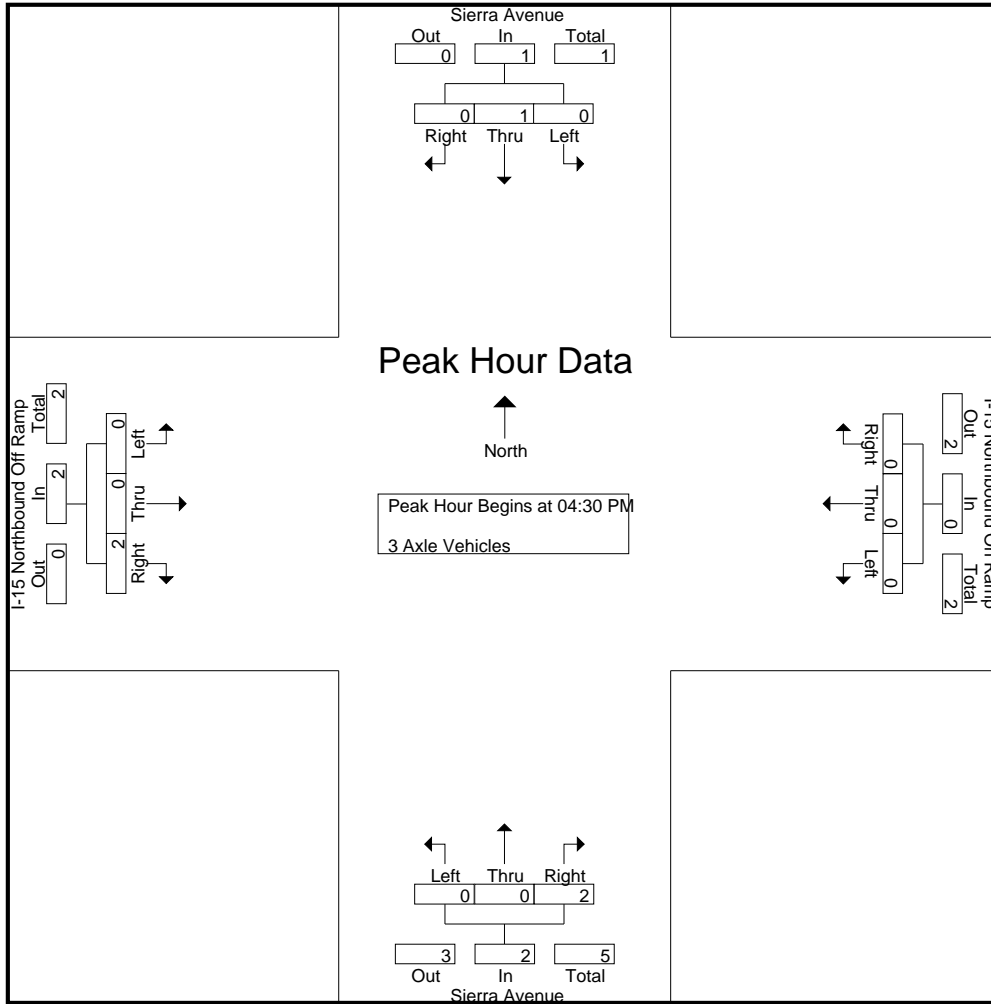

Peak Hour Analysis From 04:30 PM to 05:15 PM - Peak 1 of 1
 Peak Hour for Each Approach Begins at:

	04:30 PM				04:30 PM				04:30 PM				04:30 PM			
+0 mins.	0	1	0	1	0	0	0	0	0	0	0	0	0	0	0	0
+15 mins.	0	0	0	0	0	0	0	0	0	0	0	0	0	0	0	1
+30 mins.	0	0	0	0	0	0	0	0	0	0	0	0	0	0	1	1
+45 mins.	0	0	0	0	0	0	0	0	0	0	2	2	0	0	0	0
Total Volume	0	1	0	1	0	0	0	0	0	0	2	2	0	0	2	2
% App. Total	0	100	0	100	0	0	0	0	0	0	100	100	0	0	100	100
PHF	.000	.250	.000	.250	.000	.000	.000	.000	.000	.000	.250	.250	.000	.000	.500	.500

City of Fontana
 N/S: Sierra Avenue
 E/W: I-15 Northbound Ramps
 Weather: Clear

File Name : 05_FON_Sierra_15N PM
 Site Code : 12218022
 Start Date : 1/24/2018
 Page No : 1

Groups Printed- 4+ Axle Trucks

Start Time	Sierra Avenue Southbound				I-15 Northbound On Ramp Westbound				Sierra Avenue Northbound				I-15 Northbound Off Ramp Eastbound				Int. Total
	Left	Thru	Right	App. Total	Left	Thru	Right	App. Total	Left	Thru	Right	App. Total	Left	Thru	Right	App. Total	
04:00 PM	1	1	0	2	0	0	0	0	0	1	5	6	3	0	2	5	13
04:15 PM	0	3	0	3	0	0	0	0	0	0	6	6	1	0	1	2	11
04:30 PM	1	2	0	3	0	0	0	0	0	1	4	5	1	0	1	2	10
04:45 PM	1	2	0	3	0	0	0	0	0	0	4	4	0	0	0	0	7
Total	3	8	0	11	0	0	0	0	0	2	19	21	5	0	4	9	41
05:00 PM	0	0	0	0	0	0	0	0	0	1	4	5	2	0	1	3	8
05:15 PM	0	8	0	8	0	0	0	0	0	1	2	3	2	0	0	2	13
05:30 PM	1	3	0	4	0	0	0	0	0	0	4	4	2	0	0	2	10
05:45 PM	0	3	0	3	0	0	0	0	0	1	1	2	1	0	0	1	6
Total	1	14	0	15	0	0	0	0	0	3	11	14	7	0	1	8	37
Grand Total	4	22	0	26	0	0	0	0	0	5	30	35	12	0	5	17	78
Apprch %	15.4	84.6	0		0	0	0		0	14.3	85.7		70.6	0	29.4		
Total %	5.1	28.2	0	33.3	0	0	0	0	0	6.4	38.5	44.9	15.4	0	6.4	21.8	

Start Time	Sierra Avenue Southbound				I-15 Northbound On Ramp Westbound				Sierra Avenue Northbound				I-15 Northbound Off Ramp Eastbound				Int. Total
	Left	Thru	Right	App. Total	Left	Thru	Right	App. Total	Left	Thru	Right	App. Total	Left	Thru	Right	App. Total	
Peak Hour Analysis From 04:30 PM to 05:15 PM - Peak 1 of 1																	
Peak Hour for Entire Intersection Begins at 04:30 PM																	
04:30 PM	1	2	0	3	0	0	0	0	0	1	4	5	1	0	1	2	10
04:45 PM	1	2	0	3	0	0	0	0	0	0	4	4	0	0	0	0	7
05:00 PM	0	0	0	0	0	0	0	0	0	1	4	5	2	0	1	3	8
05:15 PM	0	8	0	8	0	0	0	0	0	1	2	3	2	0	0	2	13
Total Volume	2	12	0	14	0	0	0	0	0	3	14	17	5	0	2	7	38
% App. Total	14.3	85.7	0		0	0	0		0	17.6	82.4		71.4	0	28.6		
PHF	.500	.375	.000	.438	.000	.000	.000	.000	.000	.750	.875	.850	.625	.000	.500	.583	.731

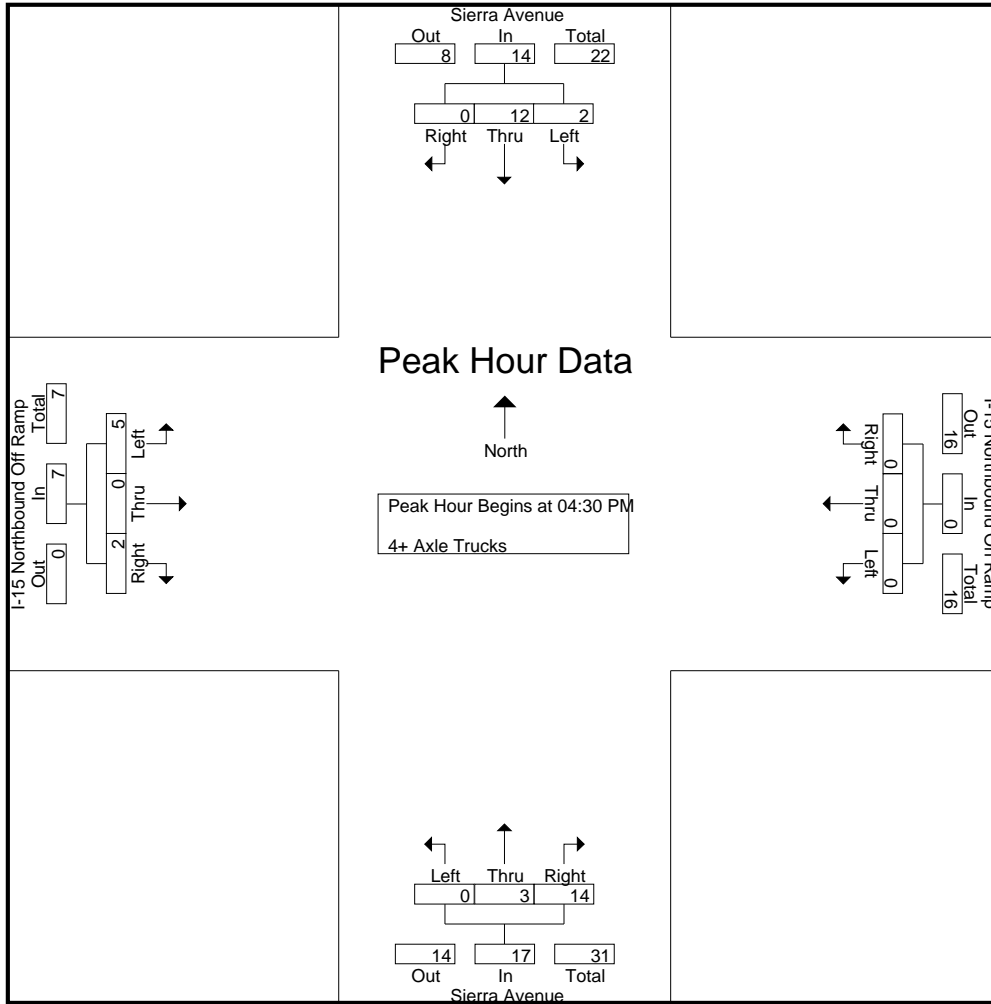

Peak Hour Analysis From 04:30 PM to 05:15 PM - Peak 1 of 1
 Peak Hour for Each Approach Begins at:

	04:30 PM				04:30 PM				04:30 PM				04:30 PM			
+0 mins.	1	2	0	3	0	0	0	0	0	1	4	5	1	0	1	2
+15 mins.	1	2	0	3	0	0	0	0	0	0	4	4	0	0	0	0
+30 mins.	0	0	0	0	0	0	0	0	0	1	4	5	2	0	1	3
+45 mins.	0	8	0	8	0	0	0	0	0	1	2	3	2	0	0	2
Total Volume	2	12	0	14	0	0	0	0	0	3	14	17	5	0	2	7
% App. Total	14.3	85.7	0		0	0	0	0	0	17.6	82.4		71.4	0	28.6	
PHF	.500	.375	.000	.438	.000	.000	.000	.000	.000	.750	.875	.850	.625	.000	.500	.583

City of Fontana
 N/S: Sierra Avenue
 E/W: Riverside Avenue
 Weather: Clear

File Name : 06_FON_Sierra_Riverside AM
 Site Code : 12218022
 Start Date : 1/24/2018
 Page No : 1

Groups Printed- Passenger Vehicles - Large 2 Axle Vehicles - 3 Axle Vehicles - 4+ Axle Trucks

Start Time	Sierra Avenue Southbound			Riverside Avenue Westbound			Sierra Avenue Northbound			Int. Total
	Left	Thru	App. Total	Left	Right	App. Total	Thru	Right	App. Total	
07:00 AM	93	99	192	8	115	123	66	1	67	382
07:15 AM	76	143	219	10	132	142	87	6	93	454
07:30 AM	94	161	255	12	107	119	77	8	85	459
07:45 AM	93	109	202	10	88	98	66	19	85	385
Total	356	512	868	40	442	482	296	34	330	1680
08:00 AM	65	122	187	8	81	89	78	7	85	361
08:15 AM	72	104	176	3	70	73	55	1	56	305
08:30 AM	63	102	165	2	63	65	56	4	60	290
08:45 AM	49	113	162	3	49	52	56	0	56	270
Total	249	441	690	16	263	279	245	12	257	1226
Grand Total	605	953	1558	56	705	761	541	46	587	2906
Apprch %	38.8	61.2		7.4	92.6		92.2	7.8		
Total %	20.8	32.8	53.6	1.9	24.3	26.2	18.6	1.6	20.2	
Passenger Vehicles	555	927	1482	54	666	720	512	41	553	2755
% Passenger Vehicles	91.7	97.3	95.1	96.4	94.5	94.6	94.6	89.1	94.2	94.8
Large 2 Axle Vehicles	15	9	24	2	11	13	13	4	17	54
% Large 2 Axle Vehicles	2.5	0.9	1.5	3.6	1.6	1.7	2.4	8.7	2.9	1.9
3 Axle Vehicles	3	6	9	0	3	3	10	1	11	23
% 3 Axle Vehicles	0.5	0.6	0.6	0	0.4	0.4	1.8	2.2	1.9	0.8
4+ Axle Trucks	32	11	43	0	25	25	6	0	6	74
% 4+ Axle Trucks	5.3	1.2	2.8	0	3.5	3.3	1.1	0	1	2.5

Start Time	Sierra Avenue Southbound			Riverside Avenue Westbound			Sierra Avenue Northbound			Int. Total
	Left	Thru	App. Total	Left	Right	App. Total	Thru	Right	App. Total	
07:00 AM	93	99	192	8	115	123	66	1	67	382
07:15 AM	76	143	219	10	132	142	87	6	93	454
07:30 AM	94	161	255	12	107	119	77	8	85	459
07:45 AM	93	109	202	10	88	98	66	19	85	385
Total Volume	356	512	868	40	442	482	296	34	330	1680
% App. Total	41	59		8.3	91.7		89.7	10.3		
PHF	.947	.795	.851	.833	.837	.849	.851	.447	.887	.915

Peak Hour Analysis From 07:00 AM to 08:45 AM - Peak 1 of 1
 Peak Hour for Entire Intersection Begins at 07:00 AM

City of Fontana
 N/S: Sierra Avenue
 E/W: Riverside Avenue
 Weather: Clear

File Name : 06_FON_Sierra_Riverside AM
 Site Code : 12218022
 Start Date : 1/24/2018
 Page No : 2

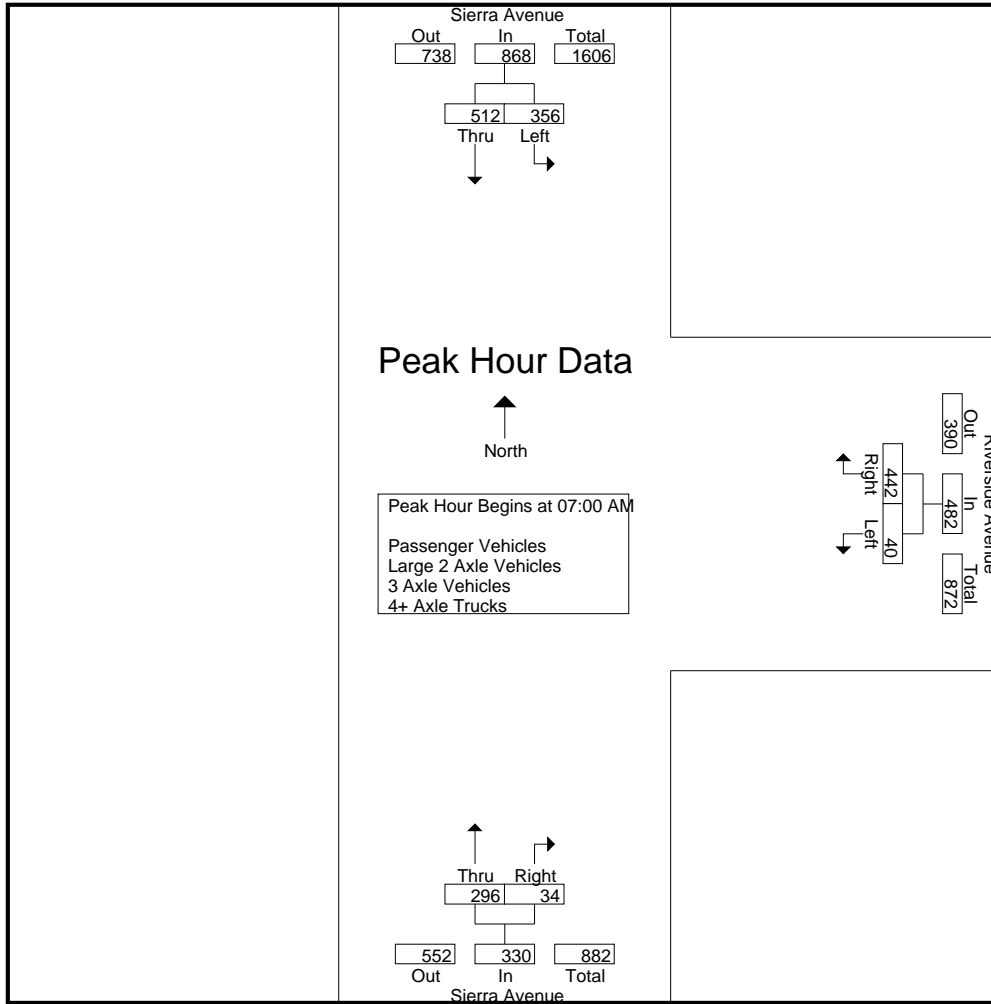

Peak Hour Analysis From 07:00 AM to 08:45 AM - Peak 1 of 1
 Peak Hour for Each Approach Begins at:

	07:00 AM			07:00 AM			07:15 AM		
+0 mins.	93	99	192	8	115	123	87	6	93
+15 mins.	76	143	219	10	132	142	77	8	85
+30 mins.	94	161	255	12	107	119	66	19	85
+45 mins.	93	109	202	10	88	98	78	7	85
Total Volume	356	512	868	40	442	482	308	40	348
% App. Total	41	59		8.3	91.7		88.5	11.5	
PHF	.947	.795	.851	.833	.837	.849	.885	.526	.935

City of Fontana
 N/S: Sierra Avenue
 E/W: Riverside Avenue
 Weather: Clear

File Name : 06_FON_Sierra_Riverside AM
 Site Code : 12218022
 Start Date : 1/24/2018
 Page No : 1

Groups Printed- Passenger Vehicles

Start Time	Sierra Avenue Southbound			Riverside Avenue Westbound			Sierra Avenue Northbound			Int. Total
	Left	Thru	App. Total	Left	Right	App. Total	Thru	Right	App. Total	
07:00 AM	80	99	179	8	112	120	64	1	65	364
07:15 AM	71	142	213	8	131	139	84	5	89	441
07:30 AM	89	160	249	12	99	111	71	6	77	437
07:45 AM	86	101	187	10	79	89	62	18	80	356
Total	326	502	828	38	421	459	281	30	311	1598
08:00 AM	59	119	178	8	78	86	75	6	81	345
08:15 AM	65	100	165	3	68	71	51	1	52	288
08:30 AM	58	99	157	2	58	60	52	4	56	273
08:45 AM	47	107	154	3	41	44	53	0	53	251
Total	229	425	654	16	245	261	231	11	242	1157
Grand Total	555	927	1482	54	666	720	512	41	553	2755
Apprch %	37.4	62.6		7.5	92.5		92.6	7.4		
Total %	20.1	33.6	53.8	2	24.2	26.1	18.6	1.5	20.1	

Start Time	Sierra Avenue Southbound			Riverside Avenue Westbound			Sierra Avenue Northbound			Int. Total
	Left	Thru	App. Total	Left	Right	App. Total	Thru	Right	App. Total	
07:00 AM	80	99	179	8	112	120	64	1	65	364
07:15 AM	71	142	213	8	131	139	84	5	89	441
07:30 AM	89	160	249	12	99	111	71	6	77	437
07:45 AM	86	101	187	10	79	89	62	18	80	356
Total Volume	326	502	828	38	421	459	281	30	311	1598
% App. Total	39.4	60.6		8.3	91.7		90.4	9.6		
PHF	.916	.784	.831	.792	.803	.826	.836	.417	.874	.906

Peak Hour Analysis From 07:00 AM to 07:45 AM - Peak 1 of 1
 Peak Hour for Entire Intersection Begins at 07:00 AM

City of Fontana
 N/S: Sierra Avenue
 E/W: Riverside Avenue
 Weather: Clear

File Name : 06_FON_Sierra_Riverside AM
 Site Code : 12218022
 Start Date : 1/24/2018
 Page No : 2

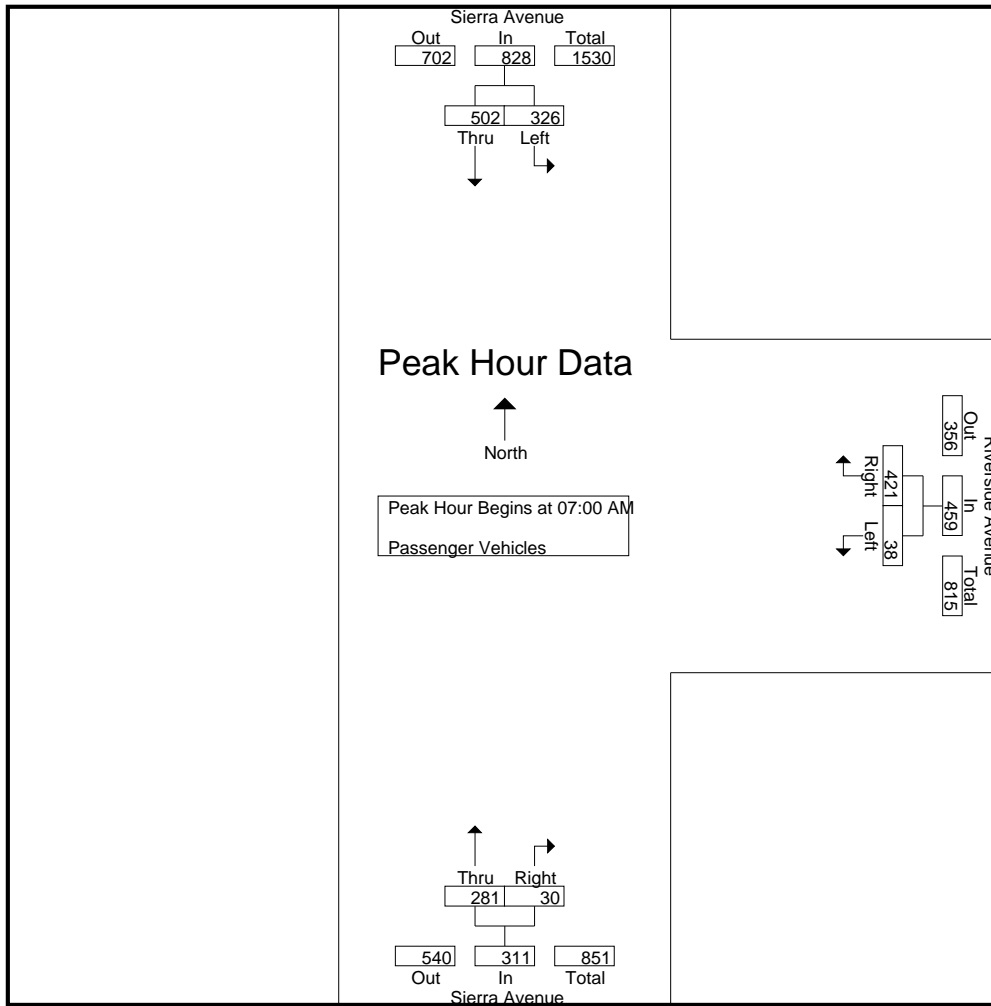

Peak Hour Analysis From 07:00 AM to 07:45 AM - Peak 1 of 1
 Peak Hour for Each Approach Begins at:

	07:00 AM			07:00 AM			07:00 AM		
+0 mins.	80	99	179	8	112	120	64	1	65
+15 mins.	71	142	213	8	131	139	84	5	89
+30 mins.	89	160	249	12	99	111	71	6	77
+45 mins.	86	101	187	10	79	89	62	18	80
Total Volume	326	502	828	38	421	459	281	30	311
% App. Total	39.4	60.6		8.3	91.7		90.4	9.6	
PHF	.916	.784	.831	.792	.803	.826	.836	.417	.874

City of Fontana
 N/S: Sierra Avenue
 E/W: Riverside Avenue
 Weather: Clear

File Name : 06_FON_Sierra_Riverside AM
 Site Code : 12218022
 Start Date : 1/24/2018
 Page No : 1

Groups Printed- Large 2 Axle Vehicles

Start Time	Sierra Avenue Southbound			Riverside Avenue Westbound			Sierra Avenue Northbound			Int. Total
	Left	Thru	App. Total	Left	Right	App. Total	Thru	Right	App. Total	
07:00 AM	5	0	5	0	1	1	1	0	1	7
07:15 AM	2	1	3	2	1	3	2	1	3	9
07:30 AM	2	1	3	0	3	3	3	2	5	11
07:45 AM	4	1	5	0	1	1	1	1	2	8
Total	13	3	16	2	6	8	7	4	11	35
08:00 AM	1	3	4	0	1	1	1	0	1	6
08:15 AM	1	1	2	0	0	0	1	0	1	3
08:30 AM	0	1	1	0	1	1	1	0	1	3
08:45 AM	0	1	1	0	3	3	3	0	3	7
Total	2	6	8	0	5	5	6	0	6	19
Grand Total	15	9	24	2	11	13	13	4	17	54
Apprch %	62.5	37.5		15.4	84.6		76.5	23.5		
Total %	27.8	16.7	44.4	3.7	20.4	24.1	24.1	7.4	31.5	

Start Time	Sierra Avenue Southbound			Riverside Avenue Westbound			Sierra Avenue Northbound			Int. Total
	Left	Thru	App. Total	Left	Right	App. Total	Thru	Right	App. Total	
07:00 AM	5	0	5	0	1	1	1	0	1	7
07:15 AM	2	1	3	2	1	3	2	1	3	9
07:30 AM	2	1	3	0	3	3	3	2	5	11
07:45 AM	4	1	5	0	1	1	1	1	2	8
Total Volume	13	3	16	2	6	8	7	4	11	35
% App. Total	81.2	18.8		25	75		63.6	36.4		
PHF	.650	.750	.800	.250	.500	.667	.583	.500	.550	.795

Peak Hour Analysis From 07:00 AM to 07:45 AM - Peak 1 of 1
 Peak Hour for Entire Intersection Begins at 07:00 AM

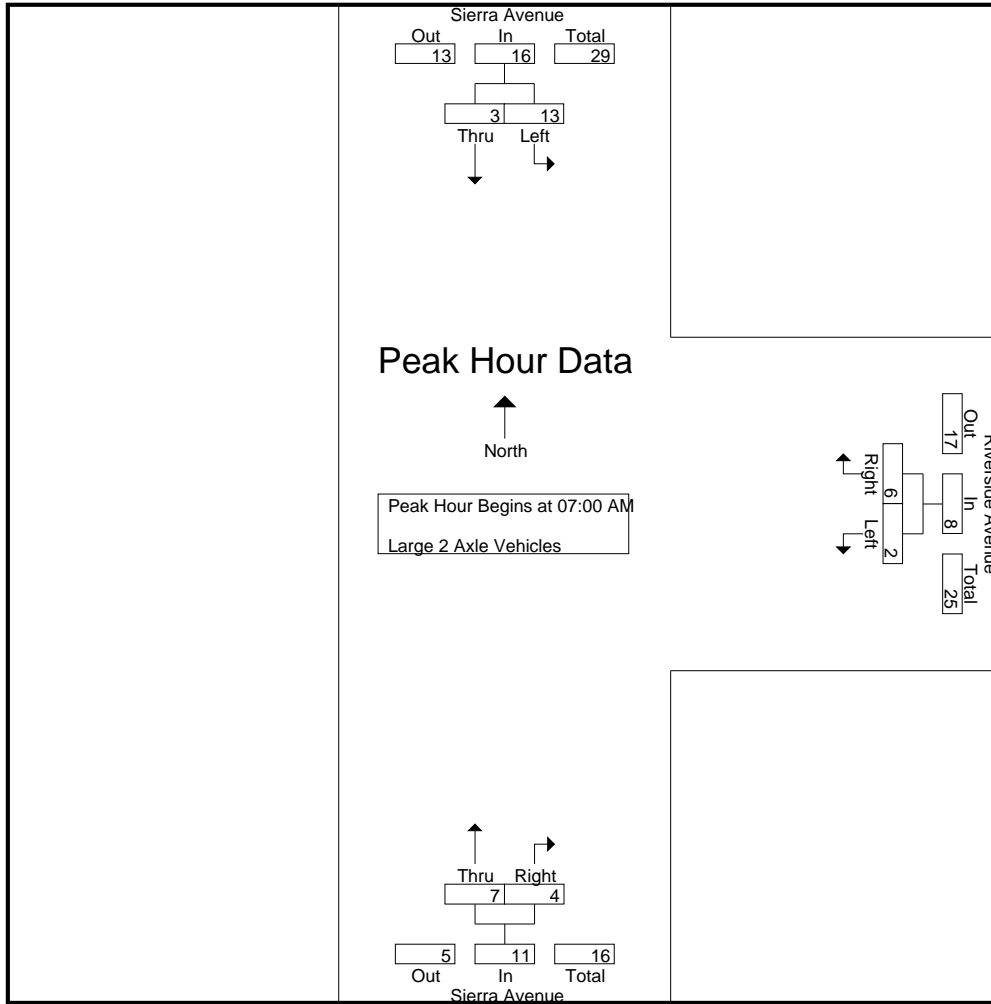

Peak Hour Analysis From 07:00 AM to 07:45 AM - Peak 1 of 1
 Peak Hour for Each Approach Begins at:

	07:00 AM			07:00 AM			07:00 AM		
+0 mins.	5	0	5	0	1	1	1	0	1
+15 mins.	2	1	3	2	1	3	2	1	3
+30 mins.	2	1	3	0	3	3	3	2	5
+45 mins.	4	1	5	0	1	1	1	1	2
Total Volume	13	3	16	2	6	8	7	4	11
% App. Total	81.2	18.8		25	75		63.6	36.4	
PHF	.650	.750	.800	.250	.500	.667	.583	.500	.550

City of Fontana
 N/S: Sierra Avenue
 E/W: Riverside Avenue
 Weather: Clear

File Name : 06_FON_Sierra_Riverside AM
 Site Code : 12218022
 Start Date : 1/24/2018
 Page No : 1

Groups Printed- 3 Axle Vehicles

Start Time	Sierra Avenue Southbound			Riverside Avenue Westbound			Sierra Avenue Northbound			Int. Total
	Left	Thru	App. Total	Left	Right	App. Total	Thru	Right	App. Total	
07:00 AM	0	0	0	0	0	0	1	0	1	1
07:15 AM	0	0	0	0	0	0	1	0	1	1
07:30 AM	0	0	0	0	1	1	2	0	2	3
07:45 AM	0	2	2	0	1	1	3	0	3	6
Total	0	2	2	0	2	2	7	0	7	11
08:00 AM	0	0	0	0	0	0	1	1	2	2
08:15 AM	2	2	4	0	1	1	1	0	1	6
08:30 AM	1	1	2	0	0	0	1	0	1	3
08:45 AM	0	1	1	0	0	0	0	0	0	1
Total	3	4	7	0	1	1	3	1	4	12
Grand Total	3	6	9	0	3	3	10	1	11	23
Apprch %	33.3	66.7		0	100		90.9	9.1		
Total %	13	26.1	39.1	0	13	13	43.5	4.3	47.8	

Start Time	Sierra Avenue Southbound			Riverside Avenue Westbound			Sierra Avenue Northbound			Int. Total
	Left	Thru	App. Total	Left	Right	App. Total	Thru	Right	App. Total	
07:00 AM	0	0	0	0	0	0	1	0	1	1
07:15 AM	0	0	0	0	0	0	1	0	1	1
07:30 AM	0	0	0	0	1	1	2	0	2	3
07:45 AM	0	2	2	0	1	1	3	0	3	6
Total Volume	0	2	2	0	2	2	7	0	7	11
% App. Total	0	100		0	100		100	0		
PHF	.000	.250	.250	.000	.500	.500	.583	.000	.583	.458

Peak Hour Analysis From 07:00 AM to 07:45 AM - Peak 1 of 1
 Peak Hour for Entire Intersection Begins at 07:00 AM

City of Fontana
 N/S: Sierra Avenue
 E/W: Riverside Avenue
 Weather: Clear

File Name : 06_FON_Sierra_Riverside AM
 Site Code : 12218022
 Start Date : 1/24/2018
 Page No : 2

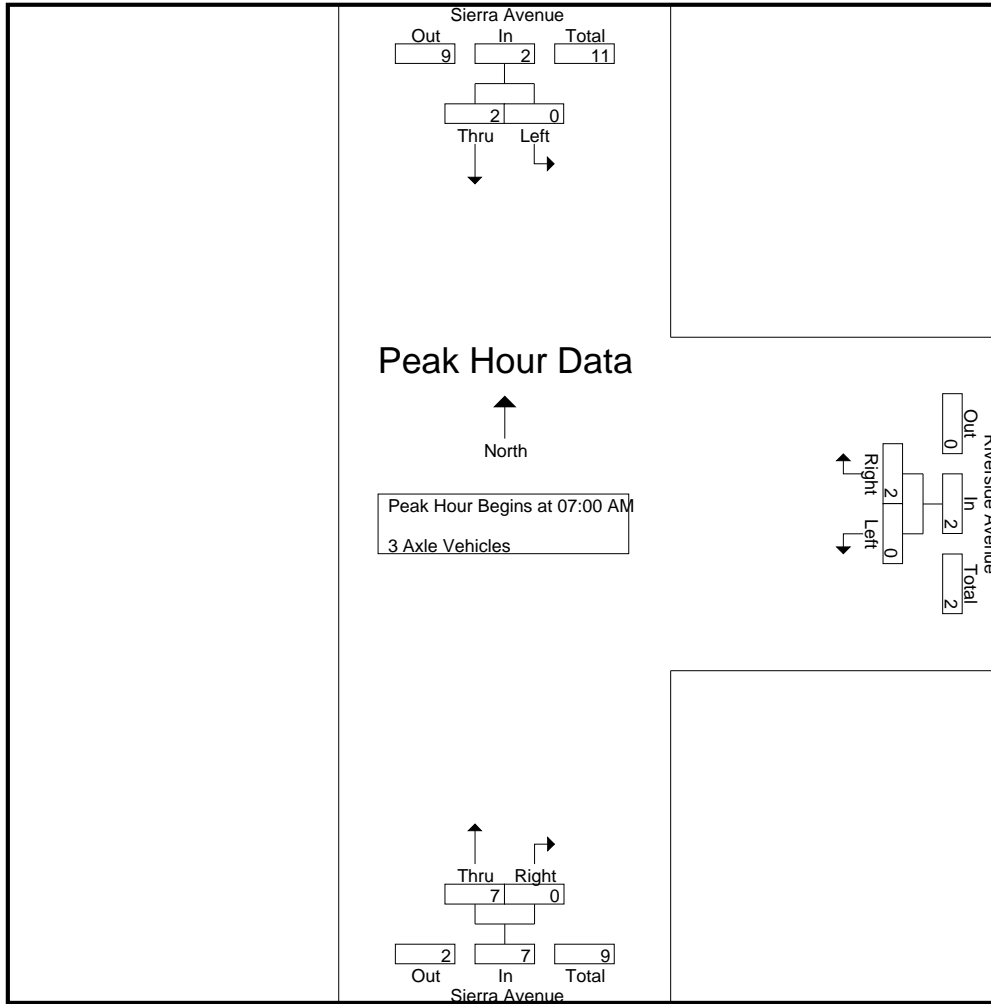

Peak Hour Analysis From 07:00 AM to 07:45 AM - Peak 1 of 1
 Peak Hour for Each Approach Begins at:

	07:00 AM			07:00 AM			07:00 AM		
+0 mins.	0	0	0	0	0	0	1	0	1
+15 mins.	0	0	0	0	0	0	1	0	1
+30 mins.	0	0	0	0	1	1	2	0	2
+45 mins.	0	2	2	0	1	1	3	0	3
Total Volume	0	2	2	0	2	2	7	0	7
% App. Total	0	100		0	100		100	0	
PHF	.000	.250	.250	.000	.500	.500	.583	.000	.583

City of Fontana
 N/S: Sierra Avenue
 E/W: Riverside Avenue
 Weather: Clear

File Name : 06_FON_Sierra_Riverside AM
 Site Code : 12218022
 Start Date : 1/24/2018
 Page No : 1

Groups Printed- 4+ Axle Trucks

Start Time	Sierra Avenue Southbound			Riverside Avenue Westbound			Sierra Avenue Northbound			Int. Total
	Left	Thru	App. Total	Left	Right	App. Total	Thru	Right	App. Total	
07:00 AM	8	0	8	0	2	2	0	0	0	10
07:15 AM	3	0	3	0	0	0	0	0	0	3
07:30 AM	3	0	3	0	4	4	1	0	1	8
07:45 AM	3	5	8	0	7	7	0	0	0	15
Total	17	5	22	0	13	13	1	0	1	36
08:00 AM	5	0	5	0	2	2	1	0	1	8
08:15 AM	4	1	5	0	1	1	2	0	2	8
08:30 AM	4	1	5	0	4	4	2	0	2	11
08:45 AM	2	4	6	0	5	5	0	0	0	11
Total	15	6	21	0	12	12	5	0	5	38
Grand Total	32	11	43	0	25	25	6	0	6	74
Apprch %	74.4	25.6		0	100		100	0		
Total %	43.2	14.9	58.1	0	33.8	33.8	8.1	0	8.1	

Start Time	Sierra Avenue Southbound			Riverside Avenue Westbound			Sierra Avenue Northbound			Int. Total
	Left	Thru	App. Total	Left	Right	App. Total	Thru	Right	App. Total	
07:00 AM	8	0	8	0	2	2	0	0	0	10
07:15 AM	3	0	3	0	0	0	0	0	0	3
07:30 AM	3	0	3	0	4	4	1	0	1	8
07:45 AM	3	5	8	0	7	7	0	0	0	15
Total Volume	17	5	22	0	13	13	1	0	1	36
% App. Total	77.3	22.7		0	100		100	0		
PHF	.531	.250	.688	.000	.464	.464	.250	.000	.250	.600

Peak Hour Analysis From 07:00 AM to 07:45 AM - Peak 1 of 1
 Peak Hour for Entire Intersection Begins at 07:00 AM

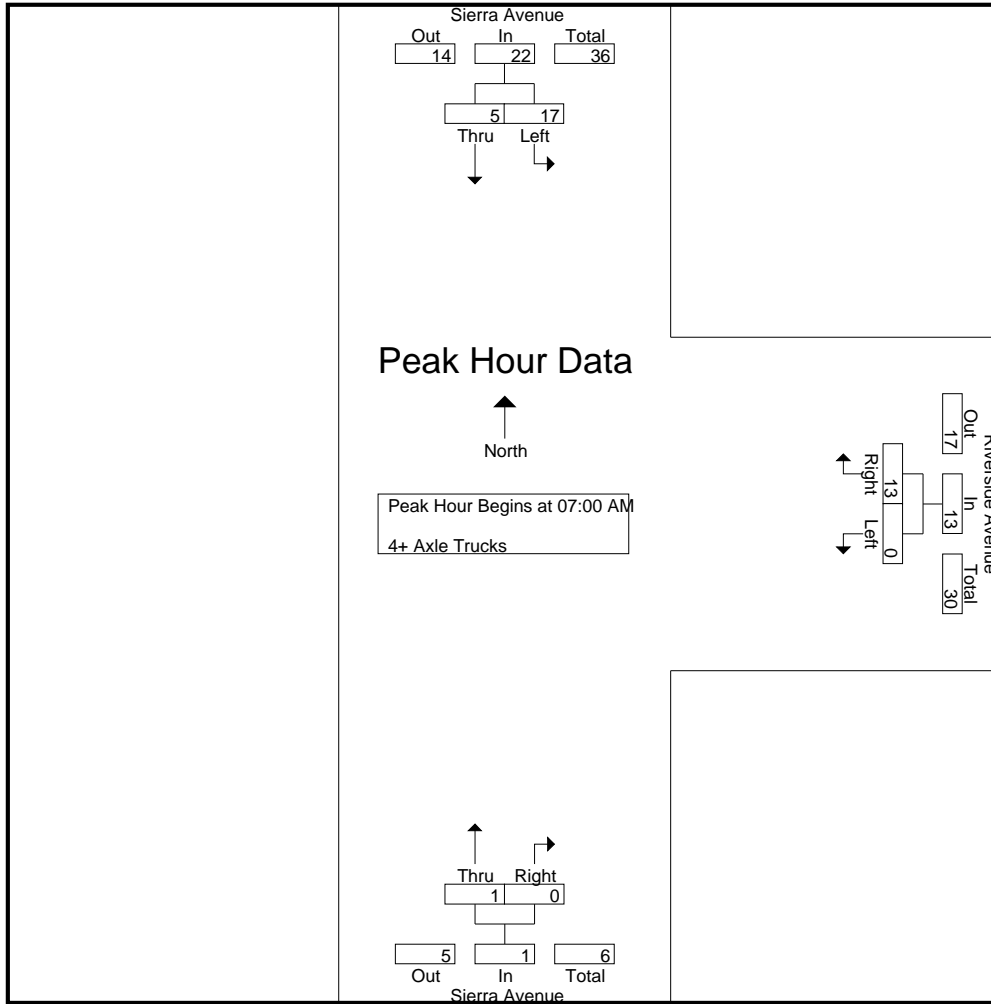

Peak Hour Analysis From 07:00 AM to 07:45 AM - Peak 1 of 1
 Peak Hour for Each Approach Begins at:

	07:00 AM			07:00 AM			07:00 AM		
+0 mins.	8	0	8	0	2	2	0	0	0
+15 mins.	3	0	3	0	0	0	0	0	0
+30 mins.	3	0	3	0	4	4	1	0	1
+45 mins.	3	5	8	0	7	7	0	0	0
Total Volume	17	5	22	0	13	13	1	0	1
% App. Total	77.3	22.7		0	100		100	0	
PHF	.531	.250	.688	.000	.464	.464	.250	.000	.250

City of Fontana
 N/S: Sierra Avenue
 E/W: Riverside Avenue
 Weather: Clear

File Name : 06_FON_Sierra_Riverside PM
 Site Code : 12218022
 Start Date : 1/24/2018
 Page No : 1

Groups Printed- Passenger Vehicles - Large 2 Axle Vehicles - 3 Axle Vehicles - 4+ Axle Trucks

Start Time	Sierra Avenue Southbound			Riverside Avenue Westbound			Sierra Avenue Northbound			Int. Total
	Left	Thru	App. Total	Left	Right	App. Total	Thru	Right	App. Total	
04:00 PM	115	141	256	5	84	89	118	7	125	470
04:15 PM	122	95	217	3	95	98	120	4	124	439
04:30 PM	93	84	177	7	119	126	119	0	119	422
04:45 PM	108	98	206	4	130	134	132	8	140	480
Total	438	418	856	19	428	447	489	19	508	1811
05:00 PM	122	93	215	6	90	96	121	6	127	438
05:15 PM	111	88	199	6	99	105	123	3	126	430
05:30 PM	101	85	186	9	80	89	122	1	123	398
05:45 PM	103	78	181	6	97	103	121	4	125	409
Total	437	344	781	27	366	393	487	14	501	1675
Grand Total	875	762	1637	46	794	840	976	33	1009	3486
Apprch %	53.5	46.5		5.5	94.5		96.7	3.3		
Total %	25.1	21.9	47	1.3	22.8	24.1	28	0.9	28.9	
Passenger Vehicles	843	749	1592	45	778	823	940	33	973	3388
% Passenger Vehicles	96.3	98.3	97.3	97.8	98	98	96.3	100	96.4	97.2
Large 2 Axle Vehicles	7	6	13	1	6	7	9	0	9	29
% Large 2 Axle Vehicles	0.8	0.8	0.8	2.2	0.8	0.8	0.9	0	0.9	0.8
3 Axle Vehicles	3	2	5	0	0	0	2	0	2	7
% 3 Axle Vehicles	0.3	0.3	0.3	0	0	0	0.2	0	0.2	0.2
4+ Axle Trucks	22	5	27	0	10	10	25	0	25	62
% 4+ Axle Trucks	2.5	0.7	1.6	0	1.3	1.2	2.6	0	2.5	1.8

Start Time	Sierra Avenue Southbound			Riverside Avenue Westbound			Sierra Avenue Northbound			Int. Total
	Left	Thru	App. Total	Left	Right	App. Total	Thru	Right	App. Total	
04:00 PM	115	141	256	5	84	89	118	7	125	470
04:15 PM	122	95	217	3	95	98	120	4	124	439
04:30 PM	93	84	177	7	119	126	119	0	119	422
04:45 PM	108	98	206	4	130	134	132	8	140	480
Total Volume	438	418	856	19	428	447	489	19	508	1811
% App. Total	51.2	48.8		4.3	95.7		96.3	3.7		
PHF	.898	.741	.836	.679	.823	.834	.926	.594	.907	.943

Peak Hour Analysis From 04:00 PM to 05:45 PM - Peak 1 of 1
 Peak Hour for Entire Intersection Begins at 04:00 PM

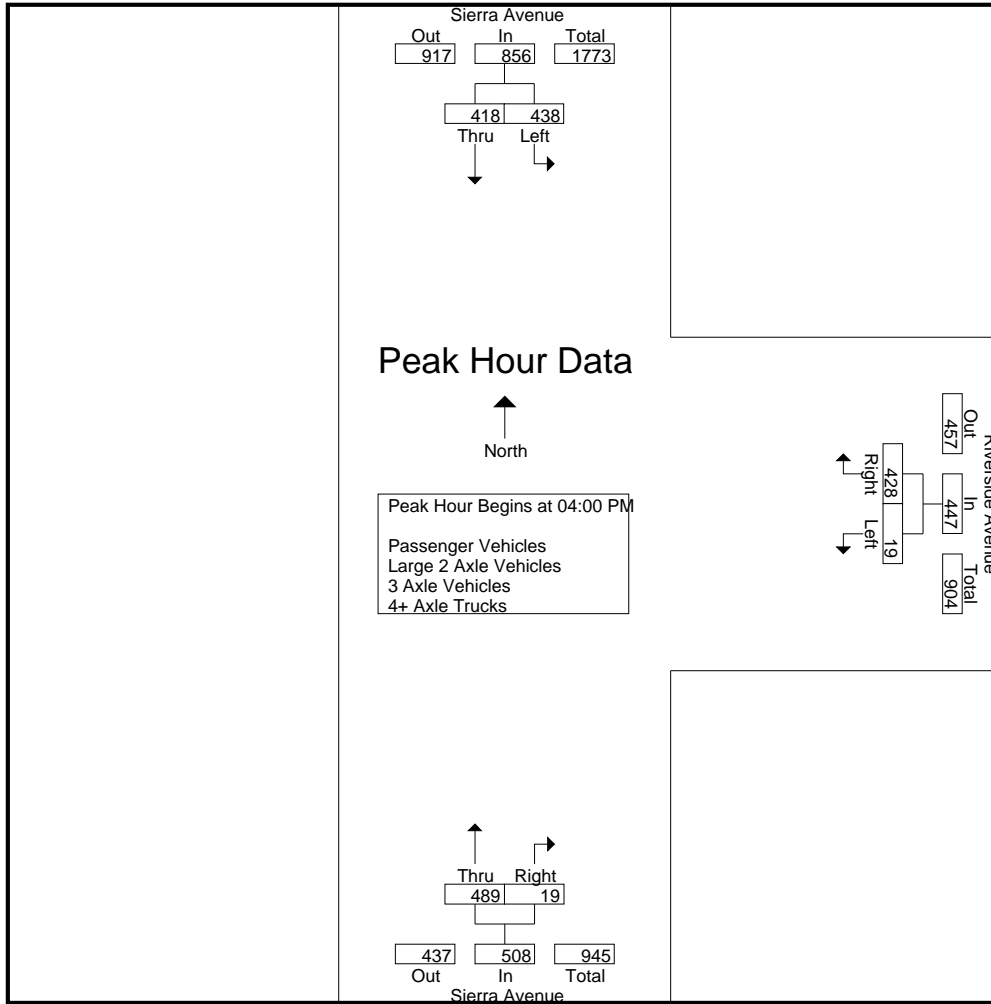

Peak Hour Analysis From 04:00 PM to 05:45 PM - Peak 1 of 1
 Peak Hour for Each Approach Begins at:

	04:00 PM			04:30 PM			04:45 PM		
+0 mins.	115	141	256	7	119	126	132	8	140
+15 mins.	122	95	217	4	130	134	121	6	127
+30 mins.	93	84	177	6	90	96	123	3	126
+45 mins.	108	98	206	6	99	105	122	1	123
Total Volume	438	418	856	23	438	461	498	18	516
% App. Total	51.2	48.8		5	95		96.5	3.5	
PHF	.898	.741	.836	.821	.842	.860	.943	.563	.921

City of Fontana
 N/S: Sierra Avenue
 E/W: Riverside Avenue
 Weather: Clear

File Name : 06_FON_Sierra_Riverside PM
 Site Code : 12218022
 Start Date : 1/24/2018
 Page No : 1

Groups Printed- Passenger Vehicles

Start Time	Sierra Avenue Southbound			Riverside Avenue Westbound			Sierra Avenue Northbound			Int. Total
	Left	Thru	App. Total	Left	Right	App. Total	Thru	Right	App. Total	
04:00 PM	112	138	250	5	81	86	111	7	118	454
04:15 PM	116	93	209	3	94	97	114	4	118	424
04:30 PM	90	81	171	6	118	124	113	0	113	408
04:45 PM	104	98	202	4	128	132	129	8	137	471
Total	422	410	832	18	421	439	467	19	486	1757
05:00 PM	118	93	211	6	87	93	118	6	124	428
05:15 PM	103	85	188	6	96	102	118	3	121	411
05:30 PM	99	84	183	9	78	87	120	1	121	391
05:45 PM	101	77	178	6	96	102	117	4	121	401
Total	421	339	760	27	357	384	473	14	487	1631
Grand Total	843	749	1592	45	778	823	940	33	973	3388
Apprch %	53	47		5.5	94.5		96.6	3.4		
Total %	24.9	22.1	47	1.3	23	24.3	27.7	1	28.7	

Start Time	Sierra Avenue Southbound			Riverside Avenue Westbound			Sierra Avenue Northbound			Int. Total
	Left	Thru	App. Total	Left	Right	App. Total	Thru	Right	App. Total	
04:00 PM	112	138	250	5	81	86	111	7	118	454
04:15 PM	116	93	209	3	94	97	114	4	118	424
04:30 PM	90	81	171	6	118	124	113	0	113	408
04:45 PM	104	98	202	4	128	132	129	8	137	471
Total Volume	422	410	832	18	421	439	467	19	486	1757
% App. Total	50.7	49.3		4.1	95.9		96.1	3.9		
PHF	.909	.743	.832	.750	.822	.831	.905	.594	.887	.933

Peak Hour Analysis From 04:00 PM to 04:45 PM - Peak 1 of 1
 Peak Hour for Entire Intersection Begins at 04:00 PM

City of Fontana
 N/S: Sierra Avenue
 E/W: Riverside Avenue
 Weather: Clear

File Name : 06_FON_Sierra_Riverside PM
 Site Code : 12218022
 Start Date : 1/24/2018
 Page No : 2

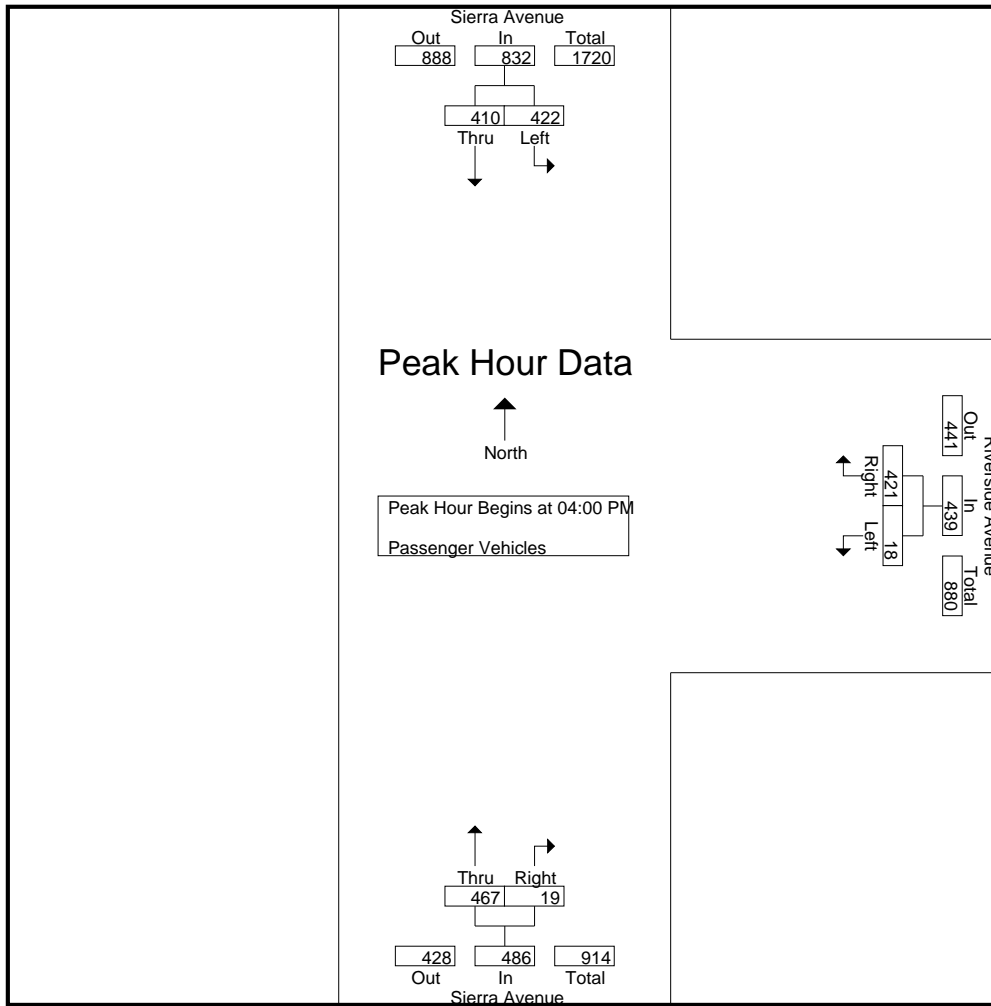

Peak Hour Analysis From 04:00 PM to 04:45 PM - Peak 1 of 1
 Peak Hour for Each Approach Begins at:

	04:00 PM			04:00 PM			04:00 PM		
+0 mins.	112	138	250	5	81	86	111	7	118
+15 mins.	116	93	209	3	94	97	114	4	118
+30 mins.	90	81	171	6	118	124	113	0	113
+45 mins.	104	98	202	4	128	132	129	8	137
Total Volume	422	410	832	18	421	439	467	19	486
% App. Total	50.7	49.3		4.1	95.9		96.1	3.9	
PHF	.909	.743	.832	.750	.822	.831	.905	.594	.887

City of Fontana
 N/S: Sierra Avenue
 E/W: Riverside Avenue
 Weather: Clear

File Name : 06_FON_Sierra_Riverside PM
 Site Code : 12218022
 Start Date : 1/24/2018
 Page No : 1

Groups Printed- Large 2 Axle Vehicles

Start Time	Sierra Avenue Southbound			Riverside Avenue Westbound			Sierra Avenue Northbound			Int. Total
	Left	Thru	App. Total	Left	Right	App. Total	Thru	Right	App. Total	
04:00 PM	0	2	2	0	1	1	2	0	2	5
04:15 PM	1	1	2	0	0	0	1	0	1	3
04:30 PM	2	1	3	1	0	1	2	0	2	6
04:45 PM	1	0	1	0	1	1	0	0	0	2
Total	4	4	8	1	2	3	5	0	5	16
05:00 PM	2	0	2	0	1	1	0	0	0	3
05:15 PM	1	2	3	0	2	2	2	0	2	7
05:30 PM	0	0	0	0	0	0	0	0	0	0
05:45 PM	0	0	0	0	1	1	2	0	2	3
Total	3	2	5	0	4	4	4	0	4	13
Grand Total	7	6	13	1	6	7	9	0	9	29
Apprch %	53.8	46.2		14.3	85.7		100	0		
Total %	24.1	20.7	44.8	3.4	20.7	24.1	31	0	31	

Start Time	Sierra Avenue Southbound			Riverside Avenue Westbound			Sierra Avenue Northbound			Int. Total
	Left	Thru	App. Total	Left	Right	App. Total	Thru	Right	App. Total	
04:00 PM	0	2	2	0	1	1	2	0	2	5
04:15 PM	1	1	2	0	0	0	1	0	1	3
04:30 PM	2	1	3	1	0	1	2	0	2	6
04:45 PM	1	0	1	0	1	1	0	0	0	2
Total Volume	4	4	8	1	2	3	5	0	5	16
% App. Total	50	50		33.3	66.7		100	0		
PHF	.500	.500	.667	.250	.500	.750	.625	.000	.625	.667

Peak Hour Analysis From 04:00 PM to 04:45 PM - Peak 1 of 1
 Peak Hour for Entire Intersection Begins at 04:00 PM

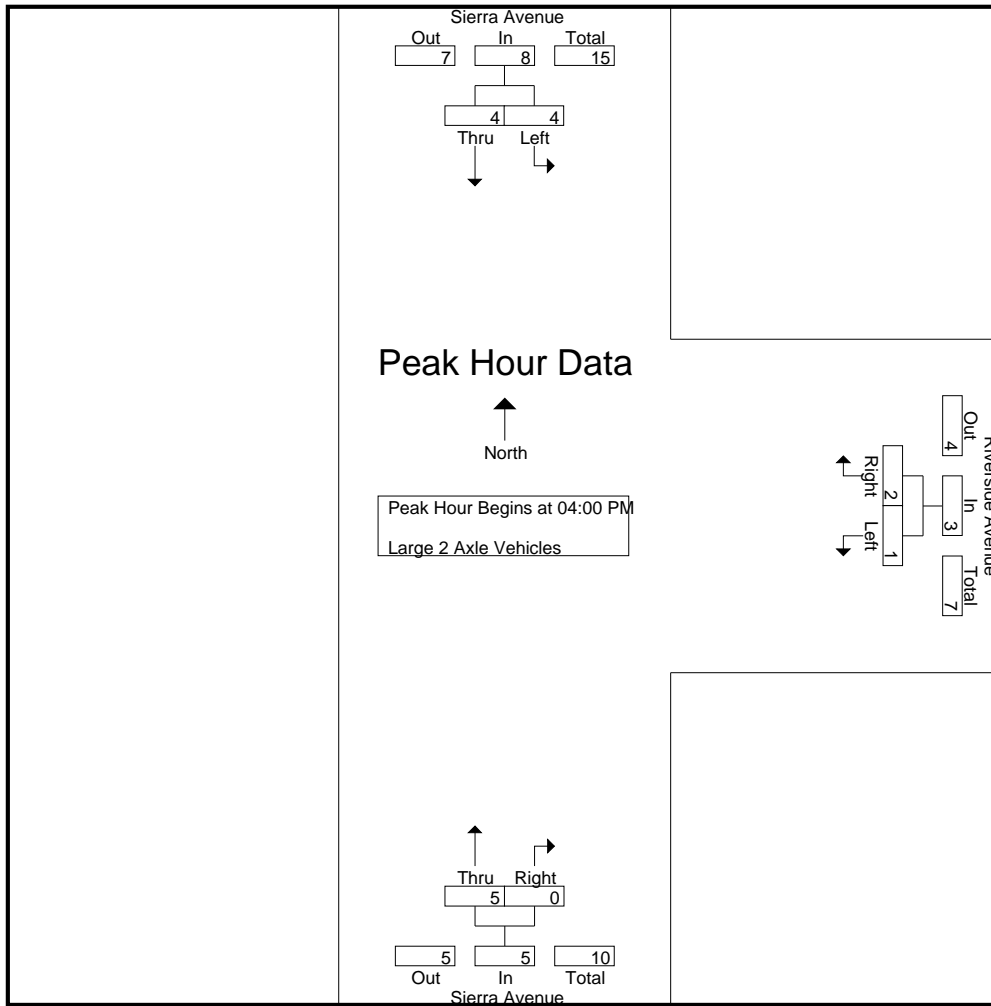

Peak Hour Analysis From 04:00 PM to 04:45 PM - Peak 1 of 1
 Peak Hour for Each Approach Begins at:

	04:00 PM			04:00 PM			04:00 PM		
+0 mins.	0	2	2	0	1	1	2	0	2
+15 mins.	1	1	2	0	0	0	1	0	1
+30 mins.	2	1	3	1	0	1	2	0	2
+45 mins.	1	0	1	0	1	1	0	0	0
Total Volume	4	4	8	1	2	3	5	0	5
% App. Total	50	50		33.3	66.7		100	0	
PHF	.500	.500	.667	.250	.500	.750	.625	.000	.625

City of Fontana
 N/S: Sierra Avenue
 E/W: Riverside Avenue
 Weather: Clear

File Name : 06_FON_Sierra_Riverside PM
 Site Code : 12218022
 Start Date : 1/24/2018
 Page No : 1

Groups Printed- 4+ Axle Trucks

Start Time	Sierra Avenue Southbound			Riverside Avenue Westbound			Sierra Avenue Northbound			Int. Total
	Left	Thru	App. Total	Left	Right	App. Total	Thru	Right	App. Total	
04:00 PM	3	0	3	0	2	2	5	0	5	10
04:15 PM	4	1	5	0	1	1	5	0	5	11
04:30 PM	1	1	2	0	1	1	4	0	4	7
04:45 PM	2	0	2	0	1	1	3	0	3	6
Total	10	2	12	0	5	5	17	0	17	34
05:00 PM	1	0	1	0	2	2	2	0	2	5
05:15 PM	7	1	8	0	1	1	2	0	2	11
05:30 PM	2	1	3	0	2	2	2	0	2	7
05:45 PM	2	1	3	0	0	0	2	0	2	5
Total	12	3	15	0	5	5	8	0	8	28
Grand Total	22	5	27	0	10	10	25	0	25	62
Apprch %	81.5	18.5		0	100		100	0		
Total %	35.5	8.1	43.5	0	16.1	16.1	40.3	0	40.3	

Start Time	Sierra Avenue Southbound			Riverside Avenue Westbound			Sierra Avenue Northbound			Int. Total
	Left	Thru	App. Total	Left	Right	App. Total	Thru	Right	App. Total	
04:00 PM	3	0	3	0	2	2	5	0	5	10
04:15 PM	4	1	5	0	1	1	5	0	5	11
04:30 PM	1	1	2	0	1	1	4	0	4	7
04:45 PM	2	0	2	0	1	1	3	0	3	6
Total Volume	10	2	12	0	5	5	17	0	17	34
% App. Total	83.3	16.7		0	100		100	0		
PHF	.625	.500	.600	.000	.625	.625	.850	.000	.850	.773

Peak Hour Analysis From 04:00 PM to 04:45 PM - Peak 1 of 1
 Peak Hour for Entire Intersection Begins at 04:00 PM

City of Fontana
 N/S: Sierra Avenue
 E/W: Riverside Avenue
 Weather: Clear

File Name : 06_FON_Sierra_Riverside PM
 Site Code : 12218022
 Start Date : 1/24/2018
 Page No : 2

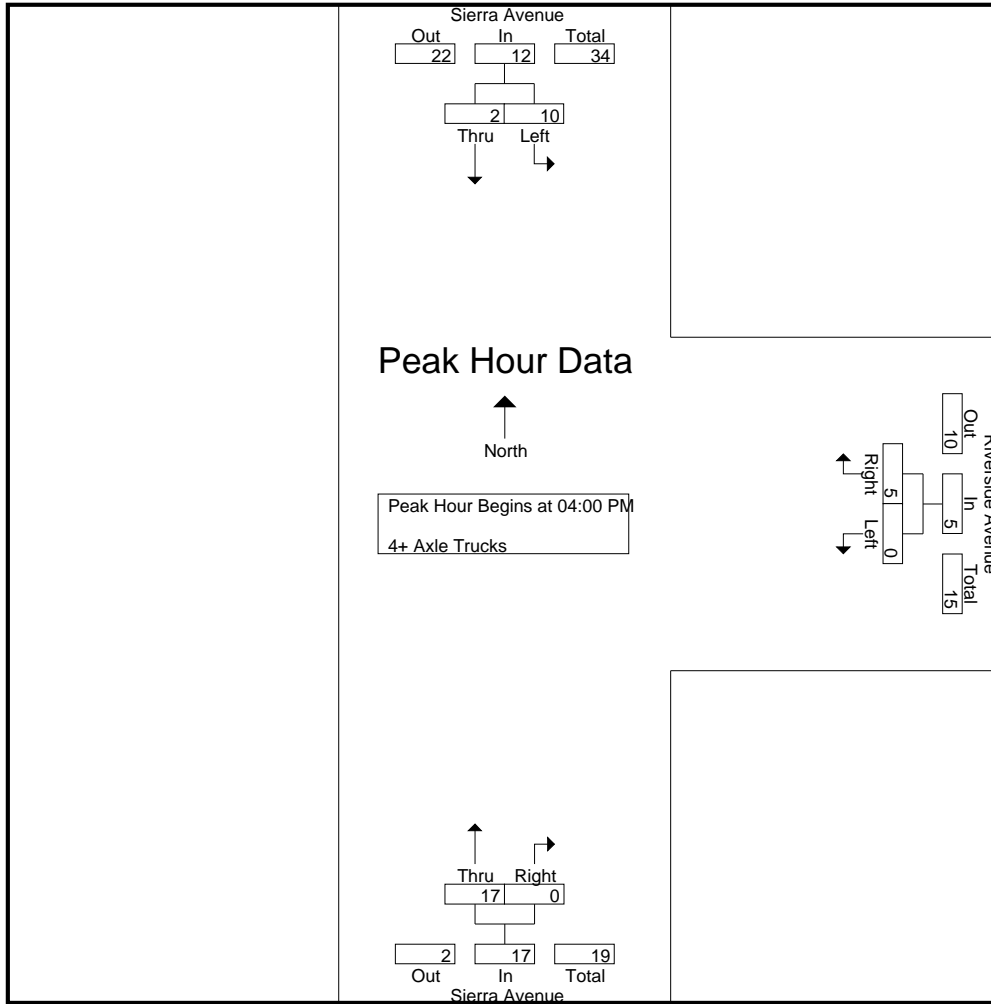

Peak Hour Analysis From 04:00 PM to 04:45 PM - Peak 1 of 1
 Peak Hour for Each Approach Begins at:

	04:00 PM			04:00 PM			04:00 PM		
+0 mins.	3	0	3	0	2	2	5	0	5
+15 mins.	4	1	5	0	1	1	5	0	5
+30 mins.	1	1	2	0	1	1	4	0	4
+45 mins.	2	0	2	0	1	1	3	0	3
Total Volume	10	2	12	0	5	5	17	0	17
% App. Total	83.3	16.7		0	100		100	0	
PHF	.625	.500	.600	.000	.625	.625	.850	.000	.850

OPENING YEAR 2020 WITH PROJECT CONDITIONS PEAK HOUR VOLUME WARRANT RURAL CONDITIONS

(COMMUNITY LESS THAN 10,000 POPULATION OR ABOVE 70 km/h (40 mph) ON MAJOR STREET)

Peak Hour: **AM**

Major Street: **Duncan Canyon Road**

Minor Street: **Coyote Canyon Road**

Total of Both Approaches (VPH): **662**
Number of Approach Lanes: **2**

Higher Volume Approach (VPH): **456**
Number of Approach Lanes: **2**

SIGNAL WARRANT SATISFIED

Figure 4C-4. Peak Hour Warrant (Rural)

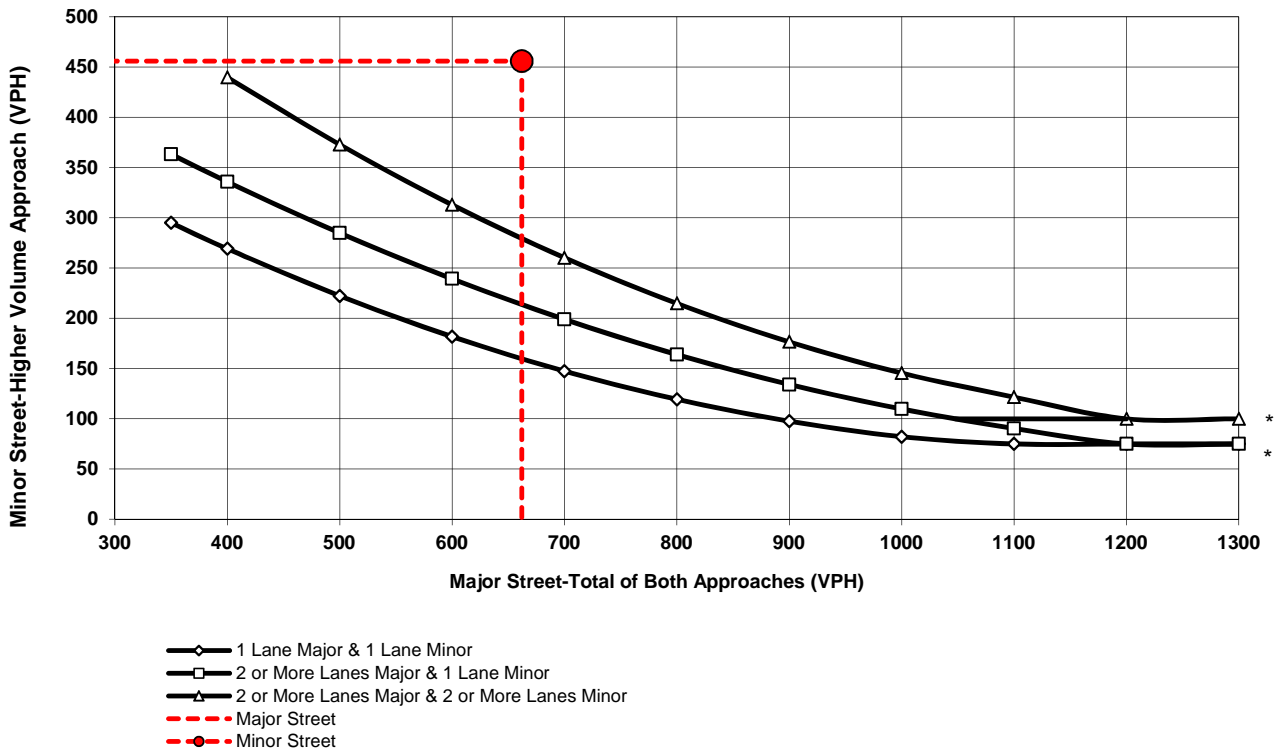

* Note:

100 vph Applies as the Lower Threshold Volume for a Minor Street Approach with Two or More Lanes and 75 vph Applies as the Lower Threshold Volume for a Minor Street Approach with One Lane.

Source: California MUTCD 2014 Revision 1

OPENING YEAR 2020 WITH PROJECT CONDITIONS PEAK HOUR VOLUME WARRANT RURAL CONDITIONS

(COMMUNITY LESS THAN 10,000 POPULATION OR ABOVE 70 km/h (40 mph) ON MAJOR STREET)

Peak Hour: **PM**

Major Street: **Duncan Canyon Road**

Minor Street: **Coyote Canyon Road**

Total of Both Approaches (VPH): **1107**
Number of Approach Lanes: **2**

Higher Volume Approach (VPH): **323**
Number of Approach Lanes: **2**

SIGNAL WARRANT SATISFIED

Figure 4C-4. Peak Hour Warrant (Rural)

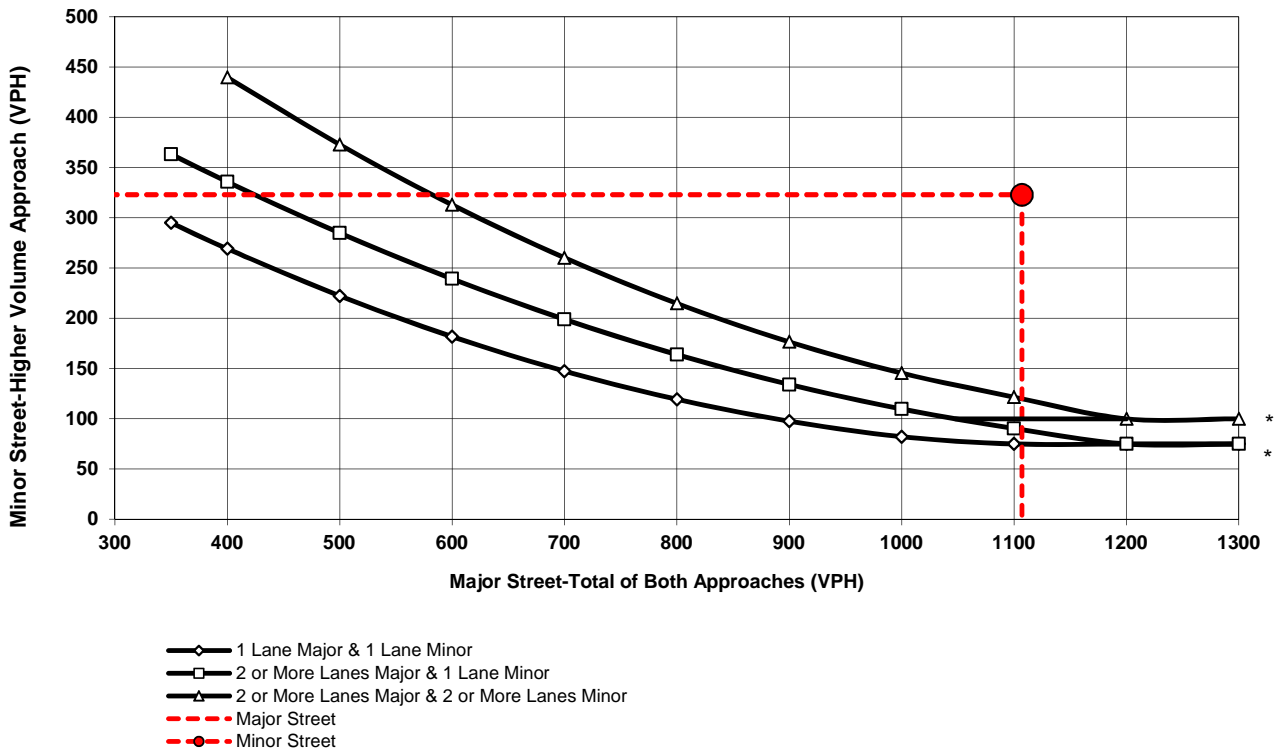

* Note:

100 vph Applies as the Lower Threshold Volume for a Minor Street Approach with Two or More Lanes and 75 vph Applies as the Lower Threshold Volume for a Minor Street Approach with One Lane.

Source: California MUTCD 2014 Revision 1

Michael Baker
INTERNATIONAL

Appendix B Traffic Study Scoping Agreement

This page intentionally left blank

SCOPING AGREEMENT FOR TRAFFIC IMPACT ANALYSIS

This letter acknowledges the City of Fontana Engineering Department requirements for traffic impact analysis of the following project. The analysis must follow the SANBAG Traffic Study Guidelines Updated 2016.

Case No. (Required for submittal) – Not Available

Related Cases - Not Applicable

SP No. - Not Applicable

EIR No. – Not Available

General Plan Amendment No. 15-005 is a request to assign a General Plan Land Use Designation of Residential Estate (R-E) to APN 0239-041-15 and to the portions of APNs 0239-091-13 & 14. Also, change the General Plan Land Use Designation on approx. 76 acres from Residential Estate (R-E) and General Commercial (C-2) to Light Industrial (M-1); and to change APN: 0239-093-08 from Residential Estate (R-E) to Public Utility Corridor (P-UC). **General Plan Amendment No. 17-001** is a request to change the General Plan Circulation Element Designation for Lytle Creek Road from a four-lane Secondary Highway to a two-lane Collector.

Zone Change No. 15-009 is a request to assign a pre-zone Designation of Residential Estate (R-E) to APN 0239-041-15 and to the portions of APNs 0239-091-13 and 14 that currently do not have a pre-zone designation. Also, change the zoning district on approximately 76 acres from Residential Estate (R-E) and General Commercial (C-2) to Light Industrial (M-1) and change the zoning on APN: 0239-093-08 from Residential Estate (R-E) to Public Utility Corridor (P-UC).

Project Name: I-15 Logistics Center (CapRock Warehouse Project)

Project Address: Project is located between Lytle Creek Road and I-15 just west of Sierra Avenue

Project Description: Proposed 1,175,720 square feet of high-cube warehouse

	<u>Consultant</u>	<u>Developer</u>
Name:	<u>Carla Dietrich – Michael Baker International</u>	<u>Patrick Daniels - CapRock Partners</u>
Address:	<u>3536 Concours Street, Suite 100</u> <u>Ontario, CA 91764</u>	<u>2050 Main Street, Suite 240</u> <u>Irvine, CA 92614</u>
Telephone:	<u>(909) 974-4908</u>	<u>(949) 342-8000</u>
Fax:	<u>(909) 974-4900</u>	<u>(949) 340-5474</u>

A. Trip Generation Source: (ITE 10th Edition), See **Attachment A**

Current GP Land Use	<u>Vacant</u>	Proposed Land Use	<u>Warehouse (Code 150)</u>
Current Zoning	<u>RS-1</u>	Proposed Zoning	<u>M-2 / S-1 / B</u>

	<u>Current Trip Generation</u>			<u>Proposed Trip Generation (PCE's)</u>		
	In	Out	Total	In	Out	Total
AM Trips	<u>0</u>	<u>0</u>	<u>0</u>	<u>232</u>	<u>73</u>	<u>305</u>
PM Trips	<u>0</u>	<u>0</u>	<u>0</u>	<u>90</u>	<u>250</u>	<u>340</u>

Internal Trip Allowance Yes No (0 % Trip Discount)

Pass-By Trip Allowance Yes No (0 % Trip Discount)

A pass-by trip discount of up to 25% is allowed for appropriate land uses. The pass-by trips at adjacent study area intersections and project driveways shall be indicated on a report figure.

B. Trip Geographic Distribution: N ____% S ____% E ____% W ____%
(See **Attachment B-1 & B-2** for area distribution exhibits, **Attachments C-1 & C-2** for detailed intersection distributions, and **Attachment D** for AM/PM peak hour project trips.)

C. Background Traffic

Project Build-out Year: Year 2020 Annual Ambient Growth Rate: 2% compounded
Phase Year(s) Project is assumed to be built in one phase.

Traffic Impact Analysis will include the following study scenarios:

- Existing Conditions
- Existing Plus Project Conditions
- Opening Year Without Project Conditions
- Opening Year With Project Conditions
- Future (Year 2040) Without Project Conditions
- Future (Year 2040) With Project Conditions

Other area projects to be analyzed (Cumulative project list for City of Fontana, City of Rialto and San Bernardino County to be approved by City):

Attachment E includes a list of cumulative projects located within the City of Fontana to be reviewed and considered for inclusion in the traffic study. In addition to those projects, the following will also be included in the analysis.

- 1.) Lytle Creek Village (City of Fontana) – 650 multi-family dwelling units; 70,000 square feet of commercial; 45,000 square foot church.
- 2.) Sycamore Creek (P201700019/CF) (San Bernardino County) – 298 apartments, 90 condominiums. This project is located near Sycamore Creek Drive and Sycamore Creek Loop.
- 3.) Renaissance Specific Plan (City of Rialto) – 1,262 residential units; 715,300 SF retail (town center); 386,700 SF freeway commercial; 28,300 SF general commercial; 319,900 SF corporate center use; 6,900,000 SF business center; 7,100,00 SF employment uses; 923,700 SF freeway incubator, a school, and park uses. [Source: *Traffic Impact Analysis, Renaissance Specific Plan Amendment*, LSA Associates, 2016].

Model/Forecast methodology: San Bernardino County Transportation Analysis Model (SBTAM)

D. Study intersections: (NOTE: Subject to revision after other projects, trip generation and distribution are determined, or comments from other agencies.) (**Attachment F** shows which study intersections will be analyzed in each scenario.)

1. Duncan Canyon Road / Coyote Canyon Road
2. Duncan Canyon Road / Lytle Creek Road
3. Lytle Creek Road / Project Driveway
4. Lytle Creek Road / Public Access Road
5. Sierra Avenue / Lytle Creek Road (without realignment)
6. Sierra Avenue / Lytle Creek Road (signalized with realignment)
7. I-15 Southbound Ramps / Sierra Avenue
8. I-15 Northbound Ramps / Sierra Avenue
9. Sierra Avenue / Riverside Avenue

E. Study Roadway Segments: (NOTE: Subject to revision after other projects, trip generation and distribution are determined, or comments from other agencies.)

1. Lytle Creek Road between Duncan Canyon Road and Sierra Avenue
2. Lytle Creek Road between Project Driveway and Public Access Road
3. Lytle Creek Road between Public Access Road and Sierra Avenue

F. Other Jurisdictional Impacts

Is this project within a City’s Sphere of Influence or one-mile radius of City boundaries? Yes No
If so, name of City Jurisdiction: City of Rialto

G. Site Plan (please see attached reduced copy) [see **Attachment G**]

H. Specific issues to be addressed in the Study (in addition to the standard analysis described in the Guideline) (To be filled out by Engineering Department) (NOTE: If the traffic study states that “a traffic signal is warranted” (or “a traffic signal appears to be warranted”, or a similar statement) at an unsignalized intersection under existing conditions, 8-hour approach traffic volume information must be submitted in addition to the peak hourly turning movement counts for that intersection.)

The project will also include the construction of new Lytle Creek Road to Sierra Avenue extension from the property’s northern boundary and continuing northeast for approximately .42 miles. All “With Project” scenarios for the traffic study will include this roadway realignment.

I. Existing Conditions

Traffic count data must be new midweek counts collected while school is in session, not during holiday breaks, based on City of Fontana TIA Guidelines.

Date of counts: New Counts will be collected.

Recommended by:

Approved Scoping Agreement:

Carla Dietrich

Consultants Representative

Date

City of Fontana Project Engineer

Date

Scoping Agreement Submitted on: 9/25/17

Revised on: 1/4/2018

**ATTACHMENT A
CAPROCK WAREHOUSE TRIP GENERATION**

**Table A-1
Trip Generation Rates**

Vehicle Type Breakdown ¹		Daily Trip Rate ²	AM Peak Hour ²		PM Peak Hour ²	
			Rate	In : Out	Rate	In : Out
Passenger Car	69.00%	1.201 / KSF	0.117	77% : 23%	0.131	27% : 73%
2 Axle Truck	6.80%	0.118 / KSF	0.012		0.013	
3 Axle Truck	5.50%	0.096 / KSF	0.009		0.010	
4+ Axle Truck	18.70%	0.325 / KSF	0.032		0.036	
Total Trucks	31.00%	0.539 / KSF	0.053		0.059	
Total	100%	1.74 / KSF	0.17		0.19	

Notes:

KSF= Thousand Square Feet

¹Source: SCAQMD

²Source: ITE Trip Generation Manual, 10th edition. Land Use Code: 150

**Table A-2
Caprock Warehouse Trip Generation
Trip Generation in Vehicles**

Warehouse		Daily Trips	AM Peak Hour			PM Peak Hour			
Vehicle Type Breakdown ¹	Intensity		Volume	Inbound	Outbound	Volume	Inbound	Outbound	
Passenger Car	69.00%	1,175.72 KSF	1,412	138	106	32	154	42	112
2 Axle Truck	6.8%		139	14	11	3	15	4	11
3 Axle Truck	5.5%		113	11	8	3	12	3	9
4+ Axle Truck	18.7%		383	37	28	9	42	11	31
Total Trucks	31.0%		634	62	48	14	69	19	50
Total	100.0%		2,046	200	154	46	223	60	163

Trip Generation in PCE's

Warehouse		Daily Trips	AM Peak Hour			PM Peak Hour		
Vehicle Type Breakdown ¹	PCE ²		Volume	Inbound	Outbound	Volume	Inbound	Outbound
Passenger Car	69.0%	1,412	138	106	32	154	42	112
2 Axle Truck	6.8%	278	28	22	6	30	8	22
3 Axle Truck	5.5%	283	28	20	8	30	7	23
4+ Axle Truck	18.7%	1,149	111	84	27	126	33	93
Total Trucks	31.0%	1,710	167	126	41	186	48	138
Total	100.0%	3,122	305	232	73	340	90	250

Notes:



¹Source: SCAQMD

²PCE=City of Fontana TIA Guidelines

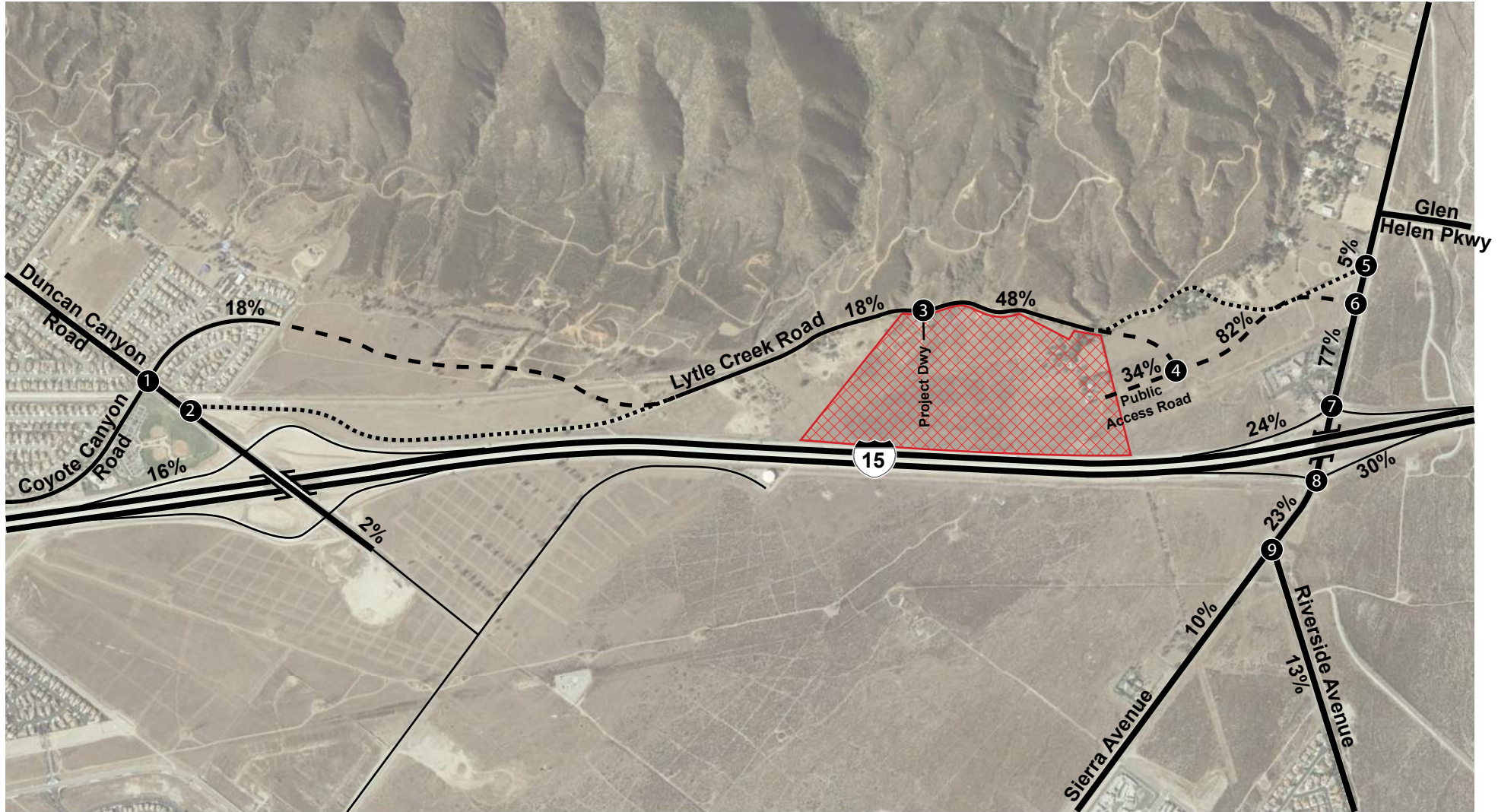
Intensity = 1,175,720 square feet



Legend:

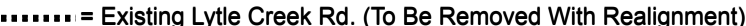

-  = Project Site **##%** = Project Site
-  = Study Intersection
-  = Future Proposed Roadway
-  = Existing Lytle Creek Rd. (To Be Removed With Realignment)

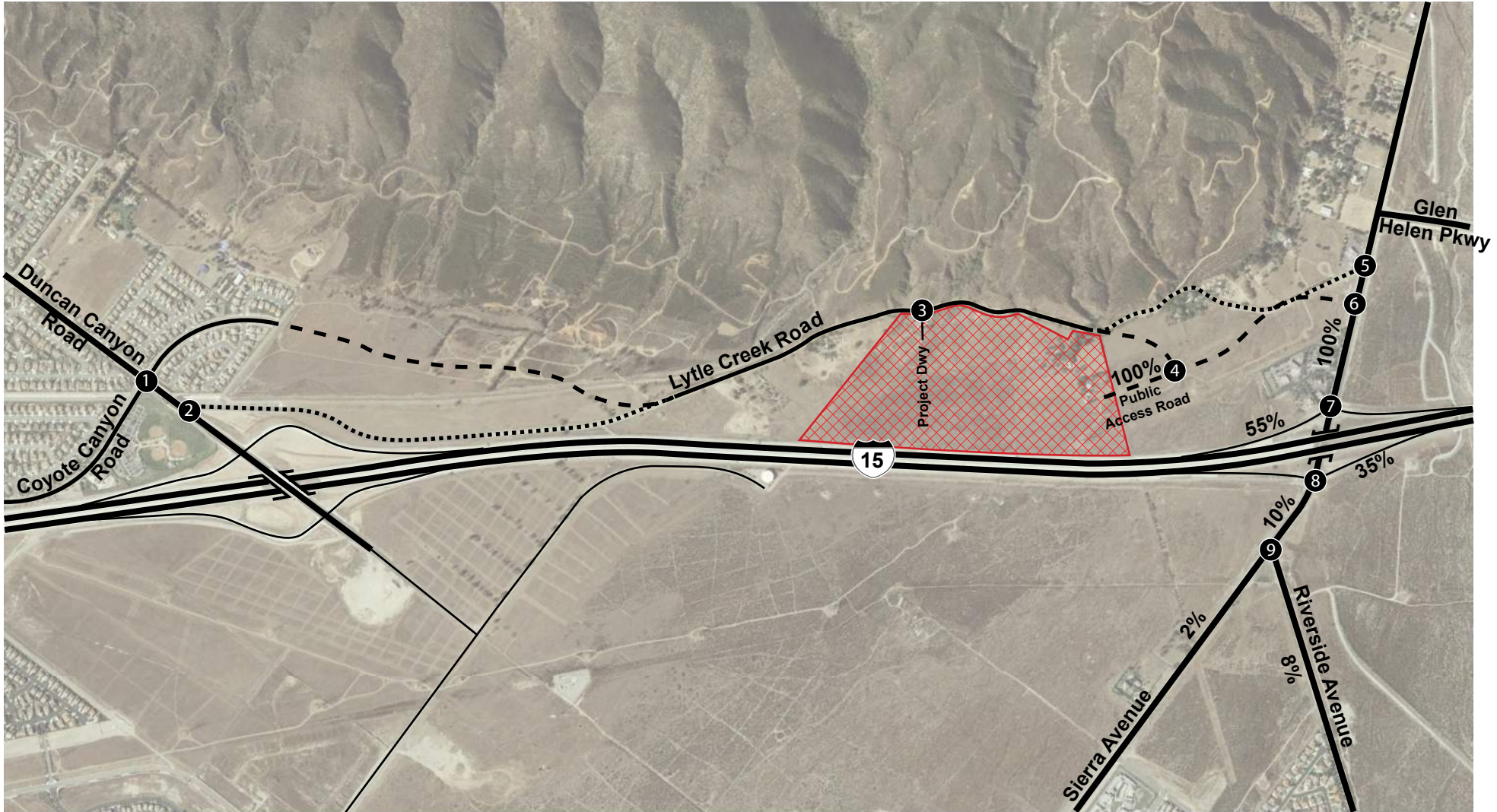

Not to Scale

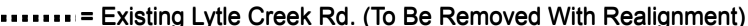

Legend:

-  = Project Site
-  = Study Intersection
-  = Future Proposed Roadway
-  = Existing Lytle Creek Rd. (To Be Removed With Realignment)
- ###%** = Project Site



Not to Scale

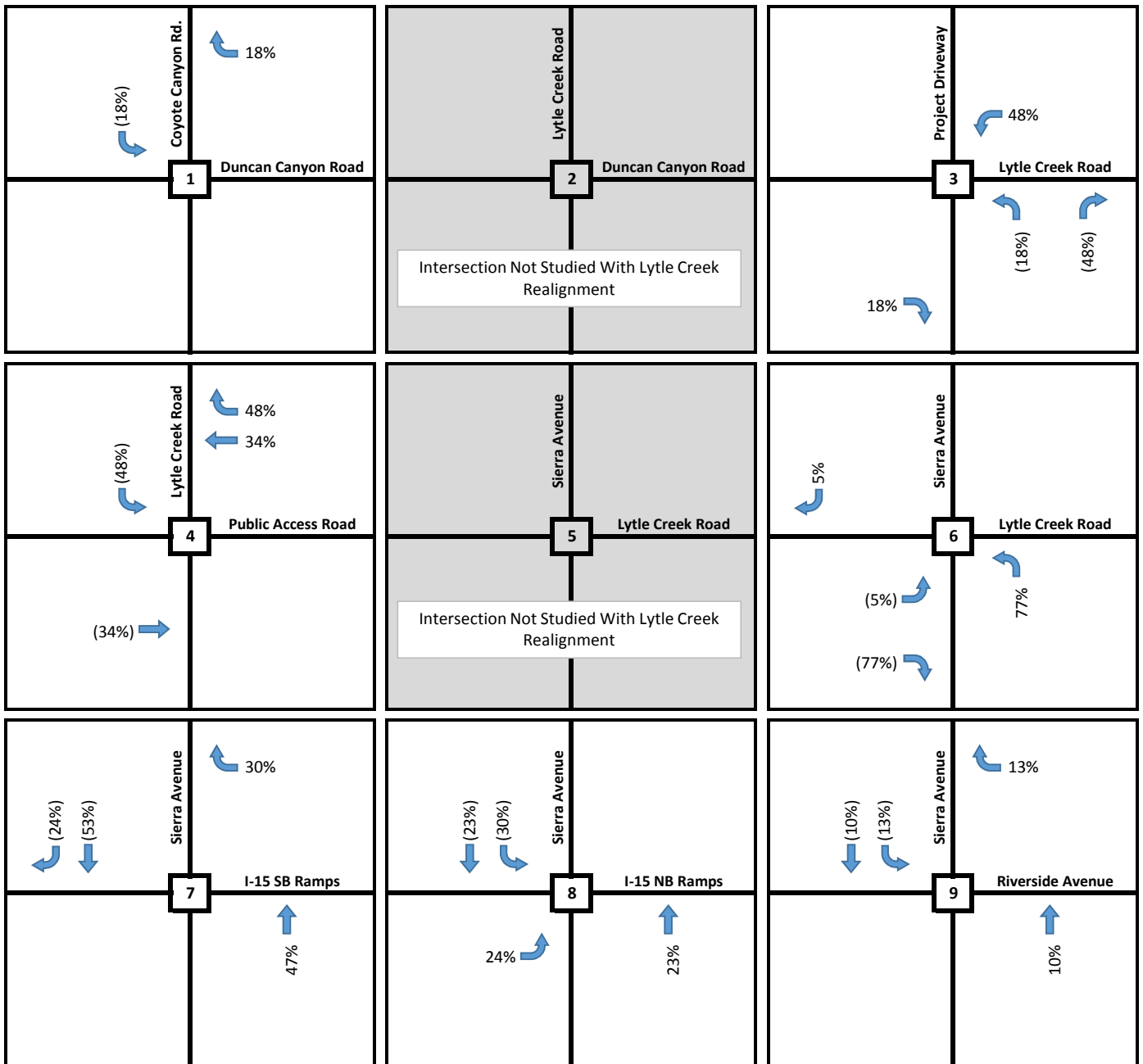

Notes:

XX% = Inbound Distribution Percentage

(XX%) = Outbound Distribution Percentage

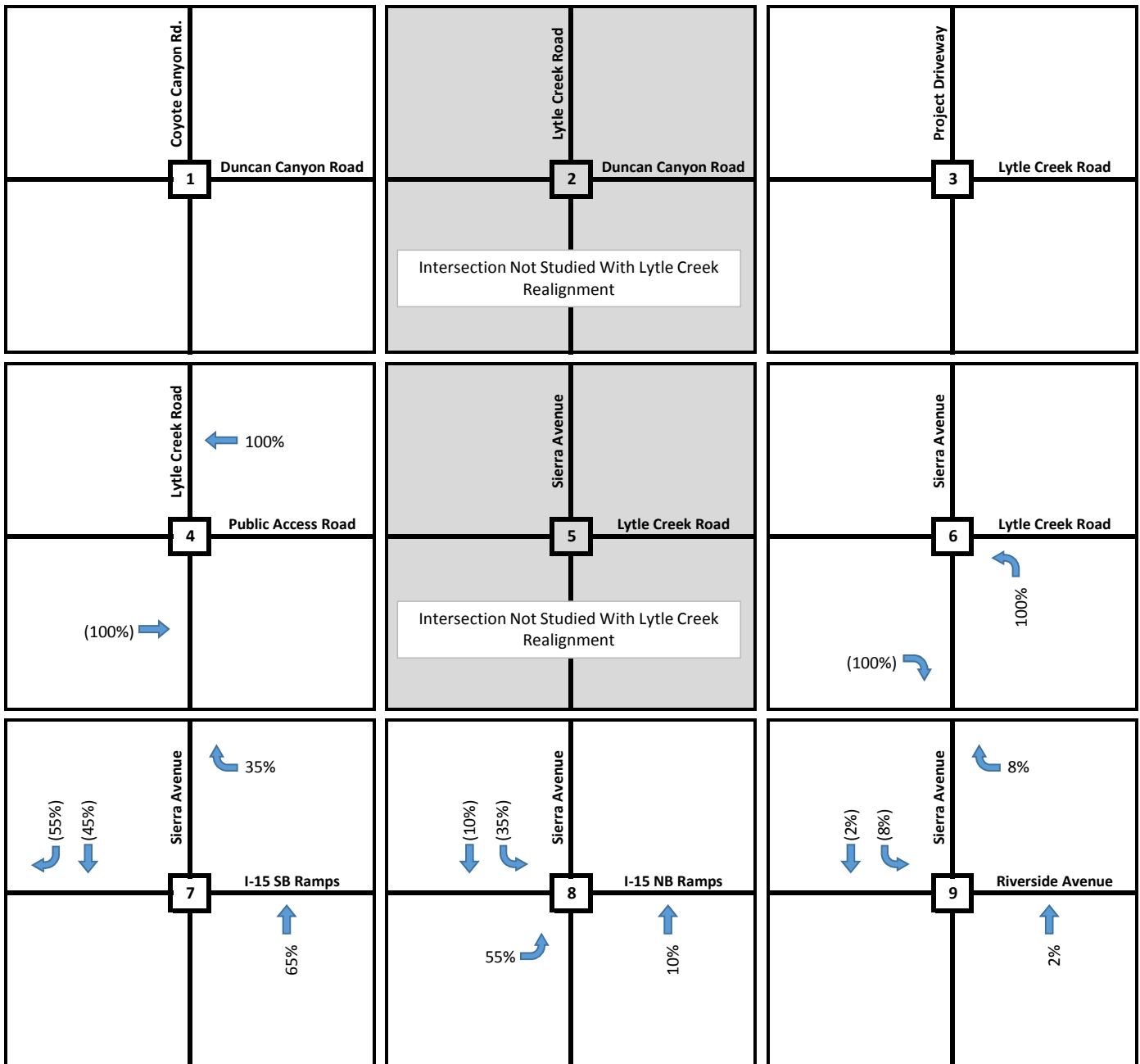

Notes:

XX% = Inbound Distribution Percentage

(XX%) = Outbound Distribution Percentage

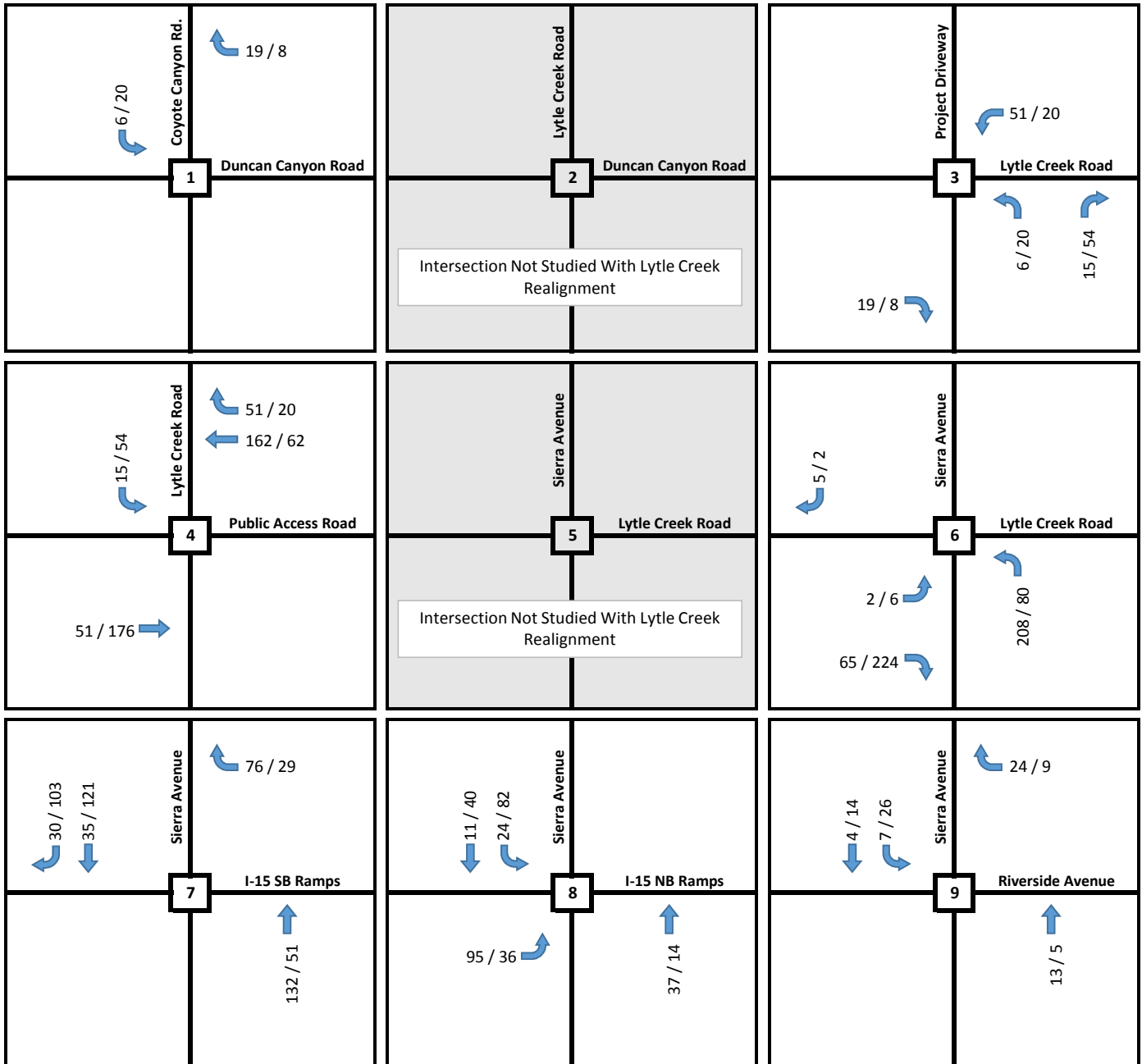

Notes: XX / XX = AM / PM Peak Hour Volumes

ATTACHMENT E

North of the 210 FWY

Monarch Hills

Single Family Residential	233 SFD
Multi family Residential	256 MFD

Cap Rock

Warehouse Facility	1175.72 TSF
--------------------	-------------

Sierra Crest II - Tract 18944

Single Family Residential	179 D. U.
---------------------------	-----------

Sierra Lakes Commerce Center - 6101 Sierra Ave

Warehouse Facility	597.82 TSF
--------------------	------------

Summit Crest (KB Homes) Tract 18825-1

Single Family Residential	76 D.U.
---------------------------	---------

Stratham Development - Tract 18825

Single Family Residential	76 D.U.
---------------------------	---------

Tract 18915

Single Family Residential	18 D.U.
---------------------------	---------

Stone Haven - Tract 18881

Single Family Residential	96 D.U.
---------------------------	---------

Steven Walker Communities - Tract 18987

Single Family Residential	102 D.U.
---------------------------	----------

Grand Pacific Communities - Tract 18981

Single Family Residential	105 D.U.
---------------------------	----------

Citrus Heights North - Tracts 16876, 16876-1, 17039, 17041

Private Park	1.5 Acres
Single Family Residential (PA 3, PA 13)	167 D.U.
Multi Family Residential (PA 14, PA16, PA17)	412 D.U.

Arboretum Specific Plan

Single Family Residential	963 D.U.
Multi Family Residential	2569 D.U.
City Parks	31.1 Acres
Recreation Center	26.83 TSF

Elementary School	400 Students
K - 8 School	800 Students

Ventana Specific Plan

Single Family Residential	504 D.U.
Multi Family Residential	338 D.U.
Retail Space	215.57 TSF
Office	362.93 TSF

Summit at Rosena Specific Plan

Single Family Residential	600 D.U.
---------------------------	----------

West Gate Specific Plan

Single Family Residential	826 D.U.
Multi-family Residential	2422 D.U.
Commercial/Retail Use	292.5 Acres
Industrial Warehouse	1114.27 TSF
High School	60 Acres
Elementary School	24 Acres
Public Parks	29.7 Acres
Private Parks	3.4 Acres

Jiffy Lube - ASP16-000014	4.69 TSF
----------------------------------	----------

Journey Community Church - DRP10-002	35.50 TSF
---	-----------

Sierra Lakes Shopping Center - ASP16-000050	
Retail	4.14 TSF

Sierra Lakes Shopping Center - ASP14-000042	
Animal Hospital	4.44 TSF

Sierra Lakes Shopping Center - ASP14-000031	
Retail Shops	6.18 TSF

Sierra Lakes Shopping Center - ASP16-000009	
Drive Thru Restaurant	6.11 TSF
Medical Office	10.69 TSF
Daycare Center	10.70 TSF

210 Sports Park

Baseball/Softball Fields	14
Concession/Meeting Space	8.00 TSF

South of the 210 FWY

Promenade Specific Plan

Single Family Residential	376 D.U.	50% occupied
Park/Rec Center	1.9 Acres	
Walmart	193.0 TSF	
Restaurant	12.0 TSF	
Retail Space	11.60 TSF	
Convenience Store and Gas Station with Car Wash	12 Fuel Pumps	
Fast Food Drive Thru	9.4 TSF	

Highland Village

Shopping Center	87.0 TSF	
Restaurant	6.0 TSF	
Medical Office	25 TSF	

Attachment F
Study Intersections and Scenarios

No.	Study Intersection	Study Scenario					
		Existing	Existing With Project	Opening Year Without Project	Opening Year With Project	Buildout (Year 2040) Without Project	Buildout (Year 2040) With Project
1	Coyote Canyon Rd. / Duncan Canyon Road			X	X	X	X
2	Lytle Creek Road / Duncan Canyon Road	X	X				
3	Project Driveway / Lytle Creek Road		X		X		X
4	Lytle Creek Road / Public Access Road		X		X		X
5	Sierra Avenue / Lytle Creek Road (Without Realignment)	X		X		X	
6	Sierra Avenue / Lytle Creek Road (With Realignment)		X		X		X
7	Sierra Avenue / I-15 SB Ramps	X	X	X	X	X	X
8	Sierra Avenue / I-15 NB Ramps	X	X	X	X	X	X
9	Sierra Avenue / Riverside Avenue	X	X	X	X	X	X

GENERAL NOTES:

- PROJECT SHALL BE DESIGNED TO MEET 2006 CALIFORNIA BUILDING STANDARDS CODE
- PROJECT SHALL ADHERE TO FONTANA MUNICIPAL CODE SECTION 16.04 FOR LANDSCAPE REQUIREMENTS
- PROJECT SHALL ADHERE TO FONTANA MUNICIPAL CODE SECTION 16.05 (2) FOR SCREENING REQUIREMENTS
- PROJECT SHALL ADHERE TO CITY OF FONTANA STANDARD OF ONE FOOT CANALS MINIMUM FOR ALL ENTRANCES, BOTH PEDESTRIAN PATHS, PARKING LOTS AND ACTIVITY AREAS. ALL AREAS SHALL BE ILLUMINATED DURING ALL HOURS OF DARKNESS AND ALL LUMINAIRES UTILIZED SHALL BE HAND-RESISTANT FINISHED. LIGHTING SHALL BE FLUORESCENT, WHITE LED OR METAL HALIDE.

LEGAL DESCRIPTION (CONTINUED)

OWNER:
 CAPROCK PARTNERS
 2005 MAIN STREET, SUITE 240
 BRINNE, CA 92514
 PHONE: (949) 340-5400
 FAX: (949) 340-5474

LANDSCAPE ARCHITECT:
 SCOTT PETERSON, ASLA
 5006 S. WILSON ROAD, STE 121
 BONNELL, CA 92003
 PHONE: 760.342.8900
 FAX: 909.337.8864

ARCHITECT:
 DOUGLASS FRANK ARCHITECTS
 4001 WESTERLY PLACE SUITE 108
 INDIOPORT BEACH, CA 92908
 PHONE: 949.553.2625
 FAX: 949.553.0960

CIVIL ENGINEER:
 STEVEN REELEY GROUP INC.
 575 E. CARBON DRIVE
 COLTON, CA 92534-0099
 PHONE: (800) 370-4911
 FAX: (800) 370-2171

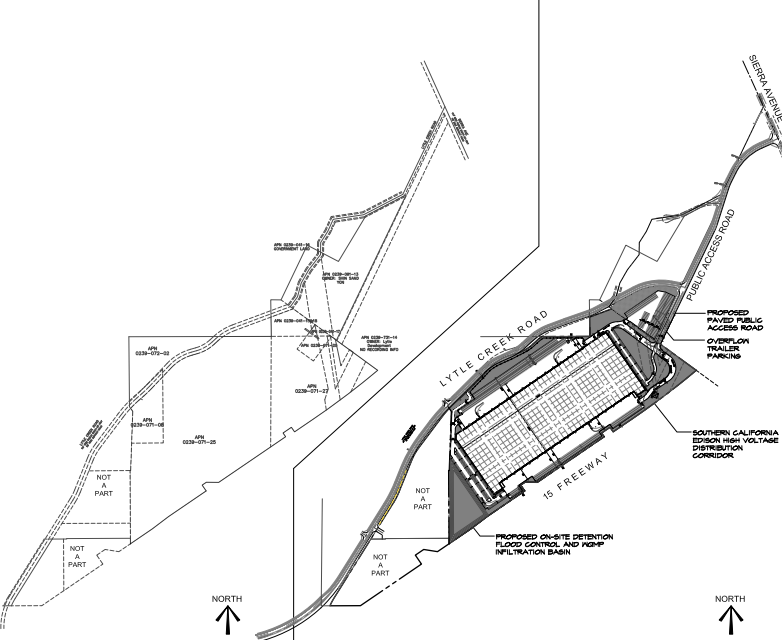

ZONING USE/OCCUPANCY:	M-2 GENERAL INDUSTRIAL WAREHOUSE (S-1) OFFICE (B)
CONSTRUCTION TYPE	V-B
CLEAR HEIGHT	38'-0"
SPRINKLERED	YES
SITE AREA:	2,884,434sf (61.17ac)
BUILDING AREA:	1,175,720sf
FAR	44.12%
PARKING REQUIRED	
OFFICE	30,000sf 1:250 120
WHSE	40,000sf 1:1000 40
WHSE	1,105,720sf 1:4000 276
TOTAL REQUIRED	1406
PARKING PROVIDED	
AUTOMOBILE PARKING STALLS	406
TRAILER STALLS PROVIDED	309
TOTAL PROVIDED	716
DOCK DOORS PROVIDED	199
LANDSCAPE REQUIRED (15%)	399,665sf
LANDSCAPE PROVIDED (23%)	627,205sf

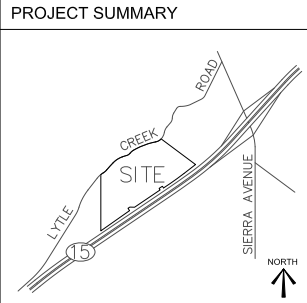

LEGAL DESCRIPTION

PROJECT TEAM

APN MAP

MASTER SITE PLAN

VICINITY MAP

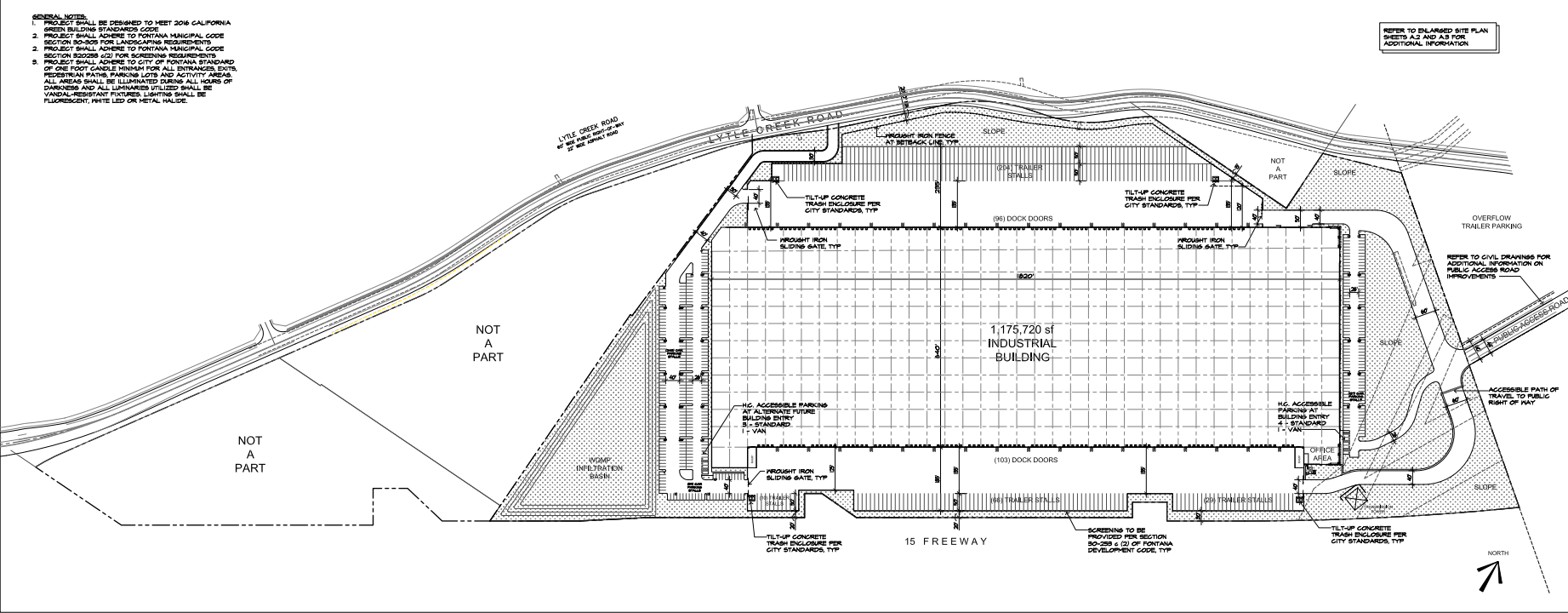

REVISIONS

NO.	DATE	DESCRIPTION

PRELIMINARY SITE PLAN

DATE: 02/26/17
 SCALE: 1" = 100'-0"
 DRAWN BY: DPA
 PROJECT NO: 13024.00

A.1
 OPTION 15

I-15 Logistics Center
 3935 Lytle Creek Road
 Fontana, CA (County of San Bernardino)

Appendix C: Existing Synchro Worksheets

This page intentionally left blank

Intersection

Int Delay, s/veh 0.2

Movement	EBL	EBT	WBT	WBR	SBL	SBR
Lane Configurations		↑↑	↑↑			↑
Traffic Vol, veh/h	0	434	118	3	0	15
Future Vol, veh/h	0	434	118	3	0	15
Conflicting Peds, #/hr	0	0	0	0	0	0
Sign Control	Free	Free	Free	Free	Stop	Stop
RT Channelized	-	None	-	None	-	None
Storage Length	-	-	-	-	-	0
Veh in Median Storage, #	-	0	0	-	0	-
Grade, %	-	0	0	-	0	-
Peak Hour Factor	94	94	94	94	94	94
Heavy Vehicles, %	0	0	0	0	0	0
Mvmt Flow	0	462	126	3	0	16

Major/Minor

	Major1	Major2	Minor2
Conflicting Flow All	-	0	-
Stage 1	-	-	-
Stage 2	-	-	-
Critical Hdwy	-	-	-
Critical Hdwy Stg 1	-	-	-
Critical Hdwy Stg 2	-	-	-
Follow-up Hdwy	-	-	-
Pot Cap-1 Maneuver	0	-	-
Stage 1	0	-	-
Stage 2	0	-	-
Platoon blocked, %	-	-	-
Mov Cap-1 Maneuver	-	-	-
Mov Cap-2 Maneuver	-	-	-
Stage 1	-	-	-
Stage 2	-	-	-

Approach

	EB	WB	SB
HCM Control Delay, s	0	0	8.7
HCM LOS			A

Minor Lane/Major Mvmt

	EBT	WBT	WBR	SBLn1
Capacity (veh/h)	-	-	-	994
HCM Lane V/C Ratio	-	-	-	0.016
HCM Control Delay (s)	-	-	-	8.7
HCM Lane LOS	-	-	-	A
HCM 95th %tile Q(veh)	-	-	-	0

Intersection						
Int Delay, s/veh	0.4					
Movement	EBL	EBR	NBL	NBT	SBT	SBR
Lane Configurations						
Traffic Vol, veh/h	4	10	17	291	882	13
Future Vol, veh/h	4	10	17	291	882	13
Conflicting Peds, #/hr	0	0	0	0	0	0
Sign Control	Stop	Stop	Free	Free	Free	Free
RT Channelized	-	None	-	None	-	None
Storage Length	0	-	120	-	-	-
Veh in Median Storage, #	0	-	-	0	0	-
Grade, %	0	-	-	0	0	-
Peak Hour Factor	84	84	84	84	84	84
Heavy Vehicles, %	0	0	0	0	0	0
Mvmt Flow	5	12	20	346	1050	15





















Major/Minor	Minor2	Major1	Major2			
Conflicting Flow All	1272	533	1065	0	-	0
Stage 1	1058	-	-	-	-	-
Stage 2	214	-	-	-	-	-
Critical Hdwy	6.8	6.9	4.1	-	-	-
Critical Hdwy Stg 1	5.8	-	-	-	-	-
Critical Hdwy Stg 2	5.8	-	-	-	-	-
Follow-up Hdwy	3.5	3.3	2.2	-	-	-
Pot Cap-1 Maneuver	162	496	662	-	-	-
Stage 1	299	-	-	-	-	-
Stage 2	807	-	-	-	-	-
Platoon blocked, %				-	-	-
Mov Cap-1 Maneuver	157	496	662	-	-	-
Mov Cap-2 Maneuver	157	-	-	-	-	-
Stage 1	299	-	-	-	-	-
Stage 2	783	-	-	-	-	-

Approach	EB	NB	SB
HCM Control Delay, s	17.4	0.6	0
HCM LOS	C		

Minor Lane/Major Mvmt	NBL	NBT	EBLn1	SBT	SBR
Capacity (veh/h)	662	-	307	-	-
HCM Lane V/C Ratio	0.031	-	0.054	-	-
HCM Control Delay (s)	10.6	-	17.4	-	-
HCM Lane LOS	B	-	C	-	-
HCM 95th %tile Q(veh)	0.1	-	0.2	-	-

HCM 2010 Signalized Intersection Summary
7: Sierra Ave & I-15 SB Ramps

Existing AM
03/16/2018

												
Movement	EBL	EBT	EBR	WBL	WBT	WBR	NBL	NBT	NBR	SBL	SBT	SBR
Lane Configurations												
Traffic Volume (veh/h)	0	0	0	455	0	138	400	390	0	0	349	741
Future Volume (veh/h)	0	0	0	455	0	138	400	390	0	0	349	741
Number				7	4	14	1	6	16	5	2	12
Initial Q (Qb), veh				0	0	0	0	0	0	0	0	0
Ped-Bike Adj(A_pbT)				1.00		1.00	1.00		1.00	1.00		1.00
Parking Bus, Adj				1.00	1.00	1.00	1.00	1.00	1.00	1.00	1.00	1.00
Adj Sat Flow, veh/h/ln				1900	1900	1900	1900	1900	0	0	1900	1900
Adj Flow Rate, veh/h				511	0	155	449	438	0	0	392	833
Adj No. of Lanes				2	0	1	1	2	0	0	2	1
Peak Hour Factor				0.89	0.89	0.89	0.89	0.89	0.89	0.89	0.89	0.89
Percent Heavy Veh, %				0	0	0	0	0	0	0	0	0
Cap, veh/h				694	0	310	259	2299	0	0	1525	682
Arrive On Green				0.19	0.00	0.19	0.24	1.00	0.00	0.00	0.42	0.42
Sat Flow, veh/h				3619	0	1615	1810	3705	0	0	3705	1615
Grp Volume(v), veh/h				511	0	155	449	438	0	0	392	833
Grp Sat Flow(s),veh/h/ln				1810	0	1615	1810	1805	0	0	1805	1615
Q Serve(g_s), s				9.3	0.0	6.0	10.0	0.0	0.0	0.0	4.9	29.6
Cycle Q Clear(g_c), s				9.3	0.0	6.0	10.0	0.0	0.0	0.0	4.9	29.6
Prop In Lane				1.00		1.00	1.00		0.00	0.00		1.00
Lane Grp Cap(c), veh/h				694	0	310	259	2299	0	0	1525	682
V/C Ratio(X)				0.74	0.00	0.50	1.74	0.19	0.00	0.00	0.26	1.22
Avail Cap(c_a), veh/h				1293	0	577	259	2299	0	0	1525	682
HCM Platoon Ratio				1.00	1.00	1.00	1.67	1.67	1.00	1.00	1.00	1.00
Upstream Filter(I)				1.00	0.00	1.00	0.93	0.93	0.00	0.00	1.00	1.00
Uniform Delay (d), s/veh				26.6	0.0	25.3	26.7	0.0	0.0	0.0	13.1	20.2
Incr Delay (d2), s/veh				1.5	0.0	1.2	346.2	0.2	0.0	0.0	0.4	112.3
Initial Q Delay(d3),s/veh				0.0	0.0	0.0	0.0	0.0	0.0	0.0	0.0	0.0
%ile BackOfQ(50%),veh/ln				4.8	0.0	2.8	29.8	0.1	0.0	0.0	2.5	34.4
LnGrp Delay(d),s/veh				28.2	0.0	26.5	372.9	0.2	0.0	0.0	13.5	132.6
LnGrp LOS				C		C	F	A			B	F
Approach Vol, veh/h					666			887			1225	
Approach Delay, s/veh					27.8			188.8			94.5	
Approach LOS					C			F			F	
Timer	1	2	3	4	5	6	7	8				
Assigned Phs	1	2		4		6						
Phs Duration (G+Y+Rc), s	15.0	35.6		19.4		50.6						
Change Period (Y+Rc), s	5.0	6.0		6.0		6.0						
Max Green Setting (Gmax), s	10.0	18.0		25.0		33.0						
Max Q Clear Time (g_c+I1), s	12.0	31.6		11.3		2.0						
Green Ext Time (p_c), s	0.0	0.0		2.1		11.7						
Intersection Summary												
HCM 2010 Ctrl Delay				108.6								
HCM 2010 LOS				F								
Notes												

HCM 2010 Signalized Intersection Summary

8: Sierra Ave & I-15 NB Ramps

Existing AM
03/16/2018



Movement	EBL	EBT	EBR	WBL	WBT	WBR	NBL	NBT	NBR	SBL	SBT	SBR
Lane Configurations												
Traffic Volume (veh/h)	217	0	180	0	0	0	0	573	201	64	740	0
Future Volume (veh/h)	217	0	180	0	0	0	0	573	201	64	740	0
Number	3	8	18				1	6	16	5	2	12
Initial Q (Qb), veh	0	0	0				0	0	0	0	0	0
Ped-Bike Adj(A_pbT)	1.00		1.00				1.00		1.00	1.00		1.00
Parking Bus, Adj	1.00	1.00	1.00				1.00	1.00	1.00	1.00	1.00	1.00
Adj Sat Flow, veh/h/ln	1900	1900	1900				0	1900	1900	1900	1900	0
Adj Flow Rate, veh/h	307	0	135				0	644	226	72	831	0
Adj No. of Lanes	2	0	1				0	2	1	1	2	0
Peak Hour Factor	0.89	0.89	0.89				0.89	0.89	0.89	0.89	0.89	0.89
Percent Heavy Veh, %	0	0	0				0	0	0	0	0	0
Cap, veh/h	414	0	185				0	2127	951	97	2579	0
Arrive On Green	0.11	0.00	0.11				0.00	0.59	0.59	0.11	1.00	0.00
Sat Flow, veh/h	3619	0	1615				0	3705	1615	1810	3705	0
Grp Volume(v), veh/h	307	0	135				0	644	226	72	831	0
Grp Sat Flow(s),veh/h/ln	1810	0	1615				0	1805	1615	1810	1805	0
Q Serve(g_s), s	5.7	0.0	5.7				0.0	6.2	4.7	2.7	0.0	0.0
Cycle Q Clear(g_c), s	5.7	0.0	5.7				0.0	6.2	4.7	2.7	0.0	0.0
Prop In Lane	1.00		1.00				0.00		1.00	1.00		0.00
Lane Grp Cap(c), veh/h	414	0	185				0	2127	951	97	2579	0
V/C Ratio(X)	0.74	0.00	0.73				0.00	0.30	0.24	0.74	0.32	0.00
Avail Cap(c_a), veh/h	465	0	208				0	2127	951	259	2579	0
HCM Platoon Ratio	1.00	1.00	1.00				1.00	1.00	1.00	2.00	2.00	1.00
Upstream Filter(I)	1.00	0.00	1.00				0.00	1.00	1.00	0.84	0.84	0.00
Uniform Delay (d), s/veh	30.0	0.0	30.0				0.0	7.2	6.9	30.8	0.0	0.0
Incr Delay (d2), s/veh	5.6	0.0	11.0				0.0	0.4	0.6	3.5	0.3	0.0
Initial Q Delay(d3),s/veh	0.0	0.0	0.0				0.0	0.0	0.0	0.0	0.0	0.0
%ile BackOfQ(50%),veh/ln	8.2	0.0	3.1				0.0	3.1	2.2	1.4	0.1	0.0
LnGrp Delay(d),s/veh	35.6	0.0	41.0				0.0	7.6	7.5	34.2	0.3	0.0
LnGrp LOS	D		D					A	A	C	A	
Approach Vol, veh/h		442						870			903	
Approach Delay, s/veh		37.2						7.5			3.0	
Approach LOS		D						A			A	
Timer	1	2	3	4	5	6	7	8				
Assigned Phs		2			5	6		8				
Phs Duration (G+Y+Rc), s		56.0			8.8	47.2		14.0				
Change Period (Y+Rc), s		6.0			5.0	6.0		6.0				
Max Green Setting (Gmax), s		49.0			10.0	34.0		9.0				
Max Q Clear Time (g_c+I1), s		2.0			4.7	8.2		7.7				
Green Ext Time (p_c), s		16.7			0.0	13.1		0.2				
Intersection Summary												
HCM 2010 Ctrl Delay			11.6									
HCM 2010 LOS			B									
Notes												

Intersection

Intersection Delay, s/veh60.8
Intersection LOS F

Movement	WBL	WBR	NBT	NBR	SBL	SBT
Lane Configurations						
Traffic Vol, veh/h	41	473	301	36	397	523
Future Vol, veh/h	41	473	301	36	397	523
Peak Hour Factor	0.92	0.92	0.92	0.92	0.92	0.92
Heavy Vehicles, %	0	0	0	0	0	0
Mvmt Flow	45	514	327	39	432	568
Number of Lanes	1	1	1	1	1	2

Approach	WB	NB	SB
Opposing Approach		SB	NB
Opposing Lanes	0	3	2
Conflicting Approach Left NB			WB
Conflicting Lanes Left	2	0	2
Conflicting Approach Right SB		WB	
Conflicting Lanes Right	3	2	0
HCM Control Delay	105.2	39.7	43.8
HCM LOS	F	E	E

Lane	NBLn1	NBLn2	WBLn1	WBLn2	SBLn1	SBLn2	SBLn3
Vol Left, %	0%	0%	100%	0%	100%	0%	0%
Vol Thru, %	100%	0%	0%	0%	0%	100%	100%
Vol Right, %	0%	100%	0%	100%	0%	0%	0%
Sign Control	Stop	Stop	Stop	Stop	Stop	Stop	Stop
Traffic Vol by Lane	301	36	41	473	397	262	262
LT Vol	0	0	41	0	397	0	0
Through Vol	301	0	0	0	0	262	262
RT Vol	0	36	0	473	0	0	0
Lane Flow Rate	327	39	45	514	432	284	284
Geometry Grp	8	8	8	8	8	8	8
Degree of Util (X)	0.816	0.09	0.112	1.138	1.002	0.621	0.487
Departure Headway (Hd)	9.514	8.78	9.293	7.971	8.921	8.402	6.639
Convergence, Y/N	Yes	Yes	Yes	Yes	Yes	Yes	Yes
Cap	383	410	388	452	410	432	546
Service Time	7.214	6.48	6.993	5.765	6.621	6.102	4.339
HCM Lane V/C Ratio	0.854	0.095	0.116	1.137	1.054	0.657	0.52
HCM Control Delay	43	12.3	13.2	113.2	75.5	23.9	15.5
HCM Lane LOS	E	B	B	F	F	C	C
HCM 95th-tile Q	7.3	0.3	0.4	18.2	12.4	4.1	2.6

Intersection						
Int Delay, s/veh	0.1					
Movement	EBL	EBT	WBT	WBR	SBL	SBR
Lane Configurations		↑↑	↑↑			↑
Traffic Vol, veh/h	0	243	385	13	0	6
Future Vol, veh/h	0	243	385	13	0	6
Conflicting Peds, #/hr	0	0	0	0	0	0
Sign Control	Free	Free	Free	Free	Stop	Stop
RT Channelized	-	None	-	None	-	None
Storage Length	-	-	-	-	-	0
Veh in Median Storage, #	-	0	0	-	0	-
Grade, %	-	0	0	-	0	-
Peak Hour Factor	90	90	90	90	90	90
Heavy Vehicles, %	0	0	0	0	0	0
Mvmt Flow	0	270	428	14	0	7

Major/Minor	Major1	Major2	Minor2		
Conflicting Flow All	-	0	-	0	221
Stage 1	-	-	-	-	-
Stage 2	-	-	-	-	-
Critical Hdwy	-	-	-	-	6.9
Critical Hdwy Stg 1	-	-	-	-	-
Critical Hdwy Stg 2	-	-	-	-	-
Follow-up Hdwy	-	-	-	-	3.3
Pot Cap-1 Maneuver	0	-	-	-	789
Stage 1	0	-	-	-	0
Stage 2	0	-	-	-	0
Platoon blocked, %	-	-	-	-	-
Mov Cap-1 Maneuver	-	-	-	-	789
Mov Cap-2 Maneuver	-	-	-	-	-
Stage 1	-	-	-	-	-
Stage 2	-	-	-	-	-

Approach	EB	WB	SB
HCM Control Delay, s	0	0	9.6
HCM LOS			A

Minor Lane/Major Mvmt	EBT	WBT	WBR	SBLn1
Capacity (veh/h)	-	-	-	789
HCM Lane V/C Ratio	-	-	-	0.008
HCM Control Delay (s)	-	-	-	9.6
HCM Lane LOS	-	-	-	A
HCM 95th %tile Q(veh)	-	-	-	0

Intersection						
Int Delay, s/veh	0.6					
Movement	EBL	EBR	NBL	NBT	SBT	SBR
Lane Configurations	↔		↔	↑↑	↑↑	
Traffic Vol, veh/h	14	23	24	608	403	3
Future Vol, veh/h	14	23	24	608	403	3
Conflicting Peds, #/hr	0	0	0	0	0	0
Sign Control	Stop	Stop	Free	Free	Free	Free
RT Channelized	-	None	-	None	-	None
Storage Length	0	-	120	-	-	-
Veh in Median Storage, #	0	-	-	0	0	-
Grade, %	0	-	-	0	0	-
Peak Hour Factor	95	95	95	95	95	95
Heavy Vehicles, %	0	0	0	0	0	0
Mvmt Flow	15	24	25	640	424	3



















Major/Minor	Minor2	Major1	Major2			
Conflicting Flow All	797	214	427	0	-	0
Stage 1	426	-	-	-	-	-
Stage 2	371	-	-	-	-	-
Critical Hdwy	6.8	6.9	4.1	-	-	-
Critical Hdwy Stg 1	5.8	-	-	-	-	-
Critical Hdwy Stg 2	5.8	-	-	-	-	-
Follow-up Hdwy	3.5	3.3	2.2	-	-	-
Pot Cap-1 Maneuver	328	797	1143	-	-	-
Stage 1	632	-	-	-	-	-
Stage 2	674	-	-	-	-	-
Platoon blocked, %				-	-	-
Mov Cap-1 Maneuver	321	797	1143	-	-	-
Mov Cap-2 Maneuver	321	-	-	-	-	-
Stage 1	632	-	-	-	-	-
Stage 2	659	-	-	-	-	-

Approach	EB	NB	SB
HCM Control Delay, s	12.6	0.3	0
HCM LOS	B		

Minor Lane/Major Mvmt	NBL	NBT	EBLn1	SBT	SBR
Capacity (veh/h)	1143	-	511	-	-
HCM Lane V/C Ratio	0.022	-	0.076	-	-
HCM Control Delay (s)	8.2	-	12.6	-	-
HCM Lane LOS	A	-	B	-	-
HCM 95th %tile Q(veh)	0.1	-	0.2	-	-

HCM 2010 Signalized Intersection Summary
7: Sierra Ave & I-15 SB Ramps

Existing PM
03/16/2018

												
Movement	EBL	EBT	EBR	WBL	WBT	WBR	NBL	NBT	NBR	SBL	SBT	SBR
Lane Configurations												
Traffic Volume (veh/h)	0	0	0	282	4	93	163	806	0	0	371	306
Future Volume (veh/h)	0	0	0	282	4	93	163	806	0	0	371	306
Number				7	4	14	1	6	16	5	2	12
Initial Q (Qb), veh				0	0	0	0	0	0	0	0	0
Ped-Bike Adj(A_pbT)				1.00		1.00	1.00		1.00	1.00		1.00
Parking Bus, Adj				1.00	1.00	1.00	1.00	1.00	1.00	1.00	1.00	1.00
Adj Sat Flow, veh/h/ln				1900	1900	1900	1900	1900	0	0	1900	1900
Adj Flow Rate, veh/h				306	0	100	175	867	0	0	399	329
Adj No. of Lanes				2	0	1	1	2	0	0	2	1
Peak Hour Factor				0.93	0.93	0.93	0.93	0.93	0.93	0.93	0.93	0.93
Percent Heavy Veh, %				0	0	0	0	0	0	0	0	0
Cap, veh/h				462	0	206	212	2530	0	0	1850	828
Arrive On Green				0.13	0.00	0.13	0.23	1.00	0.00	0.00	0.51	0.51
Sat Flow, veh/h				3619	0	1615	1810	3705	0	0	3705	1615
Grp Volume(v), veh/h				306	0	100	175	867	0	0	399	329
Grp Sat Flow(s),veh/h/ln				1810	0	1615	1810	1805	0	0	1805	1615
Q Serve(g_s), s				5.6	0.0	4.0	6.4	0.0	0.0	0.0	4.2	8.7
Cycle Q Clear(g_c), s				5.6	0.0	4.0	6.4	0.0	0.0	0.0	4.2	8.7
Prop In Lane				1.00		1.00	1.00		0.00	0.00		1.00
Lane Grp Cap(c), veh/h				462	0	206	212	2530	0	0	1850	828
V/C Ratio(X)				0.66	0.00	0.48	0.83	0.34	0.00	0.00	0.22	0.40
Avail Cap(c_a), veh/h				1293	0	577	259	2530	0	0	1850	828
HCM Platoon Ratio				1.00	1.00	1.00	2.00	2.00	1.00	1.00	1.00	1.00
Upstream Filter(I)				1.00	0.00	1.00	0.86	0.86	0.00	0.00	1.00	1.00
Uniform Delay (d), s/veh				29.1	0.0	28.4	26.1	0.0	0.0	0.0	9.4	10.4
Incr Delay (d2), s/veh				1.6	0.0	1.8	12.3	0.3	0.0	0.0	0.3	1.4
Initial Q Delay(d3),s/veh				0.0	0.0	0.0	0.0	0.0	0.0	0.0	0.0	0.0
%ile BackOfQ(50%),veh/ln				2.9	0.0	1.9	3.9	0.1	0.0	0.0	2.2	4.2
LnGrp Delay(d),s/veh				30.7	0.0	30.2	38.4	0.3	0.0	0.0	9.6	11.9
LnGrp LOS				C		C	D	A			A	B
Approach Vol, veh/h					406			1042			728	
Approach Delay, s/veh					30.6			6.7			10.6	
Approach LOS					C			A			B	
Timer	1	2	3	4	5	6	7	8				
Assigned Phs	1	2		4		6						
Phs Duration (G+Y+Rc), s	13.2	41.9		14.9		55.1						
Change Period (Y+Rc), s	5.0	6.0		6.0		6.0						
Max Green Setting (Gmax), s	10.0	18.0		25.0		33.0						
Max Q Clear Time (g_c+I1), s	8.4	10.7		7.6		2.0						
Green Ext Time (p_c), s	0.0	5.0		1.3		12.7						
Intersection Summary												
HCM 2010 Ctrl Delay				12.5								
HCM 2010 LOS				B								
Notes												

HCM 2010 Signalized Intersection Summary
8: Sierra Ave & I-15 NB Ramps

Existing PM
03/16/2018



Movement	EBL	EBT	EBR	WBL	WBT	WBR	NBL	NBT	NBR	SBL	SBT	SBR
Lane Configurations												
Traffic Volume (veh/h)	550	0	353	0	0	0	0	419	537	150	503	0
Future Volume (veh/h)	550	0	353	0	0	0	0	419	537	150	503	0
Number	3	8	18				1	6	16	5	2	12
Initial Q (Qb), veh	0	0	0				0	0	0	0	0	0
Ped-Bike Adj(A_pbT)	1.00		1.00				1.00		1.00	1.00		1.00
Parking Bus, Adj	1.00	1.00	1.00				1.00	1.00	1.00	1.00	1.00	1.00
Adj Sat Flow, veh/h/ln	1900	1900	1900				0	1900	1900	1900	1900	0
Adj Flow Rate, veh/h	717	0	256				0	455	584	163	547	0
Adj No. of Lanes	2	0	1				0	2	1	1	2	0
Peak Hour Factor	0.92	0.92	0.92				0.92	0.92	0.92	0.92	0.92	0.92
Percent Heavy Veh, %	0	0	0				0	0	0	0	0	0
Cap, veh/h	465	0	208				0	1865	834	202	2527	0
Arrive On Green	0.13	0.00	0.13				0.00	0.52	0.52	0.11	0.70	0.00
Sat Flow, veh/h	3619	0	1615				0	3705	1615	1810	3705	0
Grp Volume(v), veh/h	717	0	256				0	455	584	163	547	0
Grp Sat Flow(s),veh/h/ln	1810	0	1615				0	1805	1615	1810	1805	0
Q Serve(g_s), s	9.0	0.0	9.0				0.0	4.9	19.2	6.2	3.8	0.0
Cycle Q Clear(g_c), s	9.0	0.0	9.0				0.0	4.9	19.2	6.2	3.8	0.0
Prop In Lane	1.00		1.00				0.00		1.00	1.00		0.00
Lane Grp Cap(c), veh/h	465	0	208				0	1865	834	202	2527	0
V/C Ratio(X)	1.54	0.00	1.23				0.00	0.24	0.70	0.81	0.22	0.00
Avail Cap(c_a), veh/h	465	0	208				0	1865	834	233	2527	0
HCM Platoon Ratio	1.00	1.00	1.00				1.00	1.00	1.00	1.00	1.00	1.00
Upstream Filter(I)	1.00	0.00	1.00				0.00	1.00	1.00	0.95	0.95	0.00
Uniform Delay (d), s/veh	30.5	0.0	30.5				0.0	9.4	12.8	30.3	3.7	0.0
Incr Delay (d2), s/veh	254.0	0.0	139.3				0.0	0.3	4.9	13.6	0.2	0.0
Initial Q Delay(d3),s/veh	0.0	0.0	0.0				0.0	0.0	0.0	0.0	0.0	0.0
%ile BackOfQ(50%),veh/ln	20.9	0.0	12.0				0.0	2.5	9.6	3.8	1.9	0.0
LnGrp Delay(d),s/veh	284.5	0.0	169.8				0.0	9.7	17.7	44.0	3.9	0.0
LnGrp LOS	F		F					A	B	D	A	
Approach Vol, veh/h		973						1039			710	
Approach Delay, s/veh		254.3						14.2			13.1	
Approach LOS		F						B			B	
Timer	1	2	3	4	5	6	7	8				
Assigned Phs		2			5	6		8				
Phs Duration (G+Y+Rc), s		55.0			12.8	42.2		15.0				
Change Period (Y+Rc), s		6.0			5.0	6.0		6.0				
Max Green Setting (Gmax), s		49.0			9.0	35.0		9.0				
Max Q Clear Time (g_c+1), s		5.8			8.2	21.2		11.0				
Green Ext Time (p_c), s		12.5			0.0	7.6		0.0				
Intersection Summary												
HCM 2010 Ctrl Delay			99.7									
HCM 2010 LOS			F									
Notes												

Intersection

Intersection Delay, s/veh	109.7
Intersection LOS	F





















Movement	WBL	WBR	NBT	NBR	SBL	SBT
Lane Configurations						
Traffic Vol, veh/h	20	439	517	19	462	394
Future Vol, veh/h	20	439	517	19	462	394
Peak Hour Factor	0.94	0.94	0.94	0.94	0.94	0.94
Heavy Vehicles, %	0	0	0	0	0	0
Mvmt Flow	21	467	550	20	491	419
Number of Lanes	1	1	1	1	1	2

Approach	WB	NB	SB
Opposing Approach		SB	NB
Opposing Lanes	0	3	2
Conflicting Approach Left NB			WB
Conflicting Lanes Left	2	0	2
Conflicting Approach Right SB		WB	
Conflicting Lanes Right	3	2	0
HCM Control Delay	80.1	182.3	80.1
HCM LOS	F	F	F

Lane	NBLn1	NBLn2	WBLn1	WBLn2	SBLn1	SBLn2	SBLn3
Vol Left, %	0%	0%	100%	0%	100%	0%	0%
Vol Thru, %	100%	0%	0%	0%	0%	100%	100%
Vol Right, %	0%	100%	0%	100%	0%	0%	0%
Sign Control	Stop	Stop	Stop	Stop	Stop	Stop	Stop
Traffic Vol by Lane	517	19	20	439	462	197	197
LT Vol	0	0	20	0	462	0	0
Through Vol	517	0	0	0	0	197	197
RT Vol	0	19	0	439	0	0	0
Lane Flow Rate	550	20	21	467	491	210	210
Geometry Grp	8	8	8	8	8	8	8
Degree of Util (X)	1.324	0.045	0.054	1.032	1.18	0.474	0.375
Departure Headway (Hd)	9.178	8.446	10.056	8.807	9.426	8.904	7.129
Convergence, Y/N	Yes	Yes	Yes	Yes	Yes	Yes	Yes
Cap	402	426	358	416	388	407	507
Service Time	6.878	6.146	7.756	6.507	7.126	6.604	4.829
HCM Lane V/C Ratio	1.368	0.047	0.059	1.123	1.265	0.516	0.414
HCM Control Delay	188.6	11.5	13.3	83.1	134.1	19.4	14
HCM Lane LOS	F	B	B	F	F	C	B
HCM 95th-tile Q	24	0.1	0.2	13.4	18	2.5	1.7

HCM 2010 Signalized Intersection Summary
 8: Sierra Ave & I-15 NB Ramps

Existing PM
 03/19/2018

												
Movement	EBL	EBT	EBR	WBL	WBT	WBR	NBL	NBT	NBR	SBL	SBT	SBR
Lane Configurations												
Traffic Volume (veh/h)	550	0	353	0	0	0	0	419	537	150	503	0
Future Volume (veh/h)	550	0	353	0	0	0	0	419	537	150	503	0
Number	3	8	18				1	6	16	5	2	12
Initial Q (Qb), veh	0	0	0				0	0	0	0	0	0
Ped-Bike Adj(A_pbT)	1.00		1.00				1.00		1.00	1.00		1.00
Parking Bus, Adj	1.00	1.00	1.00				1.00	1.00	1.00	1.00	1.00	1.00
Adj Sat Flow, veh/h/ln	1900	1900	1900				0	1900	1900	1900	1900	0
Adj Flow Rate, veh/h	717	0	256				0	455	584	163	547	0
Adj No. of Lanes	2	0	1				0	2	1	1	2	0
Peak Hour Factor	0.92	0.92	0.92				0.92	0.92	0.92	0.92	0.92	0.92
Percent Heavy Veh, %	0	0	0				0	0	0	0	0	0
Cap, veh/h	848	0	378				0	1489	666	200	2145	0
Arrive On Green	0.23	0.00	0.23				0.00	0.41	0.41	0.22	1.00	0.00
Sat Flow, veh/h	3619	0	1615				0	3705	1615	1810	3705	0
Grp Volume(v), veh/h	717	0	256				0	455	584	163	547	0
Grp Sat Flow(s),veh/h/ln	1810	0	1615				0	1805	1615	1810	1805	0
Q Serve(g_s), s	13.2	0.0	10.1				0.0	5.9	23.3	6.0	0.0	0.0
Cycle Q Clear(g_c), s	13.2	0.0	10.1				0.0	5.9	23.3	6.0	0.0	0.0
Prop In Lane	1.00		1.00				0.00		1.00	1.00		0.00
Lane Grp Cap(c), veh/h	848	0	378				0	1489	666	200	2145	0
V/C Ratio(X)	0.85	0.00	0.68				0.00	0.31	0.88	0.82	0.25	0.00
Avail Cap(c_a), veh/h	931	0	415				0	1489	666	310	2145	0
HCM Platoon Ratio	1.00	1.00	1.00				1.00	1.00	1.00	2.00	2.00	1.00
Upstream Filter(I)	1.00	0.00	1.00				0.00	1.00	1.00	0.95	0.95	0.00
Uniform Delay (d), s/veh	25.6	0.0	24.4				0.0	13.8	18.9	26.6	0.0	0.0
Incr Delay (d2), s/veh	6.8	0.0	3.9				0.0	0.5	15.1	4.6	0.3	0.0
Initial Q Delay(d3),s/veh	0.0	0.0	0.0				0.0	0.0	0.0	0.0	0.0	0.0
%ile BackOfQ(50%),veh/ln	7.4	0.0	4.9				0.0	3.0	13.0	3.2	0.1	0.0
LnGrp Delay(d),s/veh	32.4	0.0	28.2				0.0	14.4	34.1	31.2	0.3	0.0
LnGrp LOS	C		C					B	C	C	A	
Approach Vol, veh/h		973						1039			710	
Approach Delay, s/veh		31.3						25.4			7.4	
Approach LOS		C						C			A	
Timer	1	2	3	4	5	6	7	8				
Assigned Phs		2			5	6		8				
Phs Duration (G+Y+Rc), s		47.6			12.7	34.9		22.4				
Change Period (Y+Rc), s		6.0			5.0	6.0		6.0				
Max Green Setting (Gmax), s		40.0			12.0	23.0		18.0				
Max Q Clear Time (g_c+I1), s		2.0			8.0	25.3		15.2				
Green Ext Time (p_c), s		12.1			0.1	0.0		1.2				
Intersection Summary												
HCM 2010 Ctrl Delay			22.8									
HCM 2010 LOS			C									
Notes												
User approved volume balancing among the lanes for turning movement.												

Appendix D: Existing With Project Synchro Worksheets

This page intentionally left blank

Intersection

Int Delay, s/veh 0.3

Movement	EBL	EBT	WBT	WBR	SBL	SBR
Lane Configurations		↑↑	↑↑			↑
Traffic Vol, veh/h	0	434	118	22	0	21
Future Vol, veh/h	0	434	118	22	0	21
Conflicting Peds, #/hr	0	0	0	0	0	0
Sign Control	Free	Free	Free	Free	Stop	Stop
RT Channelized	-	None	-	None	-	None
Storage Length	-	-	-	-	-	0
Veh in Median Storage, #	-	0	0	-	0	-
Grade, %	-	0	0	-	0	-
Peak Hour Factor	94	94	94	94	94	94
Heavy Vehicles, %	0	0	0	0	0	0
Mvmt Flow	0	462	126	23	0	22

Major/Minor

	Major1	Major2	Minor2
Conflicting Flow All	-	0	-
Stage 1	-	-	-
Stage 2	-	-	-
Critical Hdwy	-	-	-
Critical Hdwy Stg 1	-	-	-
Critical Hdwy Stg 2	-	-	-
Follow-up Hdwy	-	-	-
Pot Cap-1 Maneuver	0	-	-
Stage 1	0	-	-
Stage 2	0	-	-
Platoon blocked, %	-	-	-
Mov Cap-1 Maneuver	-	-	-
Mov Cap-2 Maneuver	-	-	-
Stage 1	-	-	-
Stage 2	-	-	-

Approach

	EB	WB	SB
HCM Control Delay, s	0	0	8.8
HCM LOS			A

Minor Lane/Major Mvmt

	EBT	WBT	WBR	SBLn1
Capacity (veh/h)	-	-	-	979
HCM Lane V/C Ratio	-	-	-	0.023
HCM Control Delay (s)	-	-	-	8.8
HCM Lane LOS	-	-	-	A
HCM 95th %tile Q(veh)	-	-	-	0.1

Intersection

Int Delay, s/veh 4.7

Movement EBT EBR WBL WBT NBL NBR

Lane Configurations						
Traffic Vol, veh/h	14	19	51	15	6	15
Future Vol, veh/h	14	19	51	15	6	15
Conflicting Peds, #/hr	0	0	0	0	0	0
Sign Control	Free	Free	Free	Free	Stop	Stop
RT Channelized	-	None	-	None	-	None
Storage Length	-	-	-	-	0	-
Veh in Median Storage, #	0	-	-	0	0	-
Grade, %	0	-	-	0	0	-
Peak Hour Factor	95	95	95	95	95	95
Heavy Vehicles, %	0	0	0	0	0	0
Mvmt Flow	15	20	54	16	6	16

Major/Minor Major1 Major2 Minor1

Conflicting Flow All	0	0	35	0	148	25
Stage 1	-	-	-	-	25	-
Stage 2	-	-	-	-	123	-
Critical Hdwy	-	-	4.1	-	6.4	6.2
Critical Hdwy Stg 1	-	-	-	-	5.4	-
Critical Hdwy Stg 2	-	-	-	-	5.4	-
Follow-up Hdwy	-	-	2.2	-	3.5	3.3
Pot Cap-1 Maneuver	-	-	1589	-	849	1057
Stage 1	-	-	-	-	1003	-
Stage 2	-	-	-	-	907	-
Platoon blocked, %	-	-	-	-	-	-
Mov Cap-1 Maneuver	-	-	1589	-	820	1057
Mov Cap-2 Maneuver	-	-	-	-	820	-
Stage 1	-	-	-	-	1003	-
Stage 2	-	-	-	-	876	-

Approach EB WB NB

HCM Control Delay, s	0	5.7	8.8
HCM LOS			A

Minor Lane/Major Mvmt NBLn1 EBT EBR WBL WBT

Capacity (veh/h)	976	-	-	1589	-
HCM Lane V/C Ratio	0.023	-	-	0.034	-
HCM Control Delay (s)	8.8	-	-	7.3	0
HCM Lane LOS	A	-	-	A	A
HCM 95th %tile Q(veh)	0.1	-	-	0.1	-

Intersection

Int Delay, s/veh 0.5

Movement	EBL	EBT	WBT	WBR	SBL	SBR
Lane Configurations		↶	↷		↶	
Traffic Vol, veh/h	0	65	177	51	15	0
Future Vol, veh/h	0	65	177	51	15	0
Conflicting Peds, #/hr	0	0	0	0	0	0
Sign Control	Free	Free	Free	Free	Stop	Stop
RT Channelized	-	None	-	None	-	None
Storage Length	-	-	-	-	0	-
Veh in Median Storage, #	-	0	0	-	0	-
Grade, %	-	0	0	-	0	-
Peak Hour Factor	95	95	95	95	95	95
Heavy Vehicles, %	0	0	0	0	0	0
Mvmt Flow	0	68	186	54	16	0

Major/Minor

	Major1	Major2	Minor2		
Conflicting Flow All	240	0	0	281	213
Stage 1	-	-	-	213	-
Stage 2	-	-	-	68	-
Critical Hdwy	4.1	-	-	6.4	6.2
Critical Hdwy Stg 1	-	-	-	5.4	-
Critical Hdwy Stg 2	-	-	-	5.4	-
Follow-up Hdwy	2.2	-	-	3.5	3.3
Pot Cap-1 Maneuver	1339	-	-	713	832
Stage 1	-	-	-	827	-
Stage 2	-	-	-	960	-
Platoon blocked, %		-	-		
Mov Cap-1 Maneuver	1339	-	-	713	832
Mov Cap-2 Maneuver	-	-	-	713	-
Stage 1	-	-	-	827	-
Stage 2	-	-	-	960	-

Approach











	EB	WB	SB
HCM Control Delay, s	0	0	10.2
HCM LOS			B

Minor Lane/Major Mvmt

	EBL	EBT	WBT	WBR	SBLn1
Capacity (veh/h)	1339	-	-	-	713
HCM Lane V/C Ratio	-	-	-	-	0.022
HCM Control Delay (s)	0	-	-	-	10.2
HCM Lane LOS	A	-	-	-	B
HCM 95th %tile Q(veh)	0	-	-	-	0.1

HCM 2010 Signalized Intersection Summary
 6: Sierra Ave & Lytle Creek Rd (W/ Realignment)

Existing W/ Project AM
 03/16/2018

								
Movement	EBL	EBR	NBL	NBT	SBT	SBR		
Lane Configurations								
Traffic Volume (veh/h)	2	67	210	306	890	18		
Future Volume (veh/h)	2	67	210	306	890	18		
Number	3	18	1	6	2	12		
Initial Q (Qb), veh	0	0	0	0	0	0		
Ped-Bike Adj(A_pbT)	1.00	1.00	1.00			1.00		
Parking Bus, Adj	1.00	1.00	1.00	1.00	1.00	1.00		
Adj Sat Flow, veh/h/ln	1900	1900	1900	1900	1900	1900		
Adj Flow Rate, veh/h	2	80	250	364	1060	21		
Adj No. of Lanes	0	0	1	2	2	0		
Peak Hour Factor	0.84	0.84	0.84	0.84	0.84	0.84		
Percent Heavy Veh, %	0	0	0	0	0	0		
Cap, veh/h	4	172	308	2341	1368	27		
Arrive On Green	0.11	0.11	0.17	0.65	0.38	0.38		
Sat Flow, veh/h	39	1564	1810	3705	3716	72		
Grp Volume(v), veh/h	83	0	250	364	528	553		
Grp Sat Flow(s),veh/h/ln	1622	0	1810	1805	1805	1887		
Q Serve(g_s), s	2.4	0.0	6.6	2.0	12.8	12.8		
Cycle Q Clear(g_c), s	2.4	0.0	6.6	2.0	12.8	12.8		
Prop In Lane	0.02	0.96	1.00			0.04		
Lane Grp Cap(c), veh/h	178	0	308	2341	682	713		
V/C Ratio(X)	0.47	0.00	0.81	0.16	0.77	0.77		
Avail Cap(c_a), veh/h	539	0	364	2580	745	779		
HCM Platoon Ratio	1.00	1.00	1.00	1.00	1.00	1.00		
Upstream Filter(I)	1.00	0.00	1.00	1.00	1.00	1.00		
Uniform Delay (d), s/veh	20.7	0.0	19.9	3.4	13.6	13.6		
Incr Delay (d2), s/veh	1.9	0.0	11.4	0.0	4.7	4.5		
Initial Q Delay(d3),s/veh	0.0	0.0	0.0	0.0	0.0	0.0		
%ile BackOfQ(50%),veh/ln	1.2	0.0	4.2	1.0	7.2	7.5		
LnGrp Delay(d),s/veh	22.6	0.0	31.2	3.4	18.3	18.1		
LnGrp LOS	C		C	A	B	B		
Approach Vol, veh/h	83			614	1081			
Approach Delay, s/veh	22.6			14.8	18.2			
Approach LOS	C			B	B			
Timer	1	2	3	4	5	6	7	8
Assigned Phs	1	2				6		8
Phs Duration (G+Y+Rc), s	13.4	24.8				38.2		11.5
Change Period (Y+Rc), s	5.0	6.0				6.0		6.0
Max Green Setting (Gmax), s	10.0	20.5				35.5		16.5
Max Q Clear Time (g_c+I1), s	8.6	14.8				4.0		4.4
Green Ext Time (p_c), s	0.1	4.0				12.2		0.1
Intersection Summary								
HCM 2010 Ctrl Delay			17.2					
HCM 2010 LOS			B					
Notes								

HCM 2010 Signalized Intersection Summary
 7: Sierra Ave & I-15 SB Ramps

Existing W/ Project AM
 03/16/2018



Movement	EBL	EBT	EBR	WBL	WBT	WBR	NBL	NBT	NBR	SBL	SBT	SBR
Lane Configurations				↖	↖	↖	↖	↕			↕	↖
Traffic Volume (veh/h)	0	0	0	455	0	214	400	522	0	0	384	771
Future Volume (veh/h)	0	0	0	455	0	214	400	522	0	0	384	771
Number				7	4	14	1	6	16	5	2	12
Initial Q (Qb), veh				0	0	0	0	0	0	0	0	0
Ped-Bike Adj(A_pbT)				1.00		1.00	1.00		1.00	1.00		1.00
Parking Bus, Adj				1.00	1.00	1.00	1.00	1.00	1.00	1.00	1.00	1.00
Adj Sat Flow, veh/h/ln				1900	1900	1900	1900	1900	0	0	1900	1900
Adj Flow Rate, veh/h				511	0	240	449	587	0	0	431	866
Adj No. of Lanes				2	0	1	1	2	0	0	2	1
Peak Hour Factor				0.89	0.89	0.89	0.89	0.89	0.89	0.89	0.89	0.89
Percent Heavy Veh, %				0	0	0	0	0	0	0	0	0
Cap, veh/h				731	0	326	259	2262	0	0	1488	666
Arrive On Green				0.20	0.00	0.20	0.19	0.83	0.00	0.00	0.41	0.41
Sat Flow, veh/h				3619	0	1615	1810	3705	0	0	3705	1615
Grp Volume(v), veh/h				511	0	240	449	587	0	0	431	866
Grp Sat Flow(s),veh/h/ln				1810	0	1615	1810	1805	0	0	1805	1615
Q Serve(g_s), s				9.2	0.0	9.7	10.0	2.4	0.0	0.0	5.6	28.9
Cycle Q Clear(g_c), s				9.2	0.0	9.7	10.0	2.4	0.0	0.0	5.6	28.9
Prop In Lane				1.00		1.00	1.00		0.00	0.00		1.00
Lane Grp Cap(c), veh/h				731	0	326	259	2262	0	0	1488	666
V/C Ratio(X)				0.70	0.00	0.74	1.74	0.26	0.00	0.00	0.29	1.30
Avail Cap(c_a), veh/h				1293	0	577	259	2262	0	0	1488	666
HCM Platoon Ratio				1.00	1.00	1.00	1.33	1.33	1.00	1.00	1.00	1.00
Upstream Filter(I)				1.00	0.00	1.00	0.90	0.90	0.00	0.00	0.66	0.66
Uniform Delay (d), s/veh				25.9	0.0	26.2	28.3	2.4	0.0	0.0	13.7	20.6
Incr Delay (d2), s/veh				1.2	0.0	3.2	345.8	0.3	0.0	0.0	0.3	142.7
Initial Q Delay(d3),s/veh				0.0	0.0	0.0	0.0	0.0	0.0	0.0	0.0	0.0
%ile BackOfQ(50%),veh/ln				4.7	0.0	4.6	29.8	1.2	0.0	0.0	2.8	39.1
LnGrp Delay(d),s/veh				27.2	0.0	29.4	374.2	2.6	0.0	0.0	14.1	163.2
LnGrp LOS				C		C	F	A			B	F
Approach Vol, veh/h					751			1036			1297	
Approach Delay, s/veh					27.9			163.7			113.7	
Approach LOS					C			F			F	
Timer	1	2	3	4	5	6	7	8				
Assigned Phs	1	2		4		6						
Phs Duration (G+Y+Rc), s	5.0	34.9		20.1		49.9						
Change Period (Y+Rc), s	5.0	6.0		6.0		6.0						
Max Green Setting (Gmax), s	10.0	18.0		25.0		33.0						
Max Q Clear Time (g_c+M2), s	10.0	30.9		11.7		4.4						
Green Ext Time (p_c), s	0.0	0.0		2.4		13.7						
Intersection Summary												
HCM 2010 Ctrl Delay				109.6								
HCM 2010 LOS				F								
Notes												

HCM 2010 Signalized Intersection Summary
 8: Sierra Ave & I-15 NB Ramps

Existing W/ Project AM
 03/16/2018



Movement	EBL	EBT	EBR	WBL	WBT	WBR	NBL	NBT	NBR	SBL	SBT	SBR
Lane Configurations												
Traffic Volume (veh/h)	312	0	180	0	0	0	0	610	201	88	751	0
Future Volume (veh/h)	312	0	180	0	0	0	0	610	201	88	751	0
Number	3	8	18				1	6	16	5	2	12
Initial Q (Qb), veh	0	0	0				0	0	0	0	0	0
Ped-Bike Adj(A_pbT)	1.00		1.00				1.00		1.00	1.00		1.00
Parking Bus, Adj	1.00	1.00	1.00				1.00	1.00	1.00	1.00	1.00	1.00
Adj Sat Flow, veh/h/ln	1900	1900	1900				0	1900	1900	1900	1900	0
Adj Flow Rate, veh/h	414	0	135				0	685	226	99	844	0
Adj No. of Lanes	2	0	1				0	2	1	1	2	0
Peak Hour Factor	0.89	0.89	0.89				0.89	0.89	0.89	0.89	0.89	0.89
Percent Heavy Veh, %	0	0	0				0	0	0	0	0	0
Cap, veh/h	465	0	208				0	2014	901	128	2527	0
Arrive On Green	0.13	0.00	0.13				0.00	0.56	0.56	0.09	0.93	0.00
Sat Flow, veh/h	3619	0	1615				0	3705	1615	1810	3705	0
Grp Volume(v), veh/h	414	0	135				0	685	226	99	844	0
Grp Sat Flow(s),veh/h/ln	1810	0	1615				0	1805	1615	1810	1805	0
Q Serve(g_s), s	7.9	0.0	5.6				0.0	7.2	5.0	3.7	1.6	0.0
Cycle Q Clear(g_c), s	7.9	0.0	5.6				0.0	7.2	5.0	3.7	1.6	0.0
Prop In Lane	1.00		1.00				0.00		1.00	1.00		0.00
Lane Grp Cap(c), veh/h	465	0	208				0	2014	901	128	2527	0
V/C Ratio(X)	0.89	0.00	0.65				0.00	0.34	0.25	0.78	0.33	0.00
Avail Cap(c_a), veh/h	465	0	208				0	2014	901	259	2527	0
HCM Platoon Ratio	1.00	1.00	1.00				1.00	1.00	1.00	1.33	1.33	1.00
Upstream Filter(I)	1.00	0.00	1.00				0.00	1.00	1.00	0.83	0.83	0.00
Uniform Delay (d), s/veh	30.0	0.0	29.0				0.0	8.4	7.9	31.2	0.8	0.0
Incr Delay (d2), s/veh	18.7	0.0	7.0				0.0	0.5	0.7	3.2	0.3	0.0
Initial Q Delay(d3),s/veh	0.0	0.0	0.0				0.0	0.0	0.0	0.0	0.0	0.0
%ile BackOfQ(50%),veh/ln	5.1	0.0	2.9				0.0	3.7	2.4	2.0	0.8	0.0
LnGrp Delay(d),s/veh	48.8	0.0	36.0				0.0	8.9	8.6	34.3	1.1	0.0
LnGrp LOS	D		D					A	A	C	A	
Approach Vol, veh/h		549						911			943	
Approach Delay, s/veh		45.6						8.8			4.6	
Approach LOS		D						A			A	
Timer	1	2	3	4	5	6	7	8				
Assigned Phs		2			5	6		8				
Phs Duration (G+Y+Rc), s		55.0			9.9	45.1		15.0				
Change Period (Y+Rc), s		6.0			5.0	6.0		6.0				
Max Green Setting (Gmax), s		49.0			10.0	34.0		9.0				
Max Q Clear Time (g_c+I1), s		3.6			5.7	9.2		9.9				
Green Ext Time (p_c), s		17.3			0.0	13.3		0.0				
Intersection Summary												
HCM 2010 Ctrl Delay			15.6									
HCM 2010 LOS			B									
Notes												

Intersection

Intersection Delay, s/veh 70.3

Intersection LOS F

Movement	WBL	WBR	NBT	NBR	SBL	SBT
Lane Configurations	↘	↗	↑	↗	↘	↑↑
Traffic Vol, veh/h	41	497	314	36	404	527
Future Vol, veh/h	41	497	314	36	404	527
Peak Hour Factor	0.92	0.92	0.92	0.92	0.92	0.92
Heavy Vehicles, %	0	0	0	0	0	0
Mvmt Flow	45	540	341	39	439	573
Number of Lanes	1	1	1	1	1	2

Approach	WB	NB	SB
Opposing Approach		SB	NB
Opposing Lanes	0	3	2
Conflicting Approach Left NB			WB
Conflicting Lanes Left	2	0	2
Conflicting Approach Right SB		WB	
Conflicting Lanes Right	3	2	0
HCM Control Delay	126.6	43.9	47.7
HCM LOS	F	E	E

Lane	NBLn1	NBLn2	WBLn1	WBLn2	SBLn1	SBLn2	SBLn3
Vol Left, %	0%	0%	100%	0%	100%	0%	0%
Vol Thru, %	100%	0%	0%	0%	0%	100%	100%
Vol Right, %	0%	100%	0%	100%	0%	0%	0%
Sign Control	Stop	Stop	Stop	Stop	Stop	Stop	Stop
Traffic Vol by Lane	314	36	41	497	404	264	264
LT Vol	0	0	41	0	404	0	0
Through Vol	314	0	0	0	0	264	264
RT Vol	0	36	0	497	0	0	0
Lane Flow Rate	341	39	45	540	439	286	286
Geometry Grp	8	8	8	8	8	8	8
Degree of Util (X)	0.845	0.089	0.114	1.2	1.028	0.631	0.496
Departure Headway (Hd)	9.694	8.958	9.381	8.152	9.093	8.573	6.806
Convergence, Y/N	Yes	Yes	Yes	Yes	Yes	Yes	Yes
Cap	375	403	385	448	404	424	533
Service Time	7.394	6.658	7.081	5.852	6.793	6.273	4.506
HCM Lane V/C Ratio	0.909	0.097	0.117	1.205	1.087	0.675	0.537
HCM Control Delay	47.5	12.5	13.3	136	83.3	24.8	16
HCM Lane LOS	E	B	B	F	F	C	C
HCM 95th-tile Q	7.8	0.3	0.4	20.7	13.1	4.2	2.7

Intersection

Int Delay, s/veh 0.4

Movement	EBL	EBT	WBT	WBR	SBL	SBR
Lane Configurations		↑↑	↑↑			↑
Traffic Vol, veh/h	0	243	385	21	0	26
Future Vol, veh/h	0	243	385	21	0	26
Conflicting Peds, #/hr	0	0	0	0	0	0
Sign Control	Free	Free	Free	Free	Stop	Stop
RT Channelized	-	None	-	None	-	None
Storage Length	-	-	-	-	-	0
Veh in Median Storage, #	-	0	0	-	0	-
Grade, %	-	0	0	-	0	-
Peak Hour Factor	90	90	90	90	90	90
Heavy Vehicles, %	0	0	0	0	0	0
Mvmt Flow	0	270	428	23	0	29

Major/Minor

	Major1	Major2	Minor2
Conflicting Flow All	-	0	-
Stage 1	-	-	-
Stage 2	-	-	-
Critical Hdwy	-	-	-
Critical Hdwy Stg 1	-	-	-
Critical Hdwy Stg 2	-	-	-
Follow-up Hdwy	-	-	-
Pot Cap-1 Maneuver	0	-	-
Stage 1	0	-	-
Stage 2	0	-	-
Platoon blocked, %	-	-	-
Mov Cap-1 Maneuver	-	-	-
Mov Cap-2 Maneuver	-	-	-
Stage 1	-	-	-
Stage 2	-	-	-

Approach

	EB	WB	SB
HCM Control Delay, s	0	0	9.8
HCM LOS			A

Minor Lane/Major Mvmt

	EBT	WBT	WBR	SBLn1
Capacity (veh/h)	-	-	-	783
HCM Lane V/C Ratio	-	-	-	0.037
HCM Control Delay (s)	-	-	-	9.8
HCM Lane LOS	-	-	-	A
HCM 95th %tile Q(veh)	-	-	-	0.1

Intersection

Int Delay, s/veh 5.5

Movement EBT EBR WBL WBT NBL NBR

Lane Configurations						
Traffic Vol, veh/h	37	8	20	6	20	54
Future Vol, veh/h	37	8	20	6	20	54
Conflicting Peds, #/hr	0	0	0	0	0	0
Sign Control	Free	Free	Free	Free	Stop	Stop
RT Channelized	-	None	-	None	-	None
Storage Length	-	-	-	-	0	-
Veh in Median Storage, #	0	-	-	0	0	-
Grade, %	0	-	-	0	0	-
Peak Hour Factor	95	95	95	95	95	95
Heavy Vehicles, %	0	0	0	0	0	0
Mvmt Flow	39	8	21	6	21	57

Major/Minor Major1 Major2 Minor1

Conflicting Flow All	0	0	47	0	91	43
Stage 1	-	-	-	-	43	-
Stage 2	-	-	-	-	48	-
Critical Hdwy	-	-	4.1	-	6.4	6.2
Critical Hdwy Stg 1	-	-	-	-	5.4	-
Critical Hdwy Stg 2	-	-	-	-	5.4	-
Follow-up Hdwy	-	-	2.2	-	3.5	3.3
Pot Cap-1 Maneuver	-	-	1573	-	914	1033
Stage 1	-	-	-	-	985	-
Stage 2	-	-	-	-	980	-
Platoon blocked, %	-	-	-	-	-	-
Mov Cap-1 Maneuver	-	-	1573	-	902	1033
Mov Cap-2 Maneuver	-	-	-	-	902	-
Stage 1	-	-	-	-	985	-
Stage 2	-	-	-	-	967	-

Approach EB WB NB

HCM Control Delay, s 0 5.6 8.9
HCM LOS A

Minor Lane/Major Mvmt NBLn1 EBT EBR WBL WBT

Capacity (veh/h)	994	-	-	1573	-
HCM Lane V/C Ratio	0.078	-	-	0.013	-
HCM Control Delay (s)	8.9	-	-	7.3	0
HCM Lane LOS	A	-	-	A	A
HCM 95th %tile Q(veh)	0.3	-	-	0	-

Intersection

Int Delay, s/veh 1.6

Movement	EBL	EBT	WBT	WBR	SBL	SBR
Lane Configurations		↕	↕		↕	
Traffic Vol, veh/h	0	213	68	20	54	0
Future Vol, veh/h	0	213	68	20	54	0
Conflicting Peds, #/hr	0	0	0	0	0	0
Sign Control	Free	Free	Free	Free	Stop	Stop
RT Channelized	-	None	-	None	-	None
Storage Length	-	-	-	-	0	-
Veh in Median Storage, #	-	0	0	-	0	-
Grade, %	-	0	0	-	0	-
Peak Hour Factor	95	95	95	95	95	95
Heavy Vehicles, %	0	0	0	0	0	0
Mvmt Flow	0	224	72	21	57	0

Major/Minor

	Major1	Major2	Minor2		
Conflicting Flow All	93	0	0	306	82
Stage 1	-	-	-	82	-
Stage 2	-	-	-	224	-
Critical Hdwy	4.1	-	-	6.4	6.2
Critical Hdwy Stg 1	-	-	-	5.4	-
Critical Hdwy Stg 2	-	-	-	5.4	-
Follow-up Hdwy	2.2	-	-	3.5	3.3
Pot Cap-1 Maneuver	1514	-	-	690	983
Stage 1	-	-	-	946	-
Stage 2	-	-	-	818	-
Platoon blocked, %	-	-	-	-	-
Mov Cap-1 Maneuver	1514	-	-	690	983
Mov Cap-2 Maneuver	-	-	-	690	-
Stage 1	-	-	-	946	-
Stage 2	-	-	-	818	-

Approach

	EB	WB	SB
HCM Control Delay, s	0	0	10.7
HCM LOS			B

Minor Lane/Major Mvmt

	EBL	EBT	WBT	WBR	SBLn1
Capacity (veh/h)	1514	-	-	-	690
HCM Lane V/C Ratio	-	-	-	-	0.082
HCM Control Delay (s)	0	-	-	-	10.7
HCM Lane LOS	A	-	-	-	B
HCM 95th %tile Q(veh)	0	-	-	-	0.3

HCM 2010 Signalized Intersection Summary
6: Sierra Ave & Lytle Creek Rd (W/ Realignment)

Existing W/ Project PM
03/16/2018



Movement	EBL	EBR	NBL	NBT	SBT	SBR		
Lane Configurations								
Traffic Volume (veh/h)	6	226	82	630	424	5		
Future Volume (veh/h)	6	226	82	630	424	5		
Number	3	18	1	6	2	12		
Initial Q (Qb), veh	0	0	0	0	0	0		
Ped-Bike Adj(A_pbT)	1.00	1.00	1.00			1.00		
Parking Bus, Adj	1.00	1.00	1.00	1.00	1.00	1.00		
Adj Sat Flow, veh/h/ln	1900	1900	1900	1900	1900	1900		
Adj Flow Rate, veh/h	6	238	86	663	446	5		
Adj No. of Lanes	0	0	1	2	2	0		
Peak Hour Factor	0.95	0.95	0.95	0.95	0.95	0.95		
Percent Heavy Veh, %	0	0	0	0	0	0		
Cap, veh/h	8	306	139	1823	1106	12		
Arrive On Green	0.19	0.19	0.08	0.50	0.30	0.30		
Sat Flow, veh/h	40	1574	1810	3705	3752	41		
Grp Volume(v), veh/h	245	0	86	663	220	231		
Grp Sat Flow(s),veh/h/ln	1620	0	1810	1805	1805	1893		
Q Serve(g_s), s	5.7	0.0	1.8	4.4	3.9	3.9		
Cycle Q Clear(g_c), s	5.7	0.0	1.8	4.4	3.9	3.9		
Prop In Lane	0.02	0.97	1.00			0.02		
Lane Grp Cap(c), veh/h	315	0	139	1823	546	573		
V/C Ratio(X)	0.78	0.00	0.62	0.36	0.40	0.40		
Avail Cap(c_a), veh/h	731	0	408	3078	905	949		
HCM Platoon Ratio	1.00	1.00	1.00	1.00	1.00	1.00		
Upstream Filter(I)	1.00	0.00	1.00	1.00	1.00	1.00		
Uniform Delay (d), s/veh	15.3	0.0	17.8	6.0	11.0	11.0		
Incr Delay (d2), s/veh	4.2	0.0	4.4	0.1	0.5	0.5		
Initial Q Delay(d3),s/veh	0.0	0.0	0.0	0.0	0.0	0.0		
%ile BackOfQ(50%),veh/ln	2.9	0.0	1.1	2.2	2.0	2.1		
LnGrp Delay(d),s/veh	19.4	0.0	22.2	6.1	11.5	11.5		
LnGrp LOS	B		C	A	B	B		
Approach Vol, veh/h	245			749	451			
Approach Delay, s/veh	19.4			8.0	11.5			
Approach LOS	B			A	B			
Timer	1	2	3	4	5	6	7	8
Assigned Phs	1	2				6		8
Phs Duration (G+Y+Rc), s	8.1	18.1				26.1		13.7
Change Period (Y+Rc), s	5.0	6.0				6.0		6.0
Max Green Setting (Gmax), s	9.0	20.0				34.0		18.0
Max Q Clear Time (g_c+I1), s	3.8	5.9				6.4		7.7
Green Ext Time (p_c), s	0.1	6.2				8.3		0.6
Intersection Summary								
HCM 2010 Ctrl Delay			11.0					
HCM 2010 LOS			B					
Notes								

HCM 2010 Signalized Intersection Summary
 7: Sierra Ave & I-15 SB Ramps

Existing W/ Project PM
 03/16/2018



Movement	EBL	EBT	EBR	WBL	WBT	WBR	NBL	NBT	NBR	SBL	SBT	SBR
Lane Configurations				↖	↖	↖	↖	↖			↖	↖
Traffic Volume (veh/h)	0	0	0	282	4	122	163	856	0	0	493	409
Future Volume (veh/h)	0	0	0	282	4	122	163	856	0	0	493	409
Number				7	4	14	1	6	16	5	2	12
Initial Q (Qb), veh				0	0	0	0	0	0	0	0	0
Ped-Bike Adj(A_pbT)				1.00		1.00	1.00		1.00	1.00		1.00
Parking Bus, Adj				1.00	1.00	1.00	1.00	1.00	1.00	1.00	1.00	1.00
Adj Sat Flow, veh/h/ln				1900	1900	1900	1900	1900	0	0	1900	1900
Adj Flow Rate, veh/h				306	0	131	175	920	0	0	530	440
Adj No. of Lanes				2	0	1	1	2	0	0	2	1
Peak Hour Factor				0.93	0.93	0.93	0.93	0.93	0.93	0.93	0.93	0.93
Percent Heavy Veh, %				0	0	0	0	0	0	0	0	0
Cap, veh/h				467	0	209	212	2525	0	0	1845	825
Arrive On Green				0.13	0.00	0.13	0.23	1.00	0.00	0.00	0.51	0.51
Sat Flow, veh/h				3619	0	1615	1810	3705	0	0	3705	1615
Grp Volume(v), veh/h				306	0	131	175	920	0	0	530	440
Grp Sat Flow(s),veh/h/ln				1810	0	1615	1810	1805	0	0	1805	1615
Q Serve(g_s), s				5.6	0.0	5.4	6.4	0.0	0.0	0.0	5.9	12.8
Cycle Q Clear(g_c), s				5.6	0.0	5.4	6.4	0.0	0.0	0.0	5.9	12.8
Prop In Lane				1.00		1.00	1.00		0.00	0.00		1.00
Lane Grp Cap(c), veh/h				467	0	209	212	2525	0	0	1845	825
V/C Ratio(X)				0.65	0.00	0.63	0.83	0.36	0.00	0.00	0.29	0.53
Avail Cap(c_a), veh/h				1293	0	577	259	2525	0	0	1845	825
HCM Platoon Ratio				1.00	1.00	1.00	2.00	2.00	1.00	1.00	1.00	1.00
Upstream Filter(I)				1.00	0.00	1.00	0.84	0.84	0.00	0.00	0.94	0.94
Uniform Delay (d), s/veh				29.0	0.0	28.9	26.1	0.0	0.0	0.0	9.8	11.5
Incr Delay (d2), s/veh				1.6	0.0	3.1	12.0	0.3	0.0	0.0	0.4	2.3
Initial Q Delay(d3),s/veh				0.0	0.0	0.0	0.0	0.0	0.0	0.0	0.0	0.0
%ile BackOfQ(50%),veh/ln				2.9	0.0	2.6	3.9	0.1	0.0	0.0	3.0	6.2
LnGrp Delay(d),s/veh				30.6	0.0	32.0	38.1	0.3	0.0	0.0	10.2	13.8
LnGrp LOS				C		C	D	A			B	B
Approach Vol, veh/h					437			1095			970	
Approach Delay, s/veh					31.0			6.4			11.8	
Approach LOS					C			A			B	
Timer	1	2	3	4	5	6	7	8				
Assigned Phs	1	2		4		6						
Phs Duration (G+Y+Rc), s	3.2	41.8		15.0		55.0						
Change Period (Y+Rc), s	5.0	6.0		6.0		6.0						
Max Green Setting (Gmax), s	18.0			25.0		33.0						
Max Q Clear Time (g_c+I), s	14.8			7.6		2.0						
Green Ext Time (p_c), s	0.0	2.6		1.4		15.5						
Intersection Summary												
HCM 2010 Ctrl Delay				12.8								
HCM 2010 LOS				B								
Notes												

HCM 2010 Signalized Intersection Summary
 8: Sierra Ave & I-15 NB Ramps

Existing W/ Project PM
 03/16/2018



Movement	EBL	EBT	EBR	WBL	WBT	WBR	NBL	NBT	NBR	SBL	SBT	SBR
Lane Configurations												
Traffic Volume (veh/h)	586	0	353	0	0	0	0	433	537	232	543	0
Future Volume (veh/h)	586	0	353	0	0	0	0	433	537	232	543	0
Number	3	8	18				1	6	16	5	2	12
Initial Q (Qb), veh	0	0	0				0	0	0	0	0	0
Ped-Bike Adj(A_pbT)	1.00		1.00				1.00		1.00	1.00		1.00
Parking Bus, Adj	1.00	1.00	1.00				1.00	1.00	1.00	1.00	1.00	1.00
Adj Sat Flow, veh/h/ln	1900	1900	1900				0	1900	1900	1900	1900	0
Adj Flow Rate, veh/h	756	0	256				0	471	584	252	590	0
Adj No. of Lanes	2	0	1				0	2	1	1	2	0
Peak Hour Factor	0.92	0.92	0.92				0.92	0.92	0.92	0.92	0.92	0.92
Percent Heavy Veh, %	0	0	0				0	0	0	0	0	0
Cap, veh/h	465	0	208				0	1753	784	259	2527	0
Arrive On Green	0.13	0.00	0.13				0.00	0.49	0.49	0.19	0.93	0.00
Sat Flow, veh/h	3619	0	1615				0	3705	1615	1810	3705	0
Grp Volume(v), veh/h	756	0	256				0	471	584	252	590	0
Grp Sat Flow(s),veh/h/ln	1810	0	1615				0	1805	1615	1810	1805	0
Q Serve(g_s), s	9.0	0.0	9.0				0.0	5.4	20.4	9.7	1.0	0.0
Cycle Q Clear(g_c), s	9.0	0.0	9.0				0.0	5.4	20.4	9.7	1.0	0.0
Prop In Lane	1.00		1.00				0.00		1.00	1.00		0.00
Lane Grp Cap(c), veh/h	465	0	208				0	1753	784	259	2527	0
V/C Ratio(X)	1.62	0.00	1.23				0.00	0.27	0.74	0.97	0.23	0.00
Avail Cap(c_a), veh/h	465	0	208				0	1753	784	259	2527	0
HCM Platoon Ratio	1.00	1.00	1.00				1.00	1.00	1.00	1.33	1.33	1.00
Upstream Filter(I)	1.00	0.00	1.00				0.00	1.00	1.00	0.93	0.93	0.00
Uniform Delay (d), s/veh	30.5	0.0	30.5				0.0	10.6	14.5	28.2	0.8	0.0
Incr Delay (d2), s/veh	290.9	0.0	139.3				0.0	0.4	6.3	46.7	0.2	0.0
Initial Q Delay(d3),s/veh	0.0	0.0	0.0				0.0	0.0	0.0	0.0	0.0	0.0
%ile BackOfQ(50%),veh/ln	23.3	0.0	12.0				0.0	2.8	10.3	8.2	0.5	0.0
LnGrp Delay(d),s/veh	321.4	0.0	169.8				0.0	11.0	20.8	74.9	1.0	0.0
LnGrp LOS	F		F					B	C	E	A	
Approach Vol, veh/h		1012						1055			842	
Approach Delay, s/veh		283.0						16.5			23.1	
Approach LOS		F						B			C	
Timer	1	2	3	4	5	6	7	8				
Assigned Phs		2			5	6		8				
Phs Duration (G+Y+Rc), s		55.0			15.0	40.0		15.0				
Change Period (Y+Rc), s		6.0			5.0	6.0		6.0				
Max Green Setting (Gmax), s		49.0			10.0	34.0		9.0				
Max Q Clear Time (g_c+I1), s		3.0			11.7	22.4		11.0				
Green Ext Time (p_c), s		13.5			0.0	7.0		0.0				
Intersection Summary												
HCM 2010 Ctrl Delay			111.1									
HCM 2010 LOS			F									
Notes												

Intersection

Intersection Delay, s/veh 19.4
Intersection LOS F

Movement	WBL	WBR	NBT	NBR	SBL	SBT
Lane Configurations	↘	↗	↑	↗	↘	↑↑
Traffic Vol, veh/h	20	448	522	19	488	408
Future Vol, veh/h	20	448	522	19	488	408
Peak Hour Factor	0.94	0.94	0.94	0.94	0.94	0.94
Heavy Vehicles, %	0	0	0	0	0	0
Mvmt Flow	21	477	555	20	519	434
Number of Lanes	1	1	1	1	1	2

Approach	WB	NB	SB
Opposing Approach		SB	NB
Opposing Lanes	0	3	2
Conflicting Approach Left NB			WB
Conflicting Lanes Left	2	0	2
Conflicting Approach Right SB		WB	
Conflicting Lanes Right	3	2	0
HCM Control Delay	86.9	188.8	94.5
HCM LOS	F	F	F

Lane	NBLn1	NBLn2	WBLn1	WBLn2	SBLn1	SBLn2	SBLn3
Vol Left, %	0%	0%	100%	0%	100%	0%	0%
Vol Thru, %	100%	0%	0%	0%	0%	100%	100%
Vol Right, %	0%	100%	0%	100%	0%	0%	0%
Sign Control	Stop	Stop	Stop	Stop	Stop	Stop	Stop
Traffic Vol by Lane	522	19	20	448	488	204	204
LT Vol	0	0	20	0	488	0	0
Through Vol	522	0	0	0	0	204	204
RT Vol	0	19	0	448	0	0	0
Lane Flow Rate	555	20	21	477	519	217	217
Geometry Grp	8	8	8	8	8	8	8
Degree of Util (X)	1.339	0.045	0.054	1.055	1.246	0.491	0.389
Departure Headway (Hd)	9.316	8.582	10.17	8.92	9.5	8.977	7.201
Convergence, Y/N	Yes	Yes	Yes	Yes	Yes	Yes	Yes
Cap	394	420	354	410	384	404	503
Service Time	7.016	6.282	7.87	6.62	7.2	6.677	4.901
HCM Lane V/C Ratio	1.409	0.048	0.059	1.163	1.352	0.537	0.431
HCM Control Delay	195.2	11.7	13.4	90.2	159.1	20	14.4
HCM Lane LOS	F	B	B	F	F	C	B
HCM 95th-tile Q	24.3	0.1	0.2	14.1	20.4	2.6	1.8

HCM 2010 Signalized Intersection Summary
 8: Sierra Ave & I-15 NB Ramps











Existing W/ Project PM
 03/19/2018

Movement	EBL	EBT	EBR	WBL	WBT	WBR	NBL	NBT	NBR	SBL	SBT	SBR
Lane Configurations												
Traffic Volume (veh/h)	586	0	353	0	0	0	0	433	537	232	543	0
Future Volume (veh/h)	586	0	353	0	0	0	0	433	537	232	543	0
Number	3	8	18				1	6	16	5	2	12
Initial Q (Qb), veh	0	0	0				0	0	0	0	0	0
Ped-Bike Adj(A_pbT)	1.00		1.00				1.00		1.00	1.00		1.00
Parking Bus, Adj	1.00	1.00	1.00				1.00	1.00	1.00	1.00	1.00	1.00
Adj Sat Flow, veh/h/ln	1900	1900	1900				0	1900	1900	1900	1900	0
Adj Flow Rate, veh/h	756	0	256				0	471	584	252	590	0
Adj No. of Lanes	2	0	1				0	2	1	1	2	0
Peak Hour Factor	0.92	0.92	0.92				0.92	0.92	0.92	0.92	0.92	0.92
Percent Heavy Veh, %	0	0	0				0	0	0	0	0	0
Cap, veh/h	875	0	390				0	1284	574	289	2118	0
Arrive On Green	0.24	0.00	0.24				0.00	0.36	0.36	0.32	1.00	0.00
Sat Flow, veh/h	3619	0	1615				0	3705	1615	1810	3705	0
Grp Volume(v), veh/h	756	0	256				0	471	584	252	590	0
Grp Sat Flow(s),veh/h/ln	1810	0	1615				0	1805	1615	1810	1805	0
Q Serve(g_s), s	14.0	0.0	10.0				0.0	6.8	24.9	9.2	0.0	0.0
Cycle Q Clear(g_c), s	14.0	0.0	10.0				0.0	6.8	24.9	9.2	0.0	0.0
Prop In Lane	1.00		1.00				0.00		1.00	1.00		0.00
Lane Grp Cap(c), veh/h	875	0	390				0	1284	574	289	2118	0
V/C Ratio(X)	0.86	0.00	0.66				0.00	0.37	1.02	0.87	0.28	0.00
Avail Cap(c_a), veh/h	931	0	415				0	1284	574	336	2118	0
HCM Platoon Ratio	1.00	1.00	1.00				1.00	1.00	1.00	2.00	2.00	1.00
Upstream Filter(I)	1.00	0.00	1.00				0.00	1.00	1.00	0.93	0.93	0.00
Uniform Delay (d), s/veh	25.4	0.0	23.9				0.0	16.7	22.6	23.1	0.0	0.0
Incr Delay (d2), s/veh	8.1	0.0	3.4				0.0	0.8	41.9	16.5	0.3	0.0
Initial Q Delay(d3),s/veh	0.0	0.0	0.0				0.0	0.0	0.0	0.0	0.0	0.0
%ile BackOfQ(50%),veh/ln	7.9	0.0	4.8				0.0	3.5	17.7	5.8	0.1	0.0
LnGrp Delay(d),s/veh	33.6	0.0	27.3				0.0	17.5	64.5	39.6	0.3	0.0
LnGrp LOS	C		C					B	F	D	A	
Approach Vol, veh/h		1012						1055			842	
Approach Delay, s/veh		32.0						43.5			12.1	
Approach LOS		C						D			B	
Timer	1	2	3	4	5	6	7	8				
Assigned Phs		2			5	6		8				
Phs Duration (G+Y+Rc), s		47.1			16.2	30.9		22.9				
Change Period (Y+Rc), s		6.0			5.0	6.0		6.0				
Max Green Setting (Gmax), s		40.0			13.0	22.0		18.0				
Max Q Clear Time (g_c+I1), s		2.0			11.2	26.9		16.0				
Green Ext Time (p_c), s		12.9			0.1	0.0		0.9				
Intersection Summary												
HCM 2010 Ctrl Delay			30.4									
HCM 2010 LOS			C									
Notes												
User approved volume balancing among the lanes for turning movement.												

HCM Signalized Intersection Capacity Analysis

9: Sierra Ave & Riverside Ave











Existing W/ Project AM
With Mitigation 03/19/2018

						
Movement	WBL	WBR	NBT	NBR	SBL	SBT
Lane Configurations						
Traffic Volume (vph)	41	497	314	36	404	527
Future Volume (vph)	41	497	314	36	404	527
Ideal Flow (vphpl)	1900	1900	1900	1900	1900	1900
Total Lost time (s)	6.0	6.0	6.0		5.0	6.0
Lane Util. Factor	1.00	1.00	0.95		1.00	0.95
Frt	1.00	0.85	0.98		1.00	1.00
Flt Protected	0.95	1.00	1.00		0.95	1.00
Satd. Flow (prot)	1805	1615	3554		1805	3610
Flt Permitted	0.95	1.00	1.00		0.95	1.00
Satd. Flow (perm)	1805	1615	3554		1805	3610
Peak-hour factor, PHF	0.92	0.92	0.92	0.92	0.92	0.92
Adj. Flow (vph)	45	540	341	39	439	573
RTOR Reduction (vph)	0	438	8	0	0	0
Lane Group Flow (vph)	45	102	372	0	439	573
Heavy Vehicles (%)	0%	0%	0%	0%	0%	0%
Turn Type	Perm	Perm	NA		Prot	NA
Protected Phases			6		5	2
Permitted Phases	4	4				
Actuated Green, G (s)	12.1	12.1	13.6		21.4	40.0
Effective Green, g (s)	12.1	12.1	13.6		21.4	40.0
Actuated g/C Ratio	0.19	0.19	0.21		0.33	0.62
Clearance Time (s)	6.0	6.0	6.0		5.0	6.0
Vehicle Extension (s)	3.0	3.0	3.0		3.0	3.0
Lane Grp Cap (vph)	340	304	754		602	2252
v/s Ratio Prot			c0.10		c0.24	0.16
v/s Ratio Perm	0.02	c0.06				
v/c Ratio	0.13	0.34	0.49		0.73	0.25
Uniform Delay, d1	21.6	22.5	22.2		18.8	5.4
Progression Factor	1.00	1.00	1.00		1.00	1.00
Incremental Delay, d2	0.2	0.7	0.5		4.4	0.1
Delay (s)	21.8	23.2	22.7		23.2	5.4
Level of Service	C	C	C		C	A
Approach Delay (s)	23.1		22.7			13.2
Approach LOS	C		C			B
Intersection Summary						
HCM 2000 Control Delay			17.9		HCM 2000 Level of Service	B
HCM 2000 Volume to Capacity ratio			0.56			
Actuated Cycle Length (s)			64.1		Sum of lost time (s)	17.0
Intersection Capacity Utilization			54.7%		ICU Level of Service	A
Analysis Period (min)			15			
c Critical Lane Group						

HCM Signalized Intersection Capacity Analysis

9: Sierra Ave & Riverside Ave

Existing W/ Project PM
With Mitigation 03/19/2018























						
Movement	WBL	WBR	NBT	NBR	SBL	SBT
Lane Configurations						
Traffic Volume (vph)	20	448	522	19	488	408
Future Volume (vph)	20	448	522	19	488	408
Ideal Flow (vphpl)	1900	1900	1900	1900	1900	1900
Total Lost time (s)	6.0	6.0	6.0		5.0	6.0
Lane Util. Factor	1.00	1.00	0.95		1.00	0.95
Frt	1.00	0.85	0.99		1.00	1.00
Flt Protected	0.95	1.00	1.00		0.95	1.00
Satd. Flow (prot)	1805	1615	3591		1805	3610
Flt Permitted	0.95	1.00	1.00		0.95	1.00
Satd. Flow (perm)	1805	1615	3591		1805	3610
Peak-hour factor, PHF	0.94	0.94	0.94	0.94	0.94	0.94
Adj. Flow (vph)	21	477	555	20	519	434
RTOR Reduction (vph)	0	401	2	0	0	0
Lane Group Flow (vph)	21	76	573	0	519	434
Heavy Vehicles (%)	0%	0%	0%	0%	0%	0%
Turn Type	Perm	Perm	NA		Prot	NA
Protected Phases			6		5	2
Permitted Phases	4	4				
Actuated Green, G (s)	12.0	12.0	19.1		27.5	51.6
Effective Green, g (s)	12.0	12.0	19.1		27.5	51.6
Actuated g/C Ratio	0.16	0.16	0.25		0.36	0.68
Clearance Time (s)	6.0	6.0	6.0		5.0	6.0
Vehicle Extension (s)	3.0	3.0	3.0		3.0	3.0
Lane Grp Cap (vph)	286	256	907		656	2463
v/s Ratio Prot			c0.16		c0.29	0.12
v/s Ratio Perm	0.01	c0.05				
v/c Ratio	0.07	0.30	0.63		0.79	0.18
Uniform Delay, d1	27.1	28.1	25.1		21.5	4.3
Progression Factor	1.00	1.00	1.00		1.00	1.00
Incremental Delay, d2	0.1	0.6	1.4		6.5	0.0
Delay (s)	27.2	28.7	26.6		28.0	4.4
Level of Service	C	C	C		C	A
Approach Delay (s)	28.7		26.6			17.2
Approach LOS	C		C			B
Intersection Summary						
HCM 2000 Control Delay			22.7		HCM 2000 Level of Service	C
HCM 2000 Volume to Capacity ratio			0.64			
Actuated Cycle Length (s)			75.6		Sum of lost time (s)	17.0
Intersection Capacity Utilization			64.6%		ICU Level of Service	C
Analysis Period (min)			15			
c Critical Lane Group						

**Appendix E:
Opening Year 2020
Without Project
Synchro Worksheets**

This page intentionally left blank

HCM 2010 Signalized Intersection Summary
 1: Cayote Canyon Rd & Duncan Canyon Rd

Opening Year 2020 AM
 02/25/2019

												
Movement	EBL	EBT	EBR	WBL	WBT	WBR	NBL	NBT	NBR	SBL	SBT	SBR
Lane Configurations												
Traffic Volume (veh/h)	6	318	9	28	130	152	5	3	92	436	4	10
Future Volume (veh/h)	6	318	9	28	130	152	5	3	92	436	4	10
Number	5	2	12	1	6	16	3	8	18	7	4	14
Initial Q (Qb), veh	0	0	0	0	0	0	0	0	0	0	0	0
Ped-Bike Adj(A_pbT)	1.00		1.00	1.00		1.00	1.00		1.00	1.00		1.00
Parking Bus, Adj	1.00	1.00	1.00	1.00	1.00	1.00	1.00	1.00	1.00	1.00	1.00	1.00
Adj Sat Flow, veh/h/ln	1900	1900	1900	1900	1900	1900	1900	1900	1900	1900	1900	1900
Adj Flow Rate, veh/h	6	338	10	30	138	162	5	3	98	464	4	11
Adj No. of Lanes	1	2	0	1	2	0	1	1	1	1	1	1
Peak Hour Factor	0.94	0.94	0.94	0.94	0.94	0.94	0.94	0.94	0.94	0.94	0.94	0.94
Percent Heavy Veh, %	0	0	0	0	0	0	0	0	0	0	0	0
Cap, veh/h	15	596	18	63	349	312	0	156	189	563	591	502
Arrive On Green	0.01	0.17	0.17	0.03	0.19	0.19	0.08	0.08	0.08	0.31	0.31	0.31
Sat Flow, veh/h	1810	3581	106	1810	1805	1615	0	1900	1615	1810	1900	1615
Grp Volume(v), veh/h	6	170	178	30	138	162	0	3	98	464	4	11
Grp Sat Flow(s),veh/h/ln	1810	1805	1881	1810	1805	1615	0	1900	1615	1810	1900	1615
Q Serve(g_s), s	0.1	3.8	3.9	0.7	3.0	4.0	0.0	0.1	2.5	10.5	0.1	0.2
Cycle Q Clear(g_c), s	0.1	3.8	3.9	0.7	3.0	4.0	0.0	0.1	2.5	10.5	0.1	0.2
Prop In Lane	1.00		0.06	1.00		1.00	0.00		1.00	1.00		1.00
Lane Grp Cap(c), veh/h	15	301	313	63	349	312	0	156	189	563	591	502
V/C Ratio(X)	0.41	0.57	0.57	0.48	0.40	0.52	0.00	0.02	0.52	0.82	0.01	0.02
Avail Cap(c_a), veh/h	224	427	445	224	427	382	0	235	256	1039	1091	927
HCM Platoon Ratio	1.00	1.00	1.00	1.00	1.00	1.00	1.00	1.00	1.00	1.00	1.00	1.00
Upstream Filter(I)	1.00	1.00	1.00	1.00	1.00	1.00	0.00	1.00	1.00	1.00	1.00	1.00
Uniform Delay (d), s/veh	21.9	17.0	17.0	21.0	15.6	16.1	0.0	18.7	18.4	14.2	10.6	10.6
Incr Delay (d2), s/veh	17.6	1.7	1.6	5.5	0.7	1.3	0.0	0.0	2.2	3.1	0.0	0.0
Initial Q Delay(d3),s/veh	0.0	0.0	0.0	0.0	0.0	0.0	0.0	0.0	0.0	0.0	0.0	0.0
%ile BackOfQ(50%),veh/ln	0.1	2.0	2.1	0.5	1.5	1.9	0.0	0.0	1.2	5.6	0.0	0.1
LnGrp Delay(d),s/veh	39.6	18.7	18.7	26.5	16.4	17.4	0.0	18.8	20.6	17.3	10.6	10.6
LnGrp LOS	D	B	B	C	B	B		B	C	B	B	B
Approach Vol, veh/h		354			330			101			479	
Approach Delay, s/veh		19.0			17.8			20.6			17.1	
Approach LOS		B			B			C			B	
Timer	1	2	3	4	5	6	7	8				
Assigned Phs	1	2		4	5	6		8				
Phs Duration (G+Y+Rc), s	6.0	11.9		18.3	4.9	13.1		8.1				
Change Period (Y+Rc), s	4.5	4.5		4.5	4.5	4.5		* 4.5				
Max Green Setting (Gmax), s	5.5	10.5		25.5	5.5	10.5		* 5.5				
Max Q Clear Time (g_c+1), s	2.7	5.9		12.5	2.1	6.0		4.5				
Green Ext Time (p_c), s	0.0	1.5		1.3	0.0	1.5		0.0				
Intersection Summary												
HCM 2010 Ctrl Delay			18.1									
HCM 2010 LOS			B									
Notes												

Intersection

Int Delay, s/veh 3

Movement EBL EBR NBL NBT SBT SBR

Lane Configurations	↘↗		↘	↑↑	↑↑	
Traffic Vol, veh/h	4	166	76	354	1035	14
Future Vol, veh/h	4	166	76	354	1035	14
Conflicting Peds, #/hr	0	0	0	0	0	0
Sign Control	Stop	Stop	Free	Free	Free	Free
RT Channelized	-	None	-	None	-	None
Storage Length	0	-	120	-	-	-
Veh in Median Storage, #	0	-	-	0	0	-
Grade, %	0	-	-	0	0	-
Peak Hour Factor	84	84	84	84	84	84
Heavy Vehicles, %	0	0	0	0	0	0
Mvmt Flow	5	198	90	421	1232	17

Major/Minor Minor2 Major1 Major2

Conflicting Flow All	1632	624	1249	0	-	0
Stage 1	1240	-	-	-	-	-
Stage 2	392	-	-	-	-	-
Critical Hdwy	6.8	6.9	4.1	-	-	-
Critical Hdwy Stg 1	5.8	-	-	-	-	-
Critical Hdwy Stg 2	5.8	-	-	-	-	-
Follow-up Hdwy	3.5	3.3	2.2	-	-	-
Pot Cap-1 Maneuver	94	433	564	-	-	-
Stage 1	240	-	-	-	-	-
Stage 2	658	-	-	-	-	-
Platoon blocked, %				-	-	-
Mov Cap-1 Maneuver	79	433	564	-	-	-
Mov Cap-2 Maneuver	79	-	-	-	-	-
Stage 1	240	-	-	-	-	-
Stage 2	553	-	-	-	-	-

Approach EB NB SB



















HCM Control Delay, s	23.6	2.2	0
HCM LOS	C		

Minor Lane/Major Mvmt NBL NBT EBLn1 SBT SBR

Capacity (veh/h)	564	-	392	-	-
HCM Lane V/C Ratio	0.16	-	0.516	-	-
HCM Control Delay (s)	12.6	-	23.6	-	-
HCM Lane LOS	B	-	C	-	-
HCM 95th %tile Q(veh)	0.6	-	2.9	-	-

HCM 2010 Signalized Intersection Summary
 7: Sierra Ave & I-15 SB Ramps

Opening Year 2020 AM
 03/16/2018

												
Movement	EBL	EBT	EBR	WBL	WBT	WBR	NBL	NBT	NBR	SBL	SBT	SBR
Lane Configurations												
Traffic Volume (veh/h)	0	0	0	702	0	185	543	483	0	0	463	926
Future Volume (veh/h)	0	0	0	702	0	185	543	483	0	0	463	926
Number				7	4	14	1	6	16	5	2	12
Initial Q (Qb), veh				0	0	0	0	0	0	0	0	0
Ped-Bike Adj(A_pbT)				1.00		1.00	1.00		1.00	1.00		1.00
Parking Bus, Adj				1.00	1.00	1.00	1.00	1.00	1.00	1.00	1.00	1.00
Adj Sat Flow, veh/h/ln				1900	1900	1900	1900	1900	0	0	1900	1900
Adj Flow Rate, veh/h				789	0	208	610	543	0	0	520	1040
Adj No. of Lanes				2	0	1	1	2	0	0	2	1
Peak Hour Factor				0.89	0.89	0.89	0.89	0.89	0.89	0.89	0.89	0.89
Percent Heavy Veh, %				0	0	0	0	0	0	0	0	0
Cap, veh/h				696	0	311	515	2583	0	0	1416	634
Arrive On Green				0.19	0.00	0.19	0.48	1.00	0.00	0.00	0.39	0.39
Sat Flow, veh/h				3619	0	1615	1810	3705	0	0	3705	1615
Grp Volume(v), veh/h				789	0	208	610	543	0	0	520	1040
Grp Sat Flow(s),veh/h/ln				1810	0	1615	1810	1805	0	0	1805	1615
Q Serve(g_s), s				25.0	0.0	15.5	37.0	0.0	0.0	0.0	13.3	51.0
Cycle Q Clear(g_c), s				25.0	0.0	15.5	37.0	0.0	0.0	0.0	13.3	51.0
Prop In Lane				1.00		1.00	1.00		0.00	0.00		1.00
Lane Grp Cap(c), veh/h				696	0	311	515	2583	0	0	1416	634
V/C Ratio(X)				1.13	0.00	0.67	1.18	0.21	0.00	0.00	0.37	1.64
Avail Cap(c_a), veh/h				696	0	311	515	2583	0	0	1416	634
HCM Platoon Ratio				1.00	1.00	1.00	1.67	1.67	1.00	1.00	1.00	1.00
Upstream Filter(I)				1.00	0.00	1.00	0.89	0.89	0.00	0.00	1.00	1.00
Uniform Delay (d), s/veh				52.5	0.0	48.7	34.1	0.0	0.0	0.0	28.0	39.5
Incr Delay (d2), s/veh				77.2	0.0	5.5	99.6	0.2	0.0	0.0	0.7	295.8
Initial Q Delay(d3),s/veh				0.0	0.0	0.0	0.0	0.0	0.0	0.0	0.0	0.0
%ile BackOfQ(50%),veh/ln				19.9	0.0	7.4	32.6	0.1	0.0	0.0	6.8	74.8
LnGrp Delay(d),s/veh				129.7	0.0	54.1	133.7	0.2	0.0	0.0	28.8	335.3
LnGrp LOS				F		D	F	A			C	F
Approach Vol, veh/h					997			1153			1560	
Approach Delay, s/veh					114.0			70.8			233.1	
Approach LOS					F			E			F	
Timer	1	2	3	4	5	6	7	8				
Assigned Phs	1	2		4		6						
Phs Duration (G+Y+Rc), s	42.0	57.0		31.0		99.0						
Change Period (Y+Rc), s	5.0	6.0		6.0		6.0						
Max Green Setting (Gmax), s	37.0	51.0		25.0		93.0						
Max Q Clear Time (g_c+I1), s	39.0	53.0		27.0		2.0						
Green Ext Time (p_c), s	0.0	0.0		0.0		23.6						
Intersection Summary												
HCM 2010 Ctrl Delay				150.6								
HCM 2010 LOS				F								
Notes												

HCM 2010 Signalized Intersection Summary
 8: Sierra Ave & I-15 NB Ramps

Opening Year 2020 AM
 03/16/2018



Movement	EBL	EBT	EBR	WBL	WBT	WBR	NBL	NBT	NBR	SBL	SBT	SBR
Lane Configurations												
Traffic Volume (veh/h)	279	0	238	0	0	0	0	747	673	143	1022	0
Future Volume (veh/h)	279	0	238	0	0	0	0	747	673	143	1022	0
Number	3	8	18				1	6	16	5	2	12
Initial Q (Qb), veh	0	0	0				0	0	0	0	0	0
Ped-Bike Adj(A_pbT)	1.00		1.00				1.00		1.00	1.00		1.00
Parking Bus, Adj	1.00	1.00	1.00				1.00	1.00	1.00	1.00	1.00	1.00
Adj Sat Flow, veh/h/ln	1900	1900	1900				0	1900	1900	1900	1900	0
Adj Flow Rate, veh/h	396	0	178				0	839	756	161	1148	0
Adj No. of Lanes	2	0	1				0	2	1	1	2	0
Peak Hour Factor	0.89	0.89	0.89				0.89	0.89	0.89	0.89	0.89	0.89
Percent Heavy Veh, %	0	0	0				0	0	0	0	0	0
Cap, veh/h	489	0	218				0	2281	1020	185	2789	0
Arrive On Green	0.14	0.00	0.14				0.00	0.63	0.63	0.20	1.00	0.00
Sat Flow, veh/h	3619	0	1615				0	3705	1615	1810	3705	0
Grp Volume(v), veh/h	396	0	178				0	839	756	161	1148	0
Grp Sat Flow(s),veh/h/ln	1810	0	1615				0	1805	1615	1810	1805	0
Q Serve(g_s), s	13.8	0.0	13.9				0.0	14.5	42.1	11.2	0.0	0.0
Cycle Q Clear(g_c), s	13.8	0.0	13.9				0.0	14.5	42.1	11.2	0.0	0.0
Prop In Lane	1.00		1.00				0.00		1.00	1.00		0.00
Lane Grp Cap(c), veh/h	489	0	218				0	2281	1020	185	2789	0
V/C Ratio(X)	0.81	0.00	0.82				0.00	0.37	0.74	0.87	0.41	0.00
Avail Cap(c_a), veh/h	752	0	335				0	2281	1020	306	2789	0
HCM Platoon Ratio	1.00	1.00	1.00				1.00	1.00	1.00	2.00	2.00	1.00
Upstream Filter(l)	1.00	0.00	1.00				0.00	0.30	0.30	0.64	0.64	0.00
Uniform Delay (d), s/veh	54.6	0.0	54.6				0.0	11.5	16.6	50.9	0.0	0.0
Incr Delay (d2), s/veh	3.9	0.0	8.7				0.0	0.1	1.5	4.9	0.3	0.0
Initial Q Delay(d3),s/veh	0.0	0.0	0.0				0.0	0.0	0.0	0.0	0.0	0.0
%ile BackOfQ(50%),veh/ln	7.2	0.0	6.8				0.0	7.3	19.1	5.8	0.1	0.0
LnGrp Delay(d),s/veh	58.5	0.0	63.4				0.0	11.6	18.0	55.8	0.3	0.0
LnGrp LOS	E		E					B	B	E	A	
Approach Vol, veh/h		574						1595			1309	
Approach Delay, s/veh		60.0						14.7			7.1	
Approach LOS		E						B			A	
Timer	1	2	3	4	5	6	7	8				
Assigned Phs		2			5	6		8				
Phs Duration (G+Y+Rc), s		106.4			18.3	88.1		23.6				
Change Period (Y+Rc), s		6.0			5.0	6.0		6.0				
Max Green Setting (Gmax), s		91.0			22.0	64.0		27.0				
Max Q Clear Time (g_c+1l), s		2.0			13.2	44.1		15.9				
Green Ext Time (p_c), s		44.2			0.1	16.3		1.6				
Intersection Summary												
HCM 2010 Ctrl Delay			19.3									
HCM 2010 LOS			B									
Notes												

HCM Signalized Intersection Capacity Analysis
 9: Sierra Ave & Riverside Ave

Opening Year 2020 AM
 03/16/2018

























Movement	WBL	WBR	NBT	NBR	SBL	SBT
Lane Configurations						
Traffic Volume (vph)	43	627	793	37	562	698
Future Volume (vph)	43	627	793	37	562	698
Ideal Flow (vphpl)	1900	1900	1900	1900	1900	1900
Total Lost time (s)	8.0	8.0	8.0		7.0	8.0
Lane Util. Factor	1.00	1.00	0.95		1.00	0.95
Frt	1.00	0.85	0.99		1.00	1.00
Flt Protected	0.95	1.00	1.00		0.95	1.00
Satd. Flow (prot)	1805	1615	3586		1805	3610
Flt Permitted	0.95	1.00	1.00		0.95	1.00
Satd. Flow (perm)	1805	1615	3586		1805	3610
Peak-hour factor, PHF	0.92	0.92	0.92	0.92	0.92	0.92
Adj. Flow (vph)	47	682	862	40	611	759
RTOR Reduction (vph)	0	535	3	0	0	0
Lane Group Flow (vph)	47	147	899	0	611	759
Heavy Vehicles (%)	0%	0%	0%	0%	0%	0%
Turn Type	Perm	Perm	NA		Prot	NA
Protected Phases			6		5	2
Permitted Phases	4	4				
Actuated Green, G (s)	15.2	15.2	30.4		39.0	74.4
Effective Green, g (s)	13.2	13.2	28.4		37.0	72.4
Actuated g/C Ratio	0.13	0.13	0.28		0.36	0.71
Clearance Time (s)	6.0	6.0	6.0		5.0	6.0
Vehicle Extension (s)	3.0	3.0	3.0		3.0	3.0
Lane Grp Cap (vph)	234	209	1002		657	2572
v/s Ratio Prot			c0.25		c0.34	0.21
v/s Ratio Perm	0.03	c0.09				
v/c Ratio	0.20	0.70	0.90		0.93	0.30
Uniform Delay, d1	39.5	42.3	35.2		31.1	5.3
Progression Factor	1.00	1.00	1.00		1.00	1.00
Incremental Delay, d2	0.4	10.2	10.5		19.6	0.1
Delay (s)	39.9	52.5	45.7		50.6	5.4
Level of Service	D	D	D		D	A
Approach Delay (s)	51.7		45.7			25.6
Approach LOS	D		D			C

Intersection Summary			
HCM 2000 Control Delay		38.0	HCM 2000 Level of Service D
HCM 2000 Volume to Capacity ratio		0.86	
Actuated Cycle Length (s)		101.6	Sum of lost time (s) 21.0
Intersection Capacity Utilization		81.7%	ICU Level of Service D
Analysis Period (min)		15	
c Critical Lane Group			

HCM 2010 Signalized Intersection Summary
 1: Cayote Canyon Rd & Duncan Canyon Rd

Opening Year 2020 PM
 02/25/2019

												
Movement	EBL	EBT	EBR	WBL	WBT	WBR	NBL	NBT	NBR	SBL	SBT	SBR
Lane Configurations												
Traffic Volume (veh/h)	15	201	10	122	280	471	9	1	75	299	0	4
Future Volume (veh/h)	15	201	10	122	280	471	9	1	75	299	0	4
Number	5	2	12	1	6	16	3	8	18	7	4	14
Initial Q (Qb), veh	0	0	0	0	0	0	0	0	0	0	0	0
Ped-Bike Adj(A_pbT)	1.00		1.00	1.00		1.00	1.00		1.00	1.00		1.00
Parking Bus, Adj	1.00	1.00	1.00	1.00	1.00	1.00	1.00	1.00	1.00	1.00	1.00	1.00
Adj Sat Flow, veh/h/ln	1900	1900	1900	1900	1900	1900	1900	1900	1900	1900	1900	1900
Adj Flow Rate, veh/h	17	231	11	140	322	541	10	1	86	344	0	5
Adj No. of Lanes	1	2	0	1	2	0	1	1	1	1	1	1
Peak Hour Factor	0.87	0.87	0.87	0.87	0.87	0.87	0.87	0.87	0.87	0.87	0.87	0.87
Percent Heavy Veh, %	0	0	0	0	0	0	0	0	0	0	0	0
Cap, veh/h	72	1002	47	226	669	599	0	250	415	399	419	356
Arrive On Green	0.04	0.29	0.29	0.12	0.37	0.37	0.13	0.13	0.13	0.22	0.00	0.22
Sat Flow, veh/h	1810	3509	166	1810	1805	1615	0	1900	1615	1810	1900	1615
Grp Volume(v), veh/h	17	118	124	140	322	541	0	1	86	344	0	5
Grp Sat Flow(s),veh/h/ln	1810	1805	1871	1810	1805	1615	0	1900	1615	1810	1900	1615
Q Serve(g_s), s	0.7	3.8	3.8	5.6	10.4	24.1	0.0	0.0	3.2	13.9	0.0	0.2
Cycle Q Clear(g_c), s	0.7	3.8	3.8	5.6	10.4	24.1	0.0	0.0	3.2	13.9	0.0	0.2
Prop In Lane	1.00		0.09	1.00		1.00	0.00		1.00	1.00		1.00
Lane Grp Cap(c), veh/h	72	515	534	226	669	599	0	250	415	399	419	356
V/C Ratio(X)	0.24	0.23	0.23	0.62	0.48	0.90	0.00	0.00	0.21	0.86	0.00	0.01
Avail Cap(c_a), veh/h	238	619	641	322	702	628	0	576	691	704	739	628
HCM Platoon Ratio	1.00	1.00	1.00	1.00	1.00	1.00	1.00	1.00	1.00	1.00	1.00	1.00
Upstream Filter(I)	1.00	1.00	1.00	1.00	1.00	1.00	0.00	1.00	1.00	1.00	0.00	1.00
Uniform Delay (d), s/veh	35.3	20.7	20.7	31.5	18.3	22.6	0.0	28.6	22.1	28.4	0.0	23.1
Incr Delay (d2), s/veh	1.7	0.2	0.2	2.8	0.5	16.1	0.0	0.0	0.2	5.6	0.0	0.0
Initial Q Delay(d3),s/veh	0.0	0.0	0.0	0.0	0.0	0.0	0.0	0.0	0.0	0.0	0.0	0.0
%ile BackOfQ(50%),veh/ln	0.4	1.9	2.0	2.9	5.2	13.4	0.0	0.0	1.4	7.5	0.0	0.1
LnGrp Delay(d),s/veh	37.0	21.0	21.0	34.2	18.8	38.7	0.0	28.6	22.4	34.0	0.0	23.1
LnGrp LOS	D	C	C	C	B	D		C	C	C		C
Approach Vol, veh/h		259			1003			87			349	
Approach Delay, s/veh		22.0			31.7			22.5			33.9	
Approach LOS		C			C			C			C	
Timer	1	2	3	4	5	6	7	8				
Assigned Phs	1	2		4	5	6		8				
Phs Duration (G+Y+Rc), s	14.0	26.2		21.2	7.5	32.6		14.5				
Change Period (Y+Rc), s	4.5	4.5		4.5	4.5	4.5		* 4.5				
Max Green Setting (Gmax), s	13.5	26.0		29.5	10.0	29.5		* 23				
Max Q Clear Time (g_c+I1), s	7.6	5.8		15.9	2.7	26.1		5.2				
Green Ext Time (p_c), s	0.2	7.0		0.9	0.0	2.1		0.2				
Intersection Summary												
HCM 2010 Ctrl Delay				30.2								
HCM 2010 LOS				C								
Notes												

Intersection						
Int Delay, s/veh	2.7					
Movement	EBL	EBR	NBL	NBT	SBT	SBR
Lane Configurations	W		W	↑↑	↑↑	
Traffic Vol, veh/h	15	140	203	752	502	3
Future Vol, veh/h	15	140	203	752	502	3
Conflicting Peds, #/hr	0	0	0	0	0	0
Sign Control	Stop	Stop	Free	Free	Free	Free
RT Channelized	-	None	-	None	-	None
Storage Length	0	-	120	-	-	-
Veh in Median Storage, #	0	-	-	0	0	-
Grade, %	0	-	-	0	0	-
Peak Hour Factor	95	95	95	95	95	95
Heavy Vehicles, %	0	0	0	0	0	0
Mvmt Flow	16	147	214	792	528	3



















Major/Minor	Minor2	Major1	Major2			
Conflicting Flow All	1353	266	532	0	-	0
Stage 1	530	-	-	-	-	-
Stage 2	823	-	-	-	-	-
Critical Hdwy	6.8	6.9	4.1	-	-	-
Critical Hdwy Stg 1	5.8	-	-	-	-	-
Critical Hdwy Stg 2	5.8	-	-	-	-	-
Follow-up Hdwy	3.5	3.3	2.2	-	-	-
Pot Cap-1 Maneuver	144	738	1046	-	-	-
Stage 1	560	-	-	-	-	-
Stage 2	397	-	-	-	-	-
Platoon blocked, %				-	-	-
Mov Cap-1 Maneuver	115	738	1046	-	-	-
Mov Cap-2 Maneuver	115	-	-	-	-	-
Stage 1	560	-	-	-	-	-
Stage 2	316	-	-	-	-	-

Approach	EB	NB	SB
HCM Control Delay, s	16.2	2	0
HCM LOS	C		

Minor Lane/Major Mvmt	NBL	NBT	EBLn1	SBT	SBR
Capacity (veh/h)	1046	-	484	-	-
HCM Lane V/C Ratio	0.204	-	0.337	-	-
HCM Control Delay (s)	9.3	-	16.2	-	-
HCM Lane LOS	A	-	C	-	-
HCM 95th %tile Q(veh)	0.8	-	1.5	-	-

HCM 2010 Signalized Intersection Summary
 7: Sierra Ave & I-15 SB Ramps

Opening Year 2020 PM
 03/16/2018

												
Movement	EBL	EBT	EBR	WBL	WBT	WBR	NBL	NBT	NBR	SBL	SBT	SBR
Lane Configurations												
Traffic Volume (veh/h)	0	0	0	782	4	171	250	1033	0	0	469	423
Future Volume (veh/h)	0	0	0	782	4	171	250	1033	0	0	469	423
Number				7	4	14	1	6	16	5	2	12
Initial Q (Qb), veh				0	0	0	0	0	0	0	0	0
Ped-Bike Adj(A_pbT)				1.00		1.00	1.00		1.00	1.00		1.00
Parking Bus, Adj				1.00	1.00	1.00	1.00	1.00	1.00	1.00	1.00	1.00
Adj Sat Flow, veh/h/ln				1900	1900	1900	1900	1900	0	0	1900	1900
Adj Flow Rate, veh/h				844	0	184	269	1111	0	0	504	455
Adj No. of Lanes				2	0	1	1	2	0	0	2	1
Peak Hour Factor				0.93	0.93	0.93	0.93	0.93	0.93	0.93	0.93	0.93
Percent Heavy Veh, %				0	0	0	0	0	0	0	0	0
Cap, veh/h				968	0	432	291	2311	0	0	1591	712
Arrive On Green				0.27	0.00	0.27	0.32	1.00	0.00	0.00	0.44	0.44
Sat Flow, veh/h				3619	0	1615	1810	3705	0	0	3705	1615
Grp Volume(v), veh/h				844	0	184	269	1111	0	0	504	455
Grp Sat Flow(s),veh/h/ln				1810	0	1615	1810	1805	0	0	1805	1615
Q Serve(g_s), s				29.0	0.0	12.2	18.6	0.0	0.0	0.0	11.8	28.5
Cycle Q Clear(g_c), s				29.0	0.0	12.2	18.6	0.0	0.0	0.0	11.8	28.5
Prop In Lane				1.00		1.00	1.00		0.00	0.00		1.00
Lane Grp Cap(c), veh/h				968	0	432	291	2311	0	0	1591	712
V/C Ratio(X)				0.87	0.00	0.43	0.92	0.48	0.00	0.00	0.32	0.64
Avail Cap(c_a), veh/h				1336	0	596	418	2311	0	0	1591	712
HCM Platoon Ratio				1.00	1.00	1.00	2.00	2.00	1.00	1.00	1.00	1.00
Upstream Filter(I)				1.00	0.00	1.00	0.75	0.75	0.00	0.00	1.00	1.00
Uniform Delay (d), s/veh				45.5	0.0	39.4	43.3	0.0	0.0	0.0	23.6	28.3
Incr Delay (d2), s/veh				4.9	0.0	0.7	13.9	0.5	0.0	0.0	0.5	4.4
Initial Q Delay(d3),s/veh				0.0	0.0	0.0	0.0	0.0	0.0	0.0	0.0	0.0
%ile BackOfQ(50%),veh/ln				15.1	0.0	5.5	10.4	0.2	0.0	0.0	6.0	13.5
LnGrp Delay(d),s/veh				50.4	0.0	40.0	57.2	0.5	0.0	0.0	24.1	32.7
LnGrp LOS				D		D	E	A			C	C
Approach Vol, veh/h					1028			1380			959	
Approach Delay, s/veh					48.6			11.6			28.2	
Approach LOS					D			B			C	
Timer	1	2	3	4	5	6	7	8				
Assigned Phs	1	2		4		6						
Phs Duration (G+Y+Rc), s	25.9	63.3		40.8		89.2						
Change Period (Y+Rc), s	5.0	6.0		6.0		6.0						
Max Green Setting (Gmax), s	30.0	35.0		48.0		70.0						
Max Q Clear Time (g_c+I1), s	20.6	30.5		31.0		2.0						
Green Ext Time (p_c), s	0.3	3.8		3.8		24.4						
Intersection Summary												
HCM 2010 Ctrl Delay				27.6								
HCM 2010 LOS				C								
Notes												

HCM 2010 Signalized Intersection Summary
 8: Sierra Ave & I-15 NB Ramps

Opening Year 2020 PM
 03/16/2018



Movement	EBL	EBT	EBR	WBL	WBT	WBR	NBL	NBT	NBR	SBL	SBT	SBR
Lane Configurations												
Traffic Volume (veh/h)	739	0	499	0	0	0	0	544	965	208	1043	0
Future Volume (veh/h)	739	0	499	0	0	0	0	544	965	208	1043	0
Number	3	8	18				1	6	16	5	2	12
Initial Q (Qb), veh	0	0	0				0	0	0	0	0	0
Ped-Bike Adj(A_pbT)	1.00		1.00				1.00		1.00	1.00		1.00
Parking Bus, Adj	1.00	1.00	1.00				1.00	1.00	1.00	1.00	1.00	1.00
Adj Sat Flow, veh/h/ln	1900	1900	1900				0	1900	1900	1900	1900	0
Adj Flow Rate, veh/h	972	0	361				0	591	1049	226	1134	0
Adj No. of Lanes	2	0	1				0	2	1	1	2	0
Peak Hour Factor	0.92	0.92	0.92				0.92	0.92	0.92	0.92	0.92	0.92
Percent Heavy Veh, %	0	0	0				0	0	0	0	0	0
Cap, veh/h	1036	0	462				0	1612	721	247	2244	0
Arrive On Green	0.29	0.00	0.29				0.00	0.45	0.45	0.27	1.00	0.00
Sat Flow, veh/h	3619	0	1615				0	3705	1615	1810	3705	0
Grp Volume(v), veh/h	972	0	361				0	591	1049	226	1134	0
Grp Sat Flow(s),veh/h/ln	1810	0	1615				0	1805	1615	1810	1805	0
Q Serve(g_s), s	34.1	0.0	26.7				0.0	14.1	58.1	15.7	0.0	0.0
Cycle Q Clear(g_c), s	34.1	0.0	26.7				0.0	14.1	58.1	15.7	0.0	0.0
Prop In Lane	1.00		1.00				0.00		1.00	1.00		0.00
Lane Grp Cap(c), veh/h	1036	0	462				0	1612	721	247	2244	0
V/C Ratio(X)	0.94	0.00	0.78				0.00	0.37	1.45	0.92	0.51	0.00
Avail Cap(c_a), veh/h	1058	0	472				0	1612	721	251	2244	0
HCM Platoon Ratio	1.00	1.00	1.00				1.00	1.00	1.00	2.00	2.00	1.00
Upstream Filter(I)	1.00	0.00	1.00				0.00	0.25	0.25	0.81	0.81	0.00
Uniform Delay (d), s/veh	45.3	0.0	42.7				0.0	23.8	36.0	46.5	0.0	0.0
Incr Delay (d2), s/veh	15.0	0.0	8.1				0.0	0.2	206.5	29.4	0.7	0.0
Initial Q Delay(d3),s/veh	0.0	0.0	0.0				0.0	0.0	0.0	0.0	0.0	0.0
%ile BackOfQ(50%),veh/ln	19.2	0.0	13.0				0.0	7.0	67.2	9.8	0.2	0.0
LnGrp Delay(d),s/veh	60.3	0.0	50.8				0.0	24.0	242.5	75.9	0.7	0.0
LnGrp LOS	E		D					C	F	E	A	
Approach Vol, veh/h		1333						1640			1360	
Approach Delay, s/veh		57.7						163.7			13.2	
Approach LOS		E						F			B	
Timer	1	2	3	4	5	6	7	8				
Assigned Phs		2			5	6		8				
Phs Duration (G+Y+Rc), s		86.8			22.7	64.1		43.2				
Change Period (Y+Rc), s		6.0			5.0	6.0		6.0				
Max Green Setting (Gmax), s		80.0			18.0	57.0		38.0				
Max Q Clear Time (g_c+1), s		2.0			17.7	60.1		36.1				
Green Ext Time (p_c), s		42.2			0.0	0.0		1.1				
Intersection Summary												
HCM 2010 Ctrl Delay			83.8									
HCM 2010 LOS			F									
Notes												

HCM Signalized Intersection Capacity Analysis
9: Sierra Ave & Riverside Ave

Opening Year 2020 PM
03/16/2018



Movement	WBL	WBR	NBT	NBR	SBL	SBT
Lane Configurations						
Traffic Volume (vph)	21	646	863	20	648	894
Future Volume (vph)	21	646	863	20	648	894
Ideal Flow (vphpl)	1900	1900	1900	1900	1900	1900
Total Lost time (s)	8.0	8.0	8.0		7.0	8.0
Lane Util. Factor	1.00	1.00	0.95		1.00	0.95
Frt	1.00	0.85	1.00		1.00	1.00
Flt Protected	0.95	1.00	1.00		0.95	1.00
Satd. Flow (prot)	1805	1615	3598		1805	3610
Flt Permitted	0.95	1.00	1.00		0.95	1.00
Satd. Flow (perm)	1805	1615	3598		1805	3610
Peak-hour factor, PHF	0.94	0.94	0.94	0.94	0.94	0.94
Adj. Flow (vph)	22	687	918	21	689	951
RTOR Reduction (vph)	0	565	1	0	0	0
Lane Group Flow (vph)	22	122	938	0	689	951
Heavy Vehicles (%)	0%	0%	0%	0%	0%	0%
Turn Type	Perm	Perm	NA		Prot	NA
Protected Phases			6		5	2
Permitted Phases	4	4				
Actuated Green, G (s)	14.1	14.1	31.0		43.1	79.1
Effective Green, g (s)	12.1	12.1	29.0		41.1	77.1
Actuated g/C Ratio	0.12	0.12	0.28		0.39	0.73
Clearance Time (s)	6.0	6.0	6.0		5.0	6.0
Vehicle Extension (s)	3.0	3.0	3.0		3.0	3.0
Lane Grp Cap (vph)	207	185	991		705	2645
v/s Ratio Prot			c0.26		c0.38	0.26
v/s Ratio Perm	0.01	c0.08				
v/c Ratio	0.11	0.66	0.95		0.98	0.36
Uniform Delay, d1	41.7	44.6	37.3		31.6	5.1
Progression Factor	1.00	1.00	1.00		1.00	1.00
Incremental Delay, d2	0.2	8.6	17.0		28.0	0.1
Delay (s)	41.9	53.2	54.3		59.6	5.2
Level of Service	D	D	D		E	A
Approach Delay (s)	52.8		54.3			28.0
Approach LOS	D		D			C

Intersection Summary

HCM 2000 Control Delay	40.9	HCM 2000 Level of Service	D
HCM 2000 Volume to Capacity ratio	0.90		
Actuated Cycle Length (s)	105.2	Sum of lost time (s)	21.0
Intersection Capacity Utilization	87.9%	ICU Level of Service	E
Analysis Period (min)	15		
c Critical Lane Group			























Michael Baker
INTERNATIONAL

**Appendix F:
Opening Year 2020
With Project
Synchro Worksheets**

This page intentionally left blank

HCM 2010 Signalized Intersection Summary
 1: Cayote Canyon Rd & Duncan Canyon Rd

Opening Year W/ Project AM
 02/25/2019

												
Movement	EBL	EBT	EBR	WBL	WBT	WBR	NBL	NBT	NBR	SBL	SBT	SBR
Lane Configurations												
Traffic Volume (veh/h)	6	318	9	28	130	171	5	3	92	442	4	10
Future Volume (veh/h)	6	318	9	28	130	171	5	3	92	442	4	10
Number	5	2	12	1	6	16	3	8	18	7	4	14
Initial Q (Qb), veh	0	0	0	0	0	0	0	0	0	0	0	0
Ped-Bike Adj(A_pbT)	1.00		1.00	1.00		1.00	1.00		1.00	1.00		1.00
Parking Bus, Adj	1.00	1.00	1.00	1.00	1.00	1.00	1.00	1.00	1.00	1.00	1.00	1.00
Adj Sat Flow, veh/h/ln	1900	1900	1900	1900	1900	1900	1900	1900	1900	1900	1900	1900
Adj Flow Rate, veh/h	6	338	10	30	138	182	5	3	98	470	4	11
Adj No. of Lanes	1	2	0	1	2	0	1	1	1	1	1	1
Peak Hour Factor	0.94	0.94	0.94	0.94	0.94	0.94	0.94	0.94	0.94	0.94	0.94	0.94
Percent Heavy Veh, %	0	0	0	0	0	0	0	0	0	0	0	0
Cap, veh/h	14	696	21	62	398	356	0	192	218	557	585	497
Arrive On Green	0.01	0.19	0.19	0.03	0.22	0.22	0.10	0.10	0.10	0.31	0.31	0.31
Sat Flow, veh/h	1810	3581	106	1810	1805	1615	0	1900	1615	1810	1900	1615
Grp Volume(v), veh/h	6	170	178	30	138	182	0	3	98	470	4	11
Grp Sat Flow(s),veh/h/ln	1810	1805	1881	1810	1805	1615	0	1900	1615	1810	1900	1615
Q Serve(g_s), s	0.2	4.2	4.2	0.8	3.2	4.9	0.0	0.1	2.8	12.0	0.1	0.2
Cycle Q Clear(g_c), s	0.2	4.2	4.2	0.8	3.2	4.9	0.0	0.1	2.8	12.0	0.1	0.2
Prop In Lane	1.00		0.06	1.00		1.00	0.00		1.00	1.00		1.00
Lane Grp Cap(c), veh/h	14	351	366	62	398	356	0	192	218	557	585	497
V/C Ratio(X)	0.41	0.48	0.49	0.49	0.35	0.51	0.00	0.02	0.45	0.84	0.01	0.02
Avail Cap(c_a), veh/h	182	848	884	182	848	759	0	881	804	938	984	837
HCM Platoon Ratio	1.00	1.00	1.00	1.00	1.00	1.00	1.00	1.00	1.00	1.00	1.00	1.00
Upstream Filter(I)	1.00	1.00	1.00	1.00	1.00	1.00	0.00	1.00	1.00	1.00	1.00	1.00
Uniform Delay (d), s/veh	24.5	17.8	17.8	23.5	16.3	17.0	0.0	20.1	19.8	16.1	11.9	12.0
Incr Delay (d2), s/veh	17.8	1.0	1.0	5.8	0.5	1.1	0.0	0.0	1.4	3.6	0.0	0.0
Initial Q Delay(d3),s/veh	0.0	0.0	0.0	0.0	0.0	0.0	0.0	0.0	0.0	0.0	0.0	0.0
%ile BackOfQ(50%),veh/ln	0.2	2.2	2.3	0.5	1.6	2.3	0.0	0.0	1.3	6.6	0.0	0.1
LnGrp Delay(d),s/veh	42.3	18.8	18.8	29.3	16.8	18.1	0.0	20.1	21.2	19.7	11.9	12.0
LnGrp LOS	D	B	B	C	B	B		C	C	B	B	B
Approach Vol, veh/h		354			350			101			485	
Approach Delay, s/veh		19.2			18.6			21.2			19.4	
Approach LOS		B			B			C			B	
Timer	1	2	3	4	5	6	7	8				
Assigned Phs	1	2		4	5	6		8				
Phs Duration (G+Y+Rc), s	6.2	14.1		19.8	4.9	15.4		9.5				
Change Period (Y+Rc), s	4.5	4.5		4.5	4.5	4.5		* 4.5				
Max Green Setting (Gmax), s	5.0	23.3		25.7	5.0	23.3		* 23				
Max Q Clear Time (g_c+I1), s	2.8	6.2		14.0	2.2	6.9		4.8				
Green Ext Time (p_c), s	0.0	3.5		1.2	0.0	3.4		0.2				
Intersection Summary												
HCM 2010 Ctrl Delay			19.3									
HCM 2010 LOS			B									
Notes												

Intersection

Int Delay, s/veh 1.8

Movement EBT EBR WBL WBT NBL NBR

Lane Configurations						
Traffic Vol, veh/h	171	19	51	74	6	15
Future Vol, veh/h	171	19	51	74	6	15
Conflicting Peds, #/hr	0	0	0	0	0	0
Sign Control	Free	Free	Free	Free	Stop	Stop
RT Channelized	-	None	-	None	-	None
Storage Length	-	-	-	-	0	-
Veh in Median Storage, #	0	-	-	0	0	-
Grade, %	0	-	-	0	0	-
Peak Hour Factor	95	95	95	95	95	95
Heavy Vehicles, %	0	0	0	0	0	0
Mvmt Flow	180	20	54	78	6	16

Major/Minor Major1 Major2 Minor1

Conflicting Flow All	0	0	200	0	375	190
Stage 1	-	-	-	-	190	-
Stage 2	-	-	-	-	185	-
Critical Hdwy	-	-	4.1	-	6.4	6.2
Critical Hdwy Stg 1	-	-	-	-	5.4	-
Critical Hdwy Stg 2	-	-	-	-	5.4	-
Follow-up Hdwy	-	-	2.2	-	3.5	3.3
Pot Cap-1 Maneuver	-	-	1384	-	630	857
Stage 1	-	-	-	-	847	-
Stage 2	-	-	-	-	852	-
Platoon blocked, %	-	-	-	-	-	-
Mov Cap-1 Maneuver	-	-	1384	-	604	857
Mov Cap-2 Maneuver	-	-	-	-	604	-
Stage 1	-	-	-	-	847	-
Stage 2	-	-	-	-	817	-

Approach EB WB NB

HCM Control Delay, s	0	3.1	9.8
HCM LOS			A

Minor Lane/Major Mvmt NBLn1 EBT EBR WBL WBT

Capacity (veh/h)	765	-	-	1384	-
HCM Lane V/C Ratio	0.029	-	-	0.039	-
HCM Control Delay (s)	9.8	-	-	7.7	0
HCM Lane LOS	A	-	-	A	A
HCM 95th %tile Q(veh)	0.1	-	-	0.1	-

Intersection

Int Delay, s/veh 3.9

Movement	EBL	EBT	WBT	WBR	SBL	SBR
Lane Configurations		↶	↷		↶	
Traffic Vol, veh/h	0	66	178	109	171	0
Future Vol, veh/h	0	66	178	109	171	0
Conflicting Peds, #/hr	0	0	0	0	0	0
Sign Control	Free	Free	Free	Free	Stop	Stop
RT Channelized	-	None	-	None	-	None
Storage Length	-	-	-	-	0	-
Veh in Median Storage, #	-	0	0	-	0	-
Grade, %	-	0	0	-	0	-
Peak Hour Factor	95	95	95	95	95	95
Heavy Vehicles, %	0	0	0	0	0	0
Mvmt Flow	0	69	187	115	180	0











Major/Minor	Major1	Major2	Minor2
Conflicting Flow All	302	0	0 314 245
Stage 1	-	-	- - 245 -
Stage 2	-	-	- - 69 -
Critical Hdwy	4.1	-	- - 6.4 6.2
Critical Hdwy Stg 1	-	-	- - 5.4 -
Critical Hdwy Stg 2	-	-	- - 5.4 -
Follow-up Hdwy	2.2	-	- - 3.5 3.3
Pot Cap-1 Maneuver	1270	-	- - 683 799
Stage 1	-	-	- - 800 -
Stage 2	-	-	- - 959 -
Platoon blocked, %		-	- - -
Mov Cap-1 Maneuver	1270	-	- - 683 799
Mov Cap-2 Maneuver	-	-	- - 683 -
Stage 1	-	-	- - 800 -
Stage 2	-	-	- - 959 -

Approach	EB	WB	SB
HCM Control Delay, s	0	0	12.1
HCM LOS			B

Minor Lane/Major Mvmt	EBL	EBT	WBT	WBR	SBLn1
Capacity (veh/h)	1270	-	-	-	683
HCM Lane V/C Ratio	-	-	-	-	0.264
HCM Control Delay (s)	0	-	-	-	12.1
HCM Lane LOS	A	-	-	-	B
HCM 95th %tile Q(veh)	0	-	-	-	1.1

HCM 2010 Signalized Intersection Summary
6: Sierra Ave & Lytle Creek Rd (W/ Realignment)

Opening Year W/ Project AM
07/20/2018

								
Movement	EBL	EBR	NBL	NBT	SBT	SBR		
Lane Configurations								
Traffic Volume (veh/h)	2	223	268	369	1044	19		
Future Volume (veh/h)	2	223	268	369	1044	19		
Number	3	18	1	6	2	12		
Initial Q (Qb), veh	0	0	0	0	0	0		
Ped-Bike Adj(A_pbT)	1.00	1.00	1.00			1.00		
Parking Bus, Adj	1.00	1.00	1.00	1.00	1.00	1.00		
Adj Sat Flow, veh/h/ln	1900	1900	1900	1900	1900	1900		
Adj Flow Rate, veh/h	2	242	291	401	1135	21		
Adj No. of Lanes	0	0	1	2	2	0		
Peak Hour Factor	0.92	0.92	0.92	0.92	0.92	0.92		
Percent Heavy Veh, %	0	0	0	0	0	0		
Cap, veh/h	2	250	297	2311	1380	26		
Arrive On Green	0.16	0.18	0.16	0.64	0.38	0.41		
Sat Flow, veh/h	13	1598	1810	3705	3721	67		
Grp Volume(v), veh/h	245	0	291	401	565	591		
Grp Sat Flow(s),veh/h/ln	1617	0	1810	1805	1805	1888		
Q Serve(g_s), s	11.1	0.0	11.8	3.3	20.8	20.8		
Cycle Q Clear(g_c), s	11.1	0.0	11.8	3.3	20.8	20.8		
Prop In Lane	0.01	0.99	1.00			0.04		
Lane Grp Cap(c), veh/h	253	0	297	2311	687	719		
V/C Ratio(X)	0.97	0.00	0.98	0.17	0.82	0.82		
Avail Cap(c_a), veh/h	439	0	393	2695	784	820		
HCM Platoon Ratio	1.00	1.00	1.00	1.00	1.00	1.00		
Upstream Filter(I)	1.00	0.00	1.00	1.00	1.00	1.00		
Uniform Delay (d), s/veh	29.9	0.0	30.6	5.4	20.6	20.5		
Incr Delay (d2), s/veh	24.7	0.0	35.2	0.0	6.3	6.1		
Initial Q Delay(d3),s/veh	0.0	0.0	0.0	0.0	0.0	0.0		
%ile BackOfQ(50%),veh/ln	6.6	0.0	8.7	1.6	11.6	12.0		
LnGrp Delay(d),s/veh	54.6	0.0	65.8	5.4	26.9	26.6		
LnGrp LOS	D		E	A	C	C		
Approach Vol, veh/h	245			692	1156			
Approach Delay, s/veh	54.6			30.8	26.7			
Approach LOS	D			C	C			
Timer	1	2	3	4	5	6	7	8
Assigned Phs	1	2				6		8
Phs Duration (G+Y+Rc), s	19.1	35.0				54.2		19.5
Change Period (Y+Rc), s	5.0	5.0				5.0		6.0
Max Green Setting (Gmax), s	18.0	34.0				57.0		22.0
Max Q Clear Time (g_c+I1), s	13.8	22.8				5.3		13.1
Green Ext Time (p_c), s	0.4	7.3				15.8		0.5
Intersection Summary								
HCM 2010 Ctrl Delay			31.3					
HCM 2010 LOS			C					
Notes								
User approved volume balancing among the lanes for turning movement.								

HCM 2010 Signalized Intersection Summary
7: Sierra Ave & I-15 SB Ramps

Opening Year W/ Project AM
03/16/2018



Movement	EBL	EBT	EBR	WBL	WBT	WBR	NBL	NBT	NBR	SBL	SBT	SBR
Lane Configurations				↖	↖	↖	↖	↖↖			↖↖	↖
Traffic Volume (veh/h)	0	0	0	702	0	261	543	615	0	0	498	956
Future Volume (veh/h)	0	0	0	702	0	261	543	615	0	0	498	956
Number				7	4	14	1	6	16	5	2	12
Initial Q (Qb), veh				0	0	0	0	0	0	0	0	0
Ped-Bike Adj(A_pbT)				1.00		1.00	1.00		1.00	1.00		1.00
Parking Bus, Adj				1.00	1.00	1.00	1.00	1.00	1.00	1.00	1.00	1.00
Adj Sat Flow, veh/h/ln				1900	1900	1900	1900	1900	0	0	1900	1900
Adj Flow Rate, veh/h				789	0	293	610	691	0	0	560	1074
Adj No. of Lanes				2	0	1	1	2	0	0	2	1
Peak Hour Factor				0.89	0.89	0.89	0.89	0.89	0.89	0.89	0.89	0.89
Percent Heavy Veh, %				0	0	0	0	0	0	0	0	0
Cap, veh/h				752	0	335	515	2527	0	0	1361	609
Arrive On Green				0.21	0.00	0.21	0.57	1.00	0.00	0.00	0.38	0.38
Sat Flow, veh/h				3619	0	1615	1810	3705	0	0	3705	1615
Grp Volume(v), veh/h				789	0	293	610	691	0	0	560	1074
Grp Sat Flow(s),veh/h/ln				1810	0	1615	1810	1805	0	0	1805	1615
Q Serve(g_s), s				27.0	0.0	22.8	37.0	0.0	0.0	0.0	14.9	49.0
Cycle Q Clear(g_c), s				27.0	0.0	22.8	37.0	0.0	0.0	0.0	14.9	49.0
Prop In Lane				1.00		1.00	1.00		0.00	0.00		1.00
Lane Grp Cap(c), veh/h				752	0	335	515	2527	0	0	1361	609
V/C Ratio(X)				1.05	0.00	0.87	1.18	0.27	0.00	0.00	0.41	1.76
Avail Cap(c_a), veh/h				752	0	335	515	2527	0	0	1361	609
HCM Platoon Ratio				1.00	1.00	1.00	2.00	2.00	1.00	1.00	1.00	1.00
Upstream Filter(I)				1.00	0.00	1.00	0.85	0.85	0.00	0.00	0.38	0.38
Uniform Delay (d), s/veh				51.5	0.0	49.8	28.0	0.0	0.0	0.0	29.9	40.5
Incr Delay (d2), s/veh				46.6	0.0	21.6	99.0	0.2	0.0	0.0	0.4	346.5
Initial Q Delay(d3),s/veh				0.0	0.0	0.0	0.0	0.0	0.0	0.0	0.0	0.0
%ile BackOfQ(50%),veh/ln				18.3	0.0	12.2	32.2	0.1	0.0	0.0	7.5	80.4
LnGrp Delay(d),s/veh				98.1	0.0	71.4	127.0	0.2	0.0	0.0	30.2	387.0
LnGrp LOS				F		E	F	A			C	F
Approach Vol, veh/h					1082			1301			1634	
Approach Delay, s/veh					90.9			59.7			264.7	
Approach LOS					F			E			F	
Timer	1	2	3	4	5	6	7	8				
Assigned Phs	1	2		4		6						
Phs Duration (G+Y+Rc), s	42.0	55.0		33.0		97.0						
Change Period (Y+Rc), s	5.0	6.0		6.0		6.0						
Max Green Setting (Gmax), s	47.0	49.0		27.0		91.0						
Max Q Clear Time (g_c+Rc), s	49.0	51.0		29.0		2.0						
Green Ext Time (p_c), s	0.0	0.0		0.0		29.9						
Intersection Summary												
HCM 2010 Ctrl Delay				151.5								
HCM 2010 LOS				F								
Notes												

HCM 2010 Signalized Intersection Summary
 8: Sierra Ave & I-15 NB Ramps

Opening Year W/ Project AM
 03/16/2018



Movement	EBL	EBT	EBR	WBL	WBT	WBR	NBL	NBT	NBR	SBL	SBT	SBR
Lane Configurations												
Traffic Volume (veh/h)	374	0	238	0	0	0	0	784	673	167	1033	0
Future Volume (veh/h)	374	0	238	0	0	0	0	784	673	167	1033	0
Number	3	8	18				1	6	16	5	2	12
Initial Q (Qb), veh	0	0	0				0	0	0	0	0	0
Ped-Bike Adj(A_pbT)	1.00		1.00				1.00		1.00	1.00		1.00
Parking Bus, Adj	1.00	1.00	1.00				1.00	1.00	1.00	1.00	1.00	1.00
Adj Sat Flow, veh/h/ln	1900	1900	1900				0	1900	1900	1900	1900	0
Adj Flow Rate, veh/h	503	0	178				0	881	756	188	1161	0
Adj No. of Lanes	2	0	1				0	2	1	1	2	0
Peak Hour Factor	0.89	0.89	0.89				0.89	0.89	0.89	0.89	0.89	0.89
Percent Heavy Veh, %	0	0	0				0	0	0	0	0	0
Cap, veh/h	598	0	267				0	2120	948	212	2681	0
Arrive On Green	0.17	0.00	0.17				0.00	0.59	0.59	0.23	1.00	0.00
Sat Flow, veh/h	3619	0	1615				0	3705	1615	1810	3705	0
Grp Volume(v), veh/h	503	0	178				0	881	756	188	1161	0
Grp Sat Flow(s),veh/h/ln	1810	0	1615				0	1805	1615	1810	1805	0
Q Serve(g_s), s	17.5	0.0	13.4				0.0	17.3	47.2	13.1	0.0	0.0
Cycle Q Clear(g_c), s	17.5	0.0	13.4				0.0	17.3	47.2	13.1	0.0	0.0
Prop In Lane	1.00		1.00				0.00		1.00	1.00		0.00
Lane Grp Cap(c), veh/h	598	0	267				0	2120	948	212	2681	0
V/C Ratio(X)	0.84	0.00	0.67				0.00	0.42	0.80	0.89	0.43	0.00
Avail Cap(c_a), veh/h	835	0	373				0	2120	948	320	2681	0
HCM Platoon Ratio	1.00	1.00	1.00				1.00	1.00	1.00	2.00	2.00	1.00
Upstream Filter(I)	1.00	0.00	1.00				0.00	0.24	0.24	0.67	0.67	0.00
Uniform Delay (d), s/veh	52.6	0.0	50.9				0.0	14.7	20.8	49.0	0.0	0.0
Incr Delay (d2), s/veh	5.6	0.0	2.9				0.0	0.1	1.8	9.2	0.3	0.0
Initial Q Delay(d3),s/veh	0.0	0.0	0.0				0.0	0.0	0.0	0.0	0.0	0.0
%ile BackOfQ(50%),veh/ln	9.2	0.0	6.2				0.0	8.6	21.5	7.0	0.1	0.0
LnGrp Delay(d),s/veh	58.2	0.0	53.8				0.0	14.8	22.6	58.2	0.3	0.0
LnGrp LOS	E		D					B	C	E	A	
Approach Vol, veh/h		681						1637			1349	
Approach Delay, s/veh		57.0						18.4			8.4	
Approach LOS		E						B			A	
Timer	1	2	3	4	5	6	7	8				
Assigned Phs		2			5	6		8				
Phs Duration (G+Y+Rc), s		102.5			20.2	82.3		27.5				
Change Period (Y+Rc), s		6.0			5.0	6.0		6.0				
Max Green Setting (Gmax), s		88.0			23.0	60.0		30.0				
Max Q Clear Time (g_c+I1), s		2.0			15.1	49.2		19.5				
Green Ext Time (p_c), s		45.3			0.2	9.6		2.0				
Intersection Summary												
HCM 2010 Ctrl Delay			21.9									
HCM 2010 LOS			C									
Notes												

HCM Signalized Intersection Capacity Analysis

9: Sierra Ave & Riverside Ave

Opening Year W/ Project AM

03/16/2018

























Movement	WBL	WBR	NBT	NBR	SBL	SBT
Lane Configurations						
Traffic Volume (vph)	43	651	806	37	569	702
Future Volume (vph)	43	651	806	37	569	702
Ideal Flow (vphpl)	1900	1900	1900	1900	1900	1900
Total Lost time (s)	6.5	6.5	8.0		7.0	8.0
Lane Util. Factor	1.00	1.00	0.95		1.00	0.95
Frt	1.00	0.85	0.99		1.00	1.00
Flt Protected	0.95	1.00	1.00		0.95	1.00
Satd. Flow (prot)	1805	1615	3586		1805	3610
Flt Permitted	0.95	1.00	1.00		0.95	1.00
Satd. Flow (perm)	1805	1615	3586		1805	3610
Peak-hour factor, PHF	0.92	0.92	0.92	0.92	0.92	0.92
Adj. Flow (vph)	47	708	876	40	618	763
RTOR Reduction (vph)	0	523	3	0	0	0
Lane Group Flow (vph)	47	185	913	0	618	763
Heavy Vehicles (%)	0%	0%	0%	0%	0%	0%
Turn Type	Perm	Perm	NA		Prot	NA
Protected Phases			6		5	2
Permitted Phases	4	4				
Actuated Green, G (s)	15.6	15.6	28.3		36.1	69.4
Effective Green, g (s)	13.6	13.6	26.3		34.1	67.4
Actuated g/C Ratio	0.14	0.14	0.28		0.36	0.71
Clearance Time (s)	4.5	4.5	6.0		5.0	6.0
Vehicle Extension (s)	3.0	3.0	3.0		3.0	3.0
Lane Grp Cap (vph)	257	229	987		644	2547
v/s Ratio Prot			c0.25		c0.34	0.21
v/s Ratio Perm	0.03	c0.11				
v/c Ratio	0.18	0.81	0.93		0.96	0.30
Uniform Delay, d1	36.1	39.7	33.6		30.0	5.2
Progression Factor	1.00	1.00	1.00		1.00	1.00
Incremental Delay, d2	0.3	18.5	13.9		25.5	0.1
Delay (s)	36.4	58.1	47.6		55.5	5.3
Level of Service	D	E	D		E	A
Approach Delay (s)	56.8		47.6			27.8
Approach LOS	E		D			C

Intersection Summary

HCM 2000 Control Delay	40.9	HCM 2000 Level of Service	D
HCM 2000 Volume to Capacity ratio	0.89		
Actuated Cycle Length (s)	95.5	Sum of lost time (s)	19.5
Intersection Capacity Utilization	77.1%	ICU Level of Service	D
Analysis Period (min)	15		
c Critical Lane Group			

HCM 2010 Signalized Intersection Summary
 1: Cayote Canyon Rd & Duncan Canyon Rd

Opening Year W/ Project PM
 02/25/2019

												
Movement	EBL	EBT	EBR	WBL	WBT	WBR	NBL	NBT	NBR	SBL	SBT	SBR
Lane Configurations												
Traffic Volume (veh/h)	15	201	10	122	280	479	9	1	75	319	0	4
Future Volume (veh/h)	15	201	10	122	280	479	9	1	75	319	0	4
Number	5	2	12	1	6	16	3	8	18	7	4	14
Initial Q (Qb), veh	0	0	0	0	0	0	0	0	0	0	0	0
Ped-Bike Adj(A_pbT)	1.00		1.00	1.00		1.00	1.00		1.00	1.00		1.00
Parking Bus, Adj	1.00	1.00	1.00	1.00	1.00	1.00	1.00	1.00	1.00	1.00	1.00	1.00
Adj Sat Flow, veh/h/ln	1900	1900	1900	1900	1900	1900	1900	1900	1900	1900	1900	1900
Adj Flow Rate, veh/h	17	231	11	140	322	551	10	1	86	367	0	5
Adj No. of Lanes	1	2	0	1	2	0	1	1	1	1	1	1
Peak Hour Factor	0.87	0.87	0.87	0.87	0.87	0.87	0.87	0.87	0.87	0.87	0.87	0.87
Percent Heavy Veh, %	0	0	0	0	0	0	0	0	0	0	0	0
Cap, veh/h	37	971	46	179	640	573	0	160	296	427	448	381
Arrive On Green	0.02	0.28	0.28	0.10	0.35	0.35	0.08	0.08	0.08	0.24	0.00	0.24
Sat Flow, veh/h	1810	3509	166	1810	1805	1615	0	1900	1615	1810	1900	1615
Grp Volume(v), veh/h	17	118	124	140	322	551	0	1	86	367	0	5
Grp Sat Flow(s),veh/h/ln	1810	1805	1871	1810	1805	1615	0	1900	1615	1810	1900	1615
Q Serve(g_s), s	0.5	3.0	3.0	4.5	8.3	19.8	0.0	0.0	2.7	11.5	0.0	0.1
Cycle Q Clear(g_c), s	0.5	3.0	3.0	4.5	8.3	19.8	0.0	0.0	2.7	11.5	0.0	0.1
Prop In Lane	1.00		0.09	1.00		1.00	0.00		1.00	1.00		1.00
Lane Grp Cap(c), veh/h	37	499	517	179	640	573	0	160	296	427	448	381
V/C Ratio(X)	0.46	0.24	0.24	0.78	0.50	0.96	0.00	0.01	0.29	0.86	0.00	0.01
Avail Cap(c_a), veh/h	153	570	591	223	640	573	0	578	651	550	578	491
HCM Platoon Ratio	1.00	1.00	1.00	1.00	1.00	1.00	1.00	1.00	1.00	1.00	1.00	1.00
Upstream Filter(I)	1.00	1.00	1.00	1.00	1.00	1.00	0.00	1.00	1.00	1.00	0.00	1.00
Uniform Delay (d), s/veh	28.7	16.6	16.6	26.1	15.0	18.7	0.0	24.8	20.9	21.7	0.0	17.3
Incr Delay (d2), s/veh	8.5	0.2	0.2	13.3	0.6	28.1	0.0	0.0	0.5	10.5	0.0	0.0
Initial Q Delay(d3),s/veh	0.0	0.0	0.0	0.0	0.0	0.0	0.0	0.0	0.0	0.0	0.0	0.0
%ile BackOfQ(50%),veh/ln	0.4	1.5	1.6	2.9	4.2	13.2	0.0	0.0	1.2	7.0	0.0	0.1
LnGrp Delay(d),s/veh	37.1	16.8	16.8	39.3	15.6	46.8	0.0	24.8	21.4	32.2	0.0	17.3
LnGrp LOS	D	B	B	D	B	D		C	C	C		B
Approach Vol, veh/h		259			1013			87				372
Approach Delay, s/veh		18.2			35.9			21.4				32.0
Approach LOS		B			D			C				C
Timer	1	2	3	4	5	6	7	8				
Assigned Phs	1	2		4	5	6		8				
Phs Duration (G+Y+Rc), s	10.3	20.9		18.5	5.7	25.5		9.5				
Change Period (Y+Rc), s	4.5	4.5		4.5	4.5	4.5		* 4.5				
Max Green Setting (Gmax), s	7.3	18.7		18.0	5.0	21.0		* 18				
Max Q Clear Time (g_c+1), s	6.5	5.0		13.5	2.5	21.8		4.7				
Green Ext Time (p_c), s	0.0	5.8		0.5	0.0	0.0		0.2				
Intersection Summary												
HCM 2010 Ctrl Delay				31.7								
HCM 2010 LOS				C								
Notes												

Intersection

Int Delay, s/veh 2

Movement	EBT	EBR	WBL	WBT	NBL	NBR
Lane Configurations						
Traffic Vol, veh/h	154	8	20	184	20	54
Future Vol, veh/h	154	8	20	184	20	54
Conflicting Peds, #/hr	0	0	0	0	0	0
Sign Control	Free	Free	Free	Free	Stop	Stop
RT Channelized	-	None	-	None	-	None
Storage Length	-	-	-	-	0	-
Veh in Median Storage, #	0	-	-	0	0	-
Grade, %	0	-	-	0	0	-
Peak Hour Factor	95	95	95	95	95	95
Heavy Vehicles, %	0	0	0	0	0	0
Mvmt Flow	162	8	21	194	21	57

Major/Minor	Major1	Major2	Minor1		
Conflicting Flow All	0	0	171	0	402
Stage 1	-	-	-	-	166
Stage 2	-	-	-	-	236
Critical Hdwy	-	-	4.1	-	6.4
Critical Hdwy Stg 1	-	-	-	-	5.4
Critical Hdwy Stg 2	-	-	-	-	5.4
Follow-up Hdwy	-	-	2.2	-	3.5
Pot Cap-1 Maneuver	-	-	1418	-	608
Stage 1	-	-	-	-	868
Stage 2	-	-	-	-	808
Platoon blocked, %	-	-	-	-	-
Mov Cap-1 Maneuver	-	-	1418	-	598
Mov Cap-2 Maneuver	-	-	-	-	598
Stage 1	-	-	-	-	868
Stage 2	-	-	-	-	794

Approach	EB	WB	NB
HCM Control Delay, s	0	0.7	10.1
HCM LOS			B

Minor Lane/Major Mvmt	NBLn1	EBT	EBR	WBL	WBT
Capacity (veh/h)	783	-	-	1418	-
HCM Lane V/C Ratio	0.099	-	-	0.015	-
HCM Control Delay (s)	10.1	-	-	7.6	0
HCM Lane LOS	B	-	-	A	A
HCM 95th %tile Q(veh)	0.3	-	-	0	-

Intersection

Int Delay, s/veh 3.5

Movement	EBL	EBT	WBT	WBR	SBL	SBR
Lane Configurations		↶	↷		↶	
Traffic Vol, veh/h	0	214	68	198	170	0
Future Vol, veh/h	0	214	68	198	170	0
Conflicting Peds, #/hr	0	0	0	0	0	0
Sign Control	Free	Free	Free	Free	Stop	Stop
RT Channelized	-	None	-	None	-	None
Storage Length	-	-	-	-	0	-
Veh in Median Storage, #	-	0	0	-	0	-
Grade, %	-	0	0	-	0	-
Peak Hour Factor	95	95	95	95	95	95
Heavy Vehicles, %	0	0	0	0	0	0
Mvmt Flow	0	225	72	208	179	0

Major/Minor

	Major1	Major2	Minor2
Conflicting Flow All	280	0	401
Stage 1	-	-	176
Stage 2	-	-	225
Critical Hdwy	4.1	-	6.4
Critical Hdwy Stg 1	-	-	5.4
Critical Hdwy Stg 2	-	-	5.4
Follow-up Hdwy	2.2	-	3.5
Pot Cap-1 Maneuver	1294	-	609
Stage 1	-	-	859
Stage 2	-	-	817
Platoon blocked, %	-	-	-
Mov Cap-1 Maneuver	1294	-	609
Mov Cap-2 Maneuver	-	-	609
Stage 1	-	-	859
Stage 2	-	-	817

Approach











	EB	WB	SB
HCM Control Delay, s	0	0	13.4
HCM LOS			B

Minor Lane/Major Mvmt

	EBL	EBT	WBT	WBR	SBLn1
Capacity (veh/h)	1294	-	-	-	609
HCM Lane V/C Ratio	-	-	-	-	0.294
HCM Control Delay (s)	0	-	-	-	13.4
HCM Lane LOS	A	-	-	-	B
HCM 95th %tile Q(veh)	0	-	-	-	1.2

HCM 2010 Signalized Intersection Summary
 6: Sierra Ave & Lytle Creek Rd (W/ Realignment)

Opening Year W/ Project PM
 07/20/2018

								
Movement	EBL	EBR	NBL	NBT	SBT	SBR		
Lane Configurations								
Traffic Volume (veh/h)	6	342	260	775	524	5		
Future Volume (veh/h)	6	342	260	775	524	5		
Number	3	18	1	6	2	12		
Initial Q (Qb), veh	0	0	0	0	0	0		
Ped-Bike Adj(A_pbT)	1.00	1.00	1.00			1.00		
Parking Bus, Adj	1.00	1.00	1.00	1.00	1.00	1.00		
Adj Sat Flow, veh/h/ln	1900	1900	1900	1900	1900	1900		
Adj Flow Rate, veh/h	6	360	274	816	552	5		
Adj No. of Lanes	0	0	1	2	2	0		
Peak Hour Factor	0.95	0.95	0.95	0.95	0.95	0.95		
Percent Heavy Veh, %	0	0	0	0	0	0		
Cap, veh/h	6	377	288	1839	879	8		
Arrive On Green	0.24	0.27	0.16	0.51	0.24	0.27		
Sat Flow, veh/h	26	1588	1810	3705	3761	33		
Grp Volume(v), veh/h	367	0	274	816	272	285		
Grp Sat Flow(s),veh/h/ln	1619	0	1810	1805	1805	1894		
Q Serve(g_s), s	14.1	0.0	9.5	9.1	8.5	8.5		
Cycle Q Clear(g_c), s	14.1	0.0	9.5	9.1	8.5	8.5		
Prop In Lane	0.02	0.98	1.00			0.02		
Lane Grp Cap(c), veh/h	384	0	288	1839	433	454		
V/C Ratio(X)	0.95	0.00	0.95	0.44	0.63	0.63		
Avail Cap(c_a), veh/h	614	0	658	2855	571	599		
HCM Platoon Ratio	1.00	1.00	1.00	1.00	1.00	1.00		
Upstream Filter(I)	1.00	0.00	1.00	1.00	1.00	1.00		
Uniform Delay (d), s/veh	22.8	0.0	26.3	9.8	21.5	21.5		
Incr Delay (d2), s/veh	18.9	0.0	15.6	0.2	1.5	1.4		
Initial Q Delay(d3),s/veh	0.0	0.0	0.0	0.0	0.0	0.0		
%ile BackOfQ(50%),veh/ln	8.3	0.0	6.0	4.5	4.4	4.6		
LnGrp Delay(d),s/veh	41.7	0.0	42.0	10.0	23.0	22.9		
LnGrp LOS	D		D	A	C	C		
Approach Vol, veh/h	367			1090	557			
Approach Delay, s/veh	41.7			18.0	23.0			
Approach LOS	D			B	C			
Timer	1	2	3	4	5	6	7	8
Assigned Phs	1	2				6		8
Phs Duration (G+Y+Rc), s	17.1	23.2				40.2		23.0
Change Period (Y+Rc), s	5.0	6.0				6.0		6.0
Max Green Setting (Gmax), s	25.0	22.0				52.0		26.0
Max Q Clear Time (g_c+I1), s	11.5	10.5				11.1		16.1
Green Ext Time (p_c), s	0.7	6.6				12.3		0.9
Intersection Summary								
HCM 2010 Ctrl Delay			23.7					
HCM 2010 LOS			C					
Notes								
User approved volume balancing among the lanes for turning movement.								

HCM 2010 Signalized Intersection Summary
7: Sierra Ave & I-15 SB Ramps

Opening Year W/ Project PM
03/16/2018



Movement	EBL	EBT	EBR	WBL	WBT	WBR	NBL	NBT	NBR	SBL	SBT	SBR
Lane Configurations				↖	↖	↖	↖	↖↖			↖↖	↖
Traffic Volume (veh/h)	0	0	0	782	4	200	250	1083	0	0	591	526
Future Volume (veh/h)	0	0	0	782	4	200	250	1083	0	0	591	526
Number				7	4	14	1	6	16	5	2	12
Initial Q (Qb), veh				0	0	0	0	0	0	0	0	0
Ped-Bike Adj(A_pbT)				1.00		1.00	1.00		1.00	1.00		1.00
Parking Bus, Adj				1.00	1.00	1.00	1.00	1.00	1.00	1.00	1.00	1.00
Adj Sat Flow, veh/h/ln				1900	1900	1900	1900	1900	0	0	1900	1900
Adj Flow Rate, veh/h				844	0	215	269	1165	0	0	635	566
Adj No. of Lanes				2	0	1	1	2	0	0	2	1
Peak Hour Factor				0.93	0.93	0.93	0.93	0.93	0.93	0.93	0.93	0.93
Percent Heavy Veh, %				0	0	0	0	0	0	0	0	0
Cap, veh/h				968	0	432	291	2312	0	0	1592	712
Arrive On Green				0.27	0.00	0.27	0.32	1.00	0.00	0.00	0.44	0.44
Sat Flow, veh/h				3619	0	1615	1810	3705	0	0	3705	1615
Grp Volume(v), veh/h				844	0	215	269	1165	0	0	635	566
Grp Sat Flow(s),veh/h/ln				1810	0	1615	1810	1805	0	0	1805	1615
Q Serve(g_s), s				29.0	0.0	14.6	18.6	0.0	0.0	0.0	15.5	39.2
Cycle Q Clear(g_c), s				29.0	0.0	14.6	18.6	0.0	0.0	0.0	15.5	39.2
Prop In Lane				1.00		1.00	1.00		0.00	0.00		1.00
Lane Grp Cap(c), veh/h				968	0	432	291	2312	0	0	1592	712
V/C Ratio(X)				0.87	0.00	0.50	0.92	0.50	0.00	0.00	0.40	0.79
Avail Cap(c_a), veh/h				1286	0	574	418	2312	0	0	1592	712
HCM Platoon Ratio				1.00	1.00	1.00	2.00	2.00	1.00	1.00	1.00	1.00
Upstream Filter(I)				1.00	0.00	1.00	0.70	0.70	0.00	0.00	0.70	0.70
Uniform Delay (d), s/veh				45.5	0.0	40.2	43.3	0.0	0.0	0.0	24.7	31.3
Incr Delay (d2), s/veh				5.4	0.0	0.9	13.1	0.6	0.0	0.0	0.5	6.4
Initial Q Delay(d3),s/veh				0.0	0.0	0.0	0.0	0.0	0.0	0.0	0.0	0.0
%ile BackOfQ(50%),veh/ln				15.1	0.0	6.6	10.3	0.2	0.0	0.0	7.9	18.7
LnGrp Delay(d),s/veh				50.9	0.0	41.1	56.4	0.6	0.0	0.0	25.2	37.7
LnGrp LOS				D		D	E	A			C	D
Approach Vol, veh/h					1059			1434			1201	
Approach Delay, s/veh					48.9			11.0			31.1	
Approach LOS					D			B			C	
Timer	1	2	3	4	5	6	7	8				
Assigned Phs	1	2		4		6						
Phs Duration (G+Y+Rc), s	35.9	63.3		40.8		89.2						
Change Period (Y+Rc), s	5.0	6.0		6.0		6.0						
Max Green Setting (Gmax), s	30.0	36.8		46.2		71.8						
Max Q Clear Time (g_c+20), s	20.6	41.2		31.0		2.0						
Green Ext Time (p_c), s	0.3	0.0		3.8		31.0						
Intersection Summary												
HCM 2010 Ctrl Delay				28.4								
HCM 2010 LOS				C								
Notes												

HCM 2010 Signalized Intersection Summary
 8: Sierra Ave & I-15 NB Ramps

Opening Year W/ Project PM
 03/16/2018



Movement	EBL	EBT	EBR	WBL	WBT	WBR	NBL	NBT	NBR	SBL	SBT	SBR
Lane Configurations												
Traffic Volume (veh/h)	775	0	499	0	0	0	0	558	965	290	1083	0
Future Volume (veh/h)	775	0	499	0	0	0	0	558	965	290	1083	0
Number	3	8	18				1	6	16	5	2	12
Initial Q (Qb), veh	0	0	0				0	0	0	0	0	0
Ped-Bike Adj(A_pbT)	1.00		1.00				1.00		1.00	1.00		1.00
Parking Bus, Adj	1.00	1.00	1.00				1.00	1.00	1.00	1.00	1.00	1.00
Adj Sat Flow, veh/h/ln	1900	1900	1900				0	1900	1900	1900	1900	0
Adj Flow Rate, veh/h	1011	0	361				0	607	1049	315	1177	0
Adj No. of Lanes	2	0	1				0	2	1	1	2	0
Peak Hour Factor	0.92	0.92	0.92				0.92	0.92	0.92	0.92	0.92	0.92
Percent Heavy Veh, %	0	0	0				0	0	0	0	0	0
Cap, veh/h	1030	0	460				0	1472	658	320	2249	0
Arrive On Green	0.28	0.00	0.28				0.00	0.41	0.41	0.35	1.00	0.00
Sat Flow, veh/h	3619	0	1615				0	3705	1615	1810	3705	0
Grp Volume(v), veh/h	1011	0	361				0	607	1049	315	1177	0
Grp Sat Flow(s),veh/h/ln	1810	0	1615				0	1805	1615	1810	1805	0
Q Serve(g_s), s	36.1	0.0	26.8				0.0	15.6	53.0	22.4	0.0	0.0
Cycle Q Clear(g_c), s	36.1	0.0	26.8				0.0	15.6	53.0	22.4	0.0	0.0
Prop In Lane	1.00		1.00				0.00		1.00	1.00		0.00
Lane Grp Cap(c), veh/h	1030	0	460				0	1472	658	320	2249	0
V/C Ratio(X)	0.98	0.00	0.79				0.00	0.41	1.59	0.98	0.52	0.00
Avail Cap(c_a), veh/h	1030	0	460				0	1472	658	320	2249	0
HCM Platoon Ratio	1.00	1.00	1.00				1.00	1.00	1.00	2.00	2.00	1.00
Upstream Filter(I)	1.00	0.00	1.00				0.00	0.18	0.18	0.77	0.77	0.00
Uniform Delay (d), s/veh	46.2	0.0	42.8				0.0	27.4	38.5	41.8	0.0	0.0
Incr Delay (d2), s/veh	23.5	0.0	8.7				0.0	0.2	268.3	39.8	0.7	0.0
Initial Q Delay(d3),s/veh	0.0	0.0	0.0				0.0	0.0	0.0	0.0	0.0	0.0
%ile BackOfQ(50%),veh/ln	11.3	0.0	13.0				0.0	7.8	72.7	14.6	0.2	0.0
LnGrp Delay(d),s/veh	69.7	0.0	51.6				0.0	27.6	306.8	81.6	0.7	0.0
LnGrp LOS	E		D					C	F	F	A	
Approach Vol, veh/h		1372						1656			1492	
Approach Delay, s/veh		64.9						204.4			17.8	
Approach LOS		E						F			B	

Timer	1	2	3	4	5	6	7	8
Assigned Phs		2			5	6		8
Phs Duration (G+Y+Rc), s		87.0			28.0	59.0		43.0
Change Period (Y+Rc), s		6.0			5.0	6.0		6.0
Max Green Setting (Gmax), s		81.0			23.0	53.0		37.0
Max Q Clear Time (g_c+I1), s		2.0			24.4	55.0		38.1
Green Ext Time (p_c), s		44.2			0.0	0.0		0.0

Intersection Summary		
HCM 2010 Ctrl Delay		100.5
HCM 2010 LOS		F

Notes

HCM Signalized Intersection Capacity Analysis
9: Sierra Ave & Riverside Ave

Opening Year W/ Project PM
03/16/2018



Movement	WBL	WBR	NBT	NBR	SBL	SBT
Lane Configurations						
Traffic Volume (vph)	21	655	868	20	674	908
Future Volume (vph)	21	655	868	20	674	908
Ideal Flow (vphpl)	1900	1900	1900	1900	1900	1900
Total Lost time (s)	6.5	6.5	8.0		7.0	8.0
Lane Util. Factor	1.00	1.00	0.95		1.00	0.95
Frt	1.00	0.85	1.00		1.00	1.00
Flt Protected	0.95	1.00	1.00		0.95	1.00
Satd. Flow (prot)	1805	1615	3598		1805	3610
Flt Permitted	0.95	1.00	1.00		0.95	1.00
Satd. Flow (perm)	1805	1615	3598		1805	3610
Peak-hour factor, PHF	0.94	0.94	0.94	0.94	0.94	0.94
Adj. Flow (vph)	22	697	923	21	717	966
RTOR Reduction (vph)	0	575	1	0	0	0
Lane Group Flow (vph)	22	122	943	0	717	966
Heavy Vehicles (%)	0%	0%	0%	0%	0%	0%
Turn Type	Perm	Perm	NA		Prot	NA
Protected Phases			6		5	2
Permitted Phases	4	4				
Actuated Green, G (s)	12.7	12.7	27.0		39.2	71.2
Effective Green, g (s)	10.7	10.7	25.0		37.2	69.2
Actuated g/C Ratio	0.11	0.11	0.26		0.39	0.73
Clearance Time (s)	4.5	4.5	6.0		5.0	6.0
Vehicle Extension (s)	3.0	3.0	3.0		3.0	3.0
Lane Grp Cap (vph)	204	183	952		711	2646
v/s Ratio Prot			c0.26		c0.40	0.27
v/s Ratio Perm	0.01	c0.08				
v/c Ratio	0.11	0.66	0.99		1.01	0.37
Uniform Delay, d1	37.6	40.1	34.6		28.6	4.6
Progression Factor	1.00	1.00	1.00		1.00	1.00
Incremental Delay, d2	0.2	8.8	26.6		35.8	0.1
Delay (s)	37.8	48.9	61.2		64.4	4.7
Level of Service	D	D	E		E	A
Approach Delay (s)	48.5		61.2			30.1
Approach LOS	D		E			C

Intersection Summary























HCM 2000 Control Delay	42.9	HCM 2000 Level of Service	D
HCM 2000 Volume to Capacity ratio	0.93		
Actuated Cycle Length (s)	94.4	Sum of lost time (s)	19.5
Intersection Capacity Utilization	84.1%	ICU Level of Service	E
Analysis Period (min)	15		
c Critical Lane Group			

**Appendix G:
Horizon Year 2040
Without Project
Synchro Worksheets**

This page intentionally left blank

HCM 2010 Signalized Intersection Summary
 1: Cayote Canyon Rd & Duncan Canyon Rd

Horizon (Yr 2040) AM
 02/25/2019

												
Movement	EBL	EBT	EBR	WBL	WBT	WBR	NBL	NBT	NBR	SBL	SBT	SBR
Lane Configurations												
Traffic Volume (veh/h)	9	479	13	41	201	224	7	4	135	641	6	15
Future Volume (veh/h)	9	479	13	41	201	224	7	4	135	641	6	15
Number	5	2	12	1	6	16	3	8	18	7	4	14
Initial Q (Qb), veh	0	0	0	0	0	0	0	0	0	0	0	0
Ped-Bike Adj(A_pbT)	1.00		1.00	1.00		1.00	1.00		1.00	1.00		1.00
Parking Bus, Adj	1.00	1.00	1.00	1.00	1.00	1.00	1.00	1.00	1.00	1.00	1.00	1.00
Adj Sat Flow, veh/h/ln	1900	1900	1900	1900	1900	1900	1900	1900	1900	1900	1900	1900
Adj Flow Rate, veh/h	9	504	14	43	212	236	7	4	142	675	6	16
Adj No. of Lanes	1	2	0	1	2	0	1	1	1	1	1	1
Peak Hour Factor	0.95	0.95	0.95	0.95	0.95	0.95	0.95	0.95	0.95	0.95	0.95	0.95
Percent Heavy Veh, %	0	0	0	0	0	0	0	0	0	0	0	0
Cap, veh/h	41	740	21	133	465	416	0	215	302	731	703	652
Arrive On Green	0.02	0.21	0.21	0.07	0.26	0.26	0.11	0.11	0.11	0.40	0.37	0.40
Sat Flow, veh/h	1810	3588	100	1810	1805	1615	0	1900	1615	1810	1900	1615
Grp Volume(v), veh/h	9	253	265	43	212	236	0	4	142	675	6	16
Grp Sat Flow(s),veh/h/ln	1810	1805	1882	1810	1805	1615	0	1900	1615	1810	1900	1615
Q Serve(g_s), s	0.4	11.5	11.5	2.0	8.7	11.2	0.0	0.2	6.9	31.4	0.2	0.5
Cycle Q Clear(g_c), s	0.4	11.5	11.5	2.0	8.7	11.2	0.0	0.2	6.9	31.4	0.2	0.5
Prop In Lane	1.00		0.05	1.00		1.00	0.00		1.00	1.00		1.00
Lane Grp Cap(c), veh/h	41	372	388	133	465	416	0	215	302	731	703	652
V/C Ratio(X)	0.22	0.68	0.68	0.32	0.46	0.57	0.00	0.02	0.47	0.92	0.01	0.02
Avail Cap(c_a), veh/h	204	561	585	204	561	502	0	494	539	1090	1080	973
HCM Platoon Ratio	1.00	1.00	1.00	1.00	1.00	1.00	1.00	1.00	1.00	1.00	1.00	1.00
Upstream Filter(I)	1.00	1.00	1.00	1.00	1.00	1.00	0.00	1.00	1.00	1.00	1.00	1.00
Uniform Delay (d), s/veh	42.5	32.4	32.4	38.9	27.6	28.6	0.0	34.9	32.1	25.1	17.6	15.9
Incr Delay (d2), s/veh	2.7	2.2	2.1	1.4	0.7	1.2	0.0	0.0	1.1	9.5	0.0	0.0
Initial Q Delay(d3),s/veh	0.0	0.0	0.0	0.0	0.0	0.0	0.0	0.0	0.0	0.0	0.0	0.0
%ile BackOfQ(50%),veh/ln	0.2	5.9	6.2	1.0	4.4	5.1	0.0	0.1	3.2	17.5	0.1	0.2
LnGrp Delay(d),s/veh	45.2	34.6	34.6	40.3	28.3	29.8	0.0	34.9	33.2	34.6	17.6	15.9
LnGrp LOS	D	C	C	D	C	C		C	C	C	B	B
Approach Vol, veh/h		527			491			146			697	
Approach Delay, s/veh		34.8			30.1			33.3			34.0	
Approach LOS		C			C			C			C	
Timer	1	2	3	4	5	6	7	8				
Assigned Phs	1	2		4	5	6		8				
Phs Duration (G+Y+Rc), s	11.0	22.7		40.2	6.5	27.3		14.5				
Change Period (Y+Rc), s	4.5	4.5		4.5	4.5	4.5		* 4.5				
Max Green Setting (Gmax), s	10.0	27.5		53.3	10.0	27.5		* 23				
Max Q Clear Time (g_c+I1), s	4.0	13.5		33.4	2.4	13.2		8.9				
Green Ext Time (p_c), s	0.0	4.7		2.3	0.0	4.8		0.3				
Intersection Summary												
HCM 2010 Ctrl Delay			33.1									
HCM 2010 LOS			C									
Notes												

Intersection

Int Delay, s/veh 10.9

Movement EBL EBR NBL NBT SBT SBR

Lane Configurations						
Traffic Vol, veh/h	6	244	112	535	1529	21
Future Vol, veh/h	6	244	112	535	1529	21
Conflicting Peds, #/hr	0	0	0	0	0	0
Sign Control	Stop	Stop	Free	Free	Free	Free
RT Channelized	-	None	-	None	-	None
Storage Length	0	-	120	-	-	-
Veh in Median Storage, #	0	-	-	0	0	-
Grade, %	0	-	-	0	0	-
Peak Hour Factor	95	95	95	95	95	95
Heavy Vehicles, %	0	0	0	0	0	0
Mvmt Flow	6	257	118	563	1609	22

Major/Minor Minor2 Major1 Major2

Conflicting Flow All	2138	816	1632	0	-	0
Stage 1	1621	-	-	-	-	-
Stage 2	517	-	-	-	-	-
Critical Hdwy	6.8	6.9	4.1	-	-	-
Critical Hdwy Stg 1	5.8	-	-	-	-	-
Critical Hdwy Stg 2	5.8	-	-	-	-	-
Follow-up Hdwy	3.5	3.3	2.2	-	-	-
Pot Cap-1 Maneuver	43	324	403	-	-	-
Stage 1	150	-	-	-	-	-
Stage 2	569	-	-	-	-	-
Platoon blocked, %				-	-	-
Mov Cap-1 Maneuver	30	324	403	-	-	-
Mov Cap-2 Maneuver	30	-	-	-	-	-
Stage 1	150	-	-	-	-	-
Stage 2	402	-	-	-	-	-

Approach EB NB SB



















HCM Control Delay, s	98.5	3	0
HCM LOS	F		

Minor Lane/Major Mvmt NBL NBT EBLn1 SBT SBR

Capacity (veh/h)	403	-	262	-	-
HCM Lane V/C Ratio	0.293	-	1.004	-	-
HCM Control Delay (s)	17.6	-	98.5	-	-
HCM Lane LOS	C	-	F	-	-
HCM 95th %tile Q(veh)	1.2	-	10	-	-

HCM 2010 Signalized Intersection Summary
7: Sierra Ave & I-15 SB Ramps

Horizon (Yr 2040) AM
05/16/2018

												
Movement	EBL	EBT	EBR	WBL	WBT	WBR	NBL	NBT	NBR	SBL	SBT	SBR
Lane Configurations												
Traffic Volume (veh/h)	0	0	0	1096	0	272	854	725	0	0	688	1124
Future Volume (veh/h)	0	0	0	1096	0	272	854	725	0	0	688	1124
Number				7	4	14	1	6	16	5	2	12
Initial Q (Qb), veh				0	0	0	0	0	0	0	0	0
Ped-Bike Adj(A_pbT)				1.00		1.00	1.00		1.00	1.00		1.00
Parking Bus, Adj				1.00	1.00	1.00	1.00	1.00	1.00	1.00	1.00	1.00
Adj Sat Flow, veh/h/ln				1900	1900	1900	1900	1900	0	0	1900	1900
Adj Flow Rate, veh/h				1154	0	286	899	763	0	0	724	1183
Adj No. of Lanes				2	1	0	1	2	0	0	2	1
Peak Hour Factor				0.95	0.95	0.95	0.95	0.95	0.95	0.95	0.95	0.95
Percent Heavy Veh, %				0	0	0	0	0	0	0	0	0
Cap, veh/h				1258	0	573	557	1996	0	0	747	334
Arrive On Green				0.35	0.00	0.35	0.51	0.92	0.00	0.00	0.21	0.21
Sat Flow, veh/h				3547	0	1615	1810	3705	0	0	3705	1615
Grp Volume(v), veh/h				1154	0	286	899	763	0	0	724	1183
Grp Sat Flow(s),veh/h/ln				1773	0	1615	1810	1805	0	0	1805	1615
Q Serve(g_s), s				40.5	0.0	18.1	40.0	3.2	0.0	0.0	25.9	26.9
Cycle Q Clear(g_c), s				40.5	0.0	18.1	40.0	3.2	0.0	0.0	25.9	26.9
Prop In Lane				1.00		1.00	1.00		0.00	0.00		1.00
Lane Grp Cap(c), veh/h				1258	0	573	557	1996	0	0	747	334
V/C Ratio(X)				0.92	0.00	0.50	1.61	0.38	0.00	0.00	0.97	3.54
Avail Cap(c_a), veh/h				1337	0	609	557	1996	0	0	747	334
HCM Platoon Ratio				1.00	1.00	1.00	1.67	1.67	1.00	1.00	1.00	1.00
Upstream Filter(I)				1.00	0.00	1.00	0.63	0.63	0.00	0.00	1.00	1.00
Uniform Delay (d), s/veh				40.1	0.0	32.9	31.6	2.3	0.0	0.0	51.1	51.6
Incr Delay (d2), s/veh				9.9	0.0	0.7	281.8	0.3	0.0	0.0	26.3	1151.0
Initial Q Delay(d3),s/veh				0.0	0.0	0.0	0.0	0.0	0.0	0.0	0.0	0.0
%ile BackOfQ(50%),veh/ln				21.4	0.0	8.1	63.2	1.5	0.0	0.0	15.6	118.8
LnGrp Delay(d),s/veh				50.0	0.0	33.6	313.4	2.7	0.0	0.0	77.4	1202.5
LnGrp LOS				D		C	F	A			E	F
Approach Vol, veh/h					1440			1662			1907	
Approach Delay, s/veh					46.7			170.8			775.4	
Approach LOS					D			F			F	
Timer	1	2	3	4	5	6	7	8				
Assigned Phs	1	2		4		6						
Phs Duration (G+Y+Rc), s	45.0	32.9		52.1		77.9						
Change Period (Y+Rc), s	5.0	6.0		6.0		6.0						
Max Green Setting (Gmax), s	40.0	24.0		49.0		69.0						
Max Q Clear Time (g_c+I1), s	42.0	28.9		42.5		5.2						
Green Ext Time (p_c), s	0.0	0.0		3.6		35.9						
Intersection Summary												
HCM 2010 Ctrl Delay				365.3								
HCM 2010 LOS				F								

HCM 2010 Signalized Intersection Summary
 8: Sierra Ave & I-15 NB Ramps

Horizon (Yr 2040) AM
 05/16/2018



Movement	EBL	EBT	EBR	WBL	WBT	WBR	NBL	NBT	NBR	SBL	SBT	SBR
Lane Configurations												
Traffic Volume (veh/h)	339	0	381	0	0	0	0	1240	1221	210	1574	0
Future Volume (veh/h)	339	0	381	0	0	0	0	1240	1221	210	1574	0
Number	3	8	18				1	6	16	5	2	12
Initial Q (Qb), veh	0	0	0				0	0	0	0	0	0
Ped-Bike Adj(A_pbT)	1.00		1.00				1.00	1.00	1.00			1.00
Parking Bus, Adj	1.00	1.00	1.00				1.00	1.00	1.00	1.00	1.00	1.00
Adj Sat Flow, veh/h/ln	1900	1900	1900				0	1900	1900	1900	1900	0
Adj Flow Rate, veh/h	489	0	260				0	1305	1285	221	1657	0
Adj No. of Lanes	2	0	1				0	2	1	1	2	0
Peak Hour Factor	0.95	0.95	0.95				0.95	0.95	0.95	0.95	0.95	0.95
Percent Heavy Veh, %	0	0	0				0	0	0	0	0	0
Cap, veh/h	684	0	305				0	1968	880	245	2594	0
Arrive On Green	0.19	0.00	0.19				0.00	0.55	0.55	0.27	1.00	0.00
Sat Flow, veh/h	3619	0	1615				0	3705	1615	1810	3705	0
Grp Volume(v), veh/h	489	0	260				0	1305	1285	221	1657	0
Grp Sat Flow(s),veh/h/ln	1810	0	1615				0	1805	1615	1810	1805	0
Q Serve(g_s), s	16.5	0.0	20.2				0.0	33.5	70.9	15.3	0.0	0.0
Cycle Q Clear(g_c), s	16.5	0.0	20.2				0.0	33.5	70.9	15.3	0.0	0.0
Prop In Lane	1.00		1.00				0.00		1.00	1.00		0.00
Lane Grp Cap(c), veh/h	684	0	305				0	1968	880	245	2594	0
V/C Ratio(X)	0.71	0.00	0.85				0.00	0.66	1.46	0.90	0.64	0.00
Avail Cap(c_a), veh/h	974	0	435				0	1968	880	404	2594	0
HCM Platoon Ratio	1.00	1.00	1.00				1.00	1.00	1.00	2.00	2.00	1.00
Upstream Filter(I)	1.00	0.00	1.00				0.00	0.34	0.34	0.18	0.18	0.00
Uniform Delay (d), s/veh	49.4	0.0	50.9				0.0	21.1	29.6	46.6	0.0	0.0
Incr Delay (d2), s/veh	1.4	0.0	10.8				0.0	0.6	209.1	2.0	0.2	0.0
Initial Q Delay(d3),s/veh	0.0	0.0	0.0				0.0	0.0	0.0	0.0	0.0	0.0
%ile BackOfQ(50%),veh/ln	8.4	0.0	9.9				0.0	16.8	82.4	7.7	0.1	0.0
LnGrp Delay(d),s/veh	50.9	0.0	61.7				0.0	21.7	238.7	48.6	0.2	0.0
LnGrp LOS	D		E					C	F	D	A	
Approach Vol, veh/h		749						2590			1878	
Approach Delay, s/veh		54.6						129.3			5.9	
Approach LOS		D						F			A	
Timer	1	2	3	4	5	6	7	8				
Assigned Phs		2			5	6		8				
Phs Duration (G+Y+Rc), s		99.4			22.6	76.9		30.6				
Change Period (Y+Rc), s		6.0			5.0	6.0		6.0				
Max Green Setting (Gmax), s		83.0			29.0	49.0		35.0				
Max Q Clear Time (g_c+I1), s		2.0			17.3	72.9		22.2				
Green Ext Time (p_c), s		74.6			0.2	0.0		2.3				
Intersection Summary												
HCM 2010 Ctrl Delay			74.2									
HCM 2010 LOS			E									
Notes												

HCM Signalized Intersection Capacity Analysis
 9: Sierra Ave & Riverside Ave

Horizon (Yr 2040) AM
 05/16/2018

























Movement	WBL	WBR	NBT	NBR	SBL	SBT
Lane Configurations	↵	↵↵	↕↕↕		↵↵	↕↕↕
Traffic Volume (vph)	63	859	1602	54	859	1096
Future Volume (vph)	63	859	1602	54	859	1096
Ideal Flow (vphpl)	1900	1900	1900	1900	1900	1900
Total Lost time (s)	6.5	6.5	8.0		7.0	8.0
Lane Util. Factor	1.00	0.88	0.91		0.97	0.91
Frt	1.00	0.85	1.00		1.00	1.00
Flt Protected	0.95	1.00	1.00		0.95	1.00
Satd. Flow (prot)	1805	2842	5162		3502	5187
Flt Permitted	0.95	1.00	1.00		0.95	1.00
Satd. Flow (perm)	1805	2842	5162		3502	5187
Peak-hour factor, PHF	0.95	0.95	0.95	0.95	0.95	0.95
Adj. Flow (vph)	66	904	1686	57	904	1154
RTOR Reduction (vph)	0	754	3	0	0	0
Lane Group Flow (vph)	66	150	1740	0	904	1154
Heavy Vehicles (%)	0%	0%	0%	0%	0%	0%
Turn Type	Perm	Perm	NA		Prot	NA
Protected Phases			6		5	2
Permitted Phases	4	4				
Actuated Green, G (s)	11.4	11.4	36.1		27.9	69.0
Effective Green, g (s)	9.4	9.4	34.1		25.9	67.0
Actuated g/C Ratio	0.10	0.10	0.38		0.28	0.74
Clearance Time (s)	4.5	4.5	6.0		5.0	6.0
Vehicle Extension (s)	3.0	3.0	3.0		3.0	3.0
Lane Grp Cap (vph)	186	293	1936		997	3823
v/s Ratio Prot			c0.34		c0.26	0.22
v/s Ratio Perm	0.04	c0.05				
v/c Ratio	0.35	0.51	0.90		0.91	0.30
Uniform Delay, d1	37.9	38.6	26.8		31.3	4.0
Progression Factor	1.00	1.00	1.00		1.00	1.00
Incremental Delay, d2	1.2	1.5	6.0		11.6	0.0
Delay (s)	39.1	40.1	32.8		42.9	4.1
Level of Service	D	D	C		D	A
Approach Delay (s)	40.0		32.8			21.1
Approach LOS	D		C			C

Intersection Summary			
HCM 2000 Control Delay	29.2	HCM 2000 Level of Service	C
HCM 2000 Volume to Capacity ratio	0.82		
Actuated Cycle Length (s)	90.9	Sum of lost time (s)	19.5
Intersection Capacity Utilization	78.7%	ICU Level of Service	D
Analysis Period (min)	15		
c Critical Lane Group			

HCM 2010 Signalized Intersection Summary
 1: Cayote Canyon Rd & Duncan Canyon Rd

Horizon (Yr 2040) PM
 02/27/2019

												
Movement	EBL	EBT	EBR	WBL	WBT	WBR	NBL	NBT	NBR	SBL	SBT	SBR
Lane Configurations												
Traffic Volume (veh/h)	22	312	15	179	431	693	13	1	110	440	0	6
Future Volume (veh/h)	22	312	15	179	431	693	13	1	110	440	0	6
Number	5	2	12	1	6	16	3	8	18	7	4	14
Initial Q (Qb), veh	0	0	0	0	0	0	0	0	0	0	0	0
Ped-Bike Adj(A_pbT)	1.00		1.00	1.00		1.00	1.00		1.00	1.00		1.00
Parking Bus, Adj	1.00	1.00	1.00	1.00	1.00	1.00	1.00	1.00	1.00	1.00	1.00	1.00
Adj Sat Flow, veh/h/ln	1900	1900	1900	1900	1900	1900	1900	1900	1900	1900	1900	1900
Adj Flow Rate, veh/h	23	328	16	188	454	729	14	1	116	463	0	6
Adj No. of Lanes	1	2	0	1	2	0	1	1	1	1	1	1
Peak Hour Factor	0.95	0.95	0.95	0.95	0.95	0.95	0.95	0.95	0.95	0.95	0.95	0.95
Percent Heavy Veh, %	0	0	0	0	0	0	0	0	0	0	0	0
Cap, veh/h	81	1303	63	220	810	724	0	159	331	492	517	439
Arrive On Green	0.04	0.37	0.37	0.12	0.45	0.45	0.08	0.08	0.08	0.27	0.00	0.27
Sat Flow, veh/h	1810	3505	170	1810	1805	1615	0	1900	1615	1810	1900	1615
Grp Volume(v), veh/h	23	168	176	188	454	729	0	1	116	463	0	6
Grp Sat Flow(s),veh/h/ln	1810	1805	1870	1810	1805	1615	0	1900	1615	1810	1900	1615
Q Serve(g_s), s	1.5	7.7	7.8	12.1	22.1	53.5	0.0	0.1	7.3	29.9	0.0	0.3
Cycle Q Clear(g_c), s	1.5	7.7	7.8	12.1	22.1	53.5	0.0	0.1	7.3	29.9	0.0	0.3
Prop In Lane	1.00		0.09	1.00		1.00	0.00		1.00	1.00		1.00
Lane Grp Cap(c), veh/h	81	671	695	220	810	724	0	159	331	492	517	439
V/C Ratio(X)	0.28	0.25	0.25	0.86	0.56	1.01	0.00	0.01	0.35	0.94	0.00	0.01
Avail Cap(c_a), veh/h	152	671	695	387	810	724	0	366	508	539	566	481
HCM Platoon Ratio	1.00	1.00	1.00	1.00	1.00	1.00	1.00	1.00	1.00	1.00	1.00	1.00
Upstream Filter(I)	1.00	1.00	1.00	1.00	1.00	1.00	0.00	1.00	1.00	1.00	0.00	1.00
Uniform Delay (d), s/veh	55.1	26.0	26.0	51.4	24.2	32.9	0.0	50.1	40.6	42.5	0.0	31.7
Incr Delay (d2), s/veh	1.9	0.2	0.2	9.2	0.9	35.0	0.0	0.0	0.6	23.9	0.0	0.0
Initial Q Delay(d3),s/veh	0.0	0.0	0.0	0.0	0.0	0.0	0.0	0.0	0.0	0.0	0.0	0.0
%ile BackOfQ(50%),veh/ln	0.8	3.9	4.0	6.6	11.2	30.8	0.0	0.0	3.3	18.2	0.0	0.1
LnGrp Delay(d),s/veh	57.0	26.1	26.2	60.6	25.1	67.9	0.0	50.1	41.2	66.4	0.0	31.7
LnGrp LOS	E	C	C	E	C	F		D	D	E		C
Approach Vol, veh/h		367			1371			117			469	
Approach Delay, s/veh		28.1			52.7			41.3			65.9	
Approach LOS		C			D			D			E	
Timer	1	2	3	4	5	6	7	8				
Assigned Phs	1	2		4	5	6		8				
Phs Duration (G+Y+Rc), s	19.0	48.9		36.9	9.8	58.0		14.5				
Change Period (Y+Rc), s	4.5	4.5		4.5	4.5	4.5		* 4.5				
Max Green Setting (Gmax), s	25.5	38.0		35.5	10.0	53.5		* 23				
Max Q Clear Time (g_c+I1), s	14.1	9.8		31.9	3.5	55.5		9.3				
Green Ext Time (p_c), s	0.4	1.9		0.6	0.0	0.0		0.2				
Intersection Summary												
HCM 2010 Ctrl Delay			50.9									
HCM 2010 LOS			D									
Notes												

Intersection						
Int Delay, s/veh	13.1					
Movement	EBL	EBR	NBL	NBT	SBT	SBR
Lane Configurations						
Traffic Vol, veh/h	22	206	298	1113	750	4
Future Vol, veh/h	22	206	298	1113	750	4
Conflicting Peds, #/hr	0	0	0	0	0	0
Sign Control	Stop	Stop	Free	Free	Free	Free
RT Channelized	-	None	-	None	-	None
Storage Length	0	-	120	-	-	-
Veh in Median Storage, #	0	-	-	0	0	-
Grade, %	0	-	-	0	0	-
Peak Hour Factor	95	95	95	95	95	95
Heavy Vehicles, %	0	0	0	0	0	0
Mvmt Flow	23	217	314	1172	789	4



















Major/Minor	Minor2	Major1		Major2	
Conflicting Flow All	2005	397	794	0	0
Stage 1	792	-	-	-	-
Stage 2	1213	-	-	-	-
Critical Hdwy	6.8	6.9	4.1	-	-
Critical Hdwy Stg 1	5.8	-	-	-	-
Critical Hdwy Stg 2	5.8	-	-	-	-
Follow-up Hdwy	3.5	3.3	2.2	-	-
Pot Cap-1 Maneuver	53	608	836	-	-
Stage 1	412	-	-	-	-
Stage 2	248	-	-	-	-
Platoon blocked, %				-	-
Mov Cap-1 Maneuver	33	608	836	-	-
Mov Cap-2 Maneuver	33	-	-	-	-
Stage 1	412	-	-	-	-
Stage 2	155	-	-	-	-

Approach	EB	NB	SB
HCM Control Delay, s	121.6	2.5	0
HCM LOS	F		

Minor Lane/Major Mvmt	NBL	NBT	EBLn1	SBT	SBR
Capacity (veh/h)	836	-	227	-	-
HCM Lane V/C Ratio	0.375	-	1.057	-	-
HCM Control Delay (s)	11.9	-	121.6	-	-
HCM Lane LOS	B	-	F	-	-
HCM 95th %tile Q(veh)	1.8	-	10.3	-	-

HCM 2010 Signalized Intersection Summary
 7: Sierra Ave & I-15 SB Ramps

Horizon (Yr 2040) PM
 05/16/2018

												
Movement	EBL	EBT	EBR	WBL	WBT	WBR	NBL	NBT	NBR	SBL	SBT	SBR
Lane Configurations												
Traffic Volume (veh/h)	0	0	0	1135	6	251	398	1526	0	0	701	513
Future Volume (veh/h)	0	0	0	1135	6	251	398	1526	0	0	701	513
Number				7	4	14	1	6	16	5	2	12
Initial Q (Qb), veh				0	0	0	0	0	0	0	0	0
Ped-Bike Adj(A_pbT)				1.00		1.00	1.00		1.00	1.00		1.00
Parking Bus, Adj				1.00	1.00	1.00	1.00	1.00	1.00	1.00	1.00	1.00
Adj Sat Flow, veh/h/ln				1900	1900	1900	1900	1900	0	0	1900	1900
Adj Flow Rate, veh/h				1195	6	264	419	1606	0	0	738	540
Adj No. of Lanes				2	1	0	1	2	0	0	2	1
Peak Hour Factor				0.95	0.95	0.95	0.95	0.95	0.95	0.95	0.95	0.95
Percent Heavy Veh, %				0	0	0	0	0	0	0	0	0
Cap, veh/h				1348	14	608	348	1891	0	0	1058	473
Arrive On Green				0.38	0.38	0.38	0.38	1.00	0.00	0.00	0.29	0.29
Sat Flow, veh/h				3510	36	1584	1810	3705	0	0	3705	1615
Grp Volume(v), veh/h				1195	0	270	419	1606	0	0	738	540
Grp Sat Flow(s),veh/h/ln				1755	0	1620	1810	1805	0	0	1805	1615
Q Serve(g_s), s				41.3	0.0	16.0	25.0	0.0	0.0	0.0	23.6	38.1
Cycle Q Clear(g_c), s				41.3	0.0	16.0	25.0	0.0	0.0	0.0	23.6	38.1
Prop In Lane				1.00		0.98	1.00		0.00	0.00		1.00
Lane Grp Cap(c), veh/h				1348	0	622	348	1891	0	0	1058	473
V/C Ratio(X)				0.89	0.00	0.43	1.20	0.85	0.00	0.00	0.70	1.14
Avail Cap(c_a), veh/h				1620	0	748	348	1891	0	0	1058	473
HCM Platoon Ratio				1.00	1.00	1.00	2.00	2.00	1.00	1.00	1.00	1.00
Upstream Filter(I)				1.00	0.00	1.00	0.09	0.09	0.00	0.00	1.00	1.00
Uniform Delay (d), s/veh				37.4	0.0	29.6	40.0	0.0	0.0	0.0	40.8	46.0
Incr Delay (d2), s/veh				5.5	0.0	0.5	94.5	0.5	0.0	0.0	3.8	86.2
Initial Q Delay(d3),s/veh				0.0	0.0	0.0	0.0	0.0	0.0	0.0	0.0	0.0
%ile BackOfQ(50%),veh/ln				21.0	0.0	7.2	21.5	0.1	0.0	0.0	12.3	28.3
LnGrp Delay(d),s/veh				43.0	0.0	30.1	134.5	0.5	0.0	0.0	44.7	132.1
LnGrp LOS				D		C	F	A			D	F
Approach Vol, veh/h					1465			2025			1278	
Approach Delay, s/veh					40.6			28.2			81.6	
Approach LOS					D			C			F	
Timer	1	2	3	4	5	6	7	8				
Assigned Phs	1	2		4		6						
Phs Duration (G+Y+Rc), s	30.0	44.1		55.9		74.1						
Change Period (Y+Rc), s	5.0	6.0		6.0		6.0						
Max Green Setting (Gmax), s	25.0	28.0		60.0		58.0						
Max Q Clear Time (g_c+I1), s	27.0	40.1		43.3		2.0						
Green Ext Time (p_c), s	0.0	0.0		6.6		39.6						
Intersection Summary												
HCM 2010 Ctrl Delay				46.3								
HCM 2010 LOS				D								

HCM 2010 Signalized Intersection Summary
 8: Sierra Ave & I-15 NB Ramps

Horizon (Yr 2040) PM
 05/16/2018



Movement	EBL	EBT	EBR	WBL	WBT	WBR	NBL	NBT	NBR	SBL	SBT	SBR
Lane Configurations												
Traffic Volume (veh/h)	897	0	782	0	0	0	0	1027	1686	306	1530	0
Future Volume (veh/h)	897	0	782	0	0	0	0	1027	1686	306	1530	0
Number	3	8	18				1	6	16	5	2	12
Initial Q (Qb), veh	0	0	0				0	0	0	0	0	0
Ped-Bike Adj(A_pbT)	1.00		1.00				1.00		1.00	1.00		1.00
Parking Bus, Adj	1.00	1.00	1.00				1.00	1.00	1.00	1.00	1.00	1.00
Adj Sat Flow, veh/h/ln	1900	1900	1900				0	1900	1900	1900	1900	0
Adj Flow Rate, veh/h	1200	0	549				0	1081	1775	322	1611	0
Adj No. of Lanes	2	0	1				0	2	1	1	2	0
Peak Hour Factor	0.95	0.95	0.95				0.95	0.95	0.95	0.95	0.95	0.95
Percent Heavy Veh, %	0	0	0				0	0	0	0	0	0
Cap, veh/h	1385	0	618				0	1075	481	342	1895	0
Arrive On Green	0.38	0.00	0.38				0.00	0.30	0.30	0.38	1.00	0.00
Sat Flow, veh/h	3619	0	1615				0	3705	1615	1810	3705	0
Grp Volume(v), veh/h	1200	0	549				0	1081	1775	322	1611	0
Grp Sat Flow(s),veh/h/ln	1810	0	1615				0	1805	1615	1810	1805	0
Q Serve(g_s), s	39.8	0.0	41.3				0.0	38.7	38.7	22.4	0.0	0.0
Cycle Q Clear(g_c), s	39.8	0.0	41.3				0.0	38.7	38.7	22.4	0.0	0.0
Prop In Lane	1.00		1.00				0.00		1.00	1.00		0.00
Lane Grp Cap(c), veh/h	1385	0	618				0	1075	481	342	1895	0
V/C Ratio(X)	0.87	0.00	0.89				0.00	1.01	3.69	0.94	0.85	0.00
Avail Cap(c_a), veh/h	1587	0	708				0	1075	481	390	1895	0
HCM Platoon Ratio	1.00	1.00	1.00				1.00	1.00	1.00	2.00	2.00	1.00
Upstream Filter(I)	1.00	0.00	1.00				0.00	0.17	0.17	0.40	0.40	0.00
Uniform Delay (d), s/veh	37.1	0.0	37.5				0.0	45.7	45.7	39.8	0.0	0.0
Incr Delay (d2), s/veh	4.8	0.0	12.1				0.0	12.7	12.4	14.8	2.1	0.0
Initial Q Delay(d3),s/veh	0.0	0.0	0.0				0.0	0.0	0.0	0.0	0.0	0.0
%ile BackOfQ(50%),veh/ln	20.8	0.0	20.5				0.0	21.1	179.1	12.5	0.5	0.0
LnGrp Delay(d),s/veh	41.9	0.0	49.6				0.0	58.4	1258.1	54.6	2.1	0.0
LnGrp LOS	D		D					F	F	D	A	
Approach Vol, veh/h		1749						2856			1933	
Approach Delay, s/veh		44.3						804.0			10.8	
Approach LOS		D						F			B	
Timer	1	2	3	4	5	6	7	8				
Assigned Phs		2			5	6		8				
Phs Duration (G+Y+Rc), s		74.2			29.5	44.7		55.8				
Change Period (Y+Rc), s		6.0			5.0	6.0		6.0				
Max Green Setting (Gmax), s		61.0			28.0	28.0		57.0				
Max Q Clear Time (g_c+I1), s		2.0			24.4	40.7		43.3				
Green Ext Time (p_c), s		58.0			0.2	0.0		6.4				
Intersection Summary												
HCM 2010 Ctrl Delay			366.3									
HCM 2010 LOS			F									
Notes												

HCM Signalized Intersection Capacity Analysis
9: Sierra Ave & Riverside Ave

Horizon (Yr 2040) PM
05/16/2018



Movement	WBL	WBR	NBT	NBR	SBL	SBT
Lane Configurations	↶	↶↶	↶↶↶		↶↶	↶↶↶
Traffic Volume (vph)	31	1112	1601	29	801	1511
Future Volume (vph)	31	1112	1601	29	801	1511
Ideal Flow (vphpl)	1900	1900	1900	1900	1900	1900
Total Lost time (s)	6.5	6.5	8.0		7.0	8.0
Lane Util. Factor	1.00	0.88	0.91		0.97	0.91
Frt	1.00	0.85	1.00		1.00	1.00
Flt Protected	0.95	1.00	1.00		0.95	1.00
Satd. Flow (prot)	1805	2842	5173		3502	5187
Flt Permitted	0.95	1.00	1.00		0.95	1.00
Satd. Flow (perm)	1805	2842	5173		3502	5187
Peak-hour factor, PHF	0.95	0.95	0.95	0.95	0.95	0.95
Adj. Flow (vph)	33	1171	1685	31	843	1591
RTOR Reduction (vph)	0	649	2	0	0	0
Lane Group Flow (vph)	33	522	1714	0	843	1591
Heavy Vehicles (%)	0%	0%	0%	0%	0%	0%
Turn Type	Perm	Perm	NA		Prot	NA
Protected Phases			6		5	2
Permitted Phases	4	4				
Actuated Green, G (s)	21.2	21.2	36.0		26.0	67.0
Effective Green, g (s)	19.2	19.2	34.0		24.0	65.0
Actuated g/C Ratio	0.19	0.19	0.34		0.24	0.66
Clearance Time (s)	4.5	4.5	6.0		5.0	6.0
Vehicle Extension (s)	3.0	3.0	3.0		3.0	3.0
Lane Grp Cap (vph)	351	552	1781		851	3415
v/s Ratio Prot			c0.33		c0.24	0.31
v/s Ratio Perm	0.02	c0.18				
v/c Ratio	0.09	0.95	0.96		0.99	0.47
Uniform Delay, d1	32.6	39.2	31.7		37.2	8.3
Progression Factor	1.00	1.00	1.00		1.00	1.00
Incremental Delay, d2	0.1	25.2	13.5		28.4	0.1
Delay (s)	32.7	64.4	45.2		65.7	8.4
Level of Service	C	E	D		E	A
Approach Delay (s)	63.5		45.2			28.2
Approach LOS	E		D			C

Intersection Summary























HCM 2000 Control Delay	41.6	HCM 2000 Level of Service	D
HCM 2000 Volume to Capacity ratio	0.94		
Actuated Cycle Length (s)	98.7	Sum of lost time (s)	19.5
Intersection Capacity Utilization	82.6%	ICU Level of Service	E
Analysis Period (min)	15		
c Critical Lane Group			

**Appendix H:
Horizon Year 2040
With Project
Synchro Worksheets**

This page intentionally left blank

HCM 2010 Signalized Intersection Summary
 1: Coyote Canyon Rd & Duncan Canyon Rd

Horizon (Yr 2040) W/ Project AM
 02/25/2019

												
Movement	EBL	EBT	EBR	WBL	WBT	WBR	NBL	NBT	NBR	SBL	SBT	SBR
Lane Configurations												
Traffic Volume (veh/h)	9	479	13	41	201	243	7	4	135	647	6	15
Future Volume (veh/h)	9	479	13	41	201	243	7	4	135	647	6	15
Number	5	2	12	1	6	16	3	8	18	7	4	14
Initial Q (Qb), veh	0	0	0	0	0	0	0	0	0	0	0	0
Ped-Bike Adj(A_pbT)	1.00		1.00	1.00		1.00	1.00		1.00	1.00		1.00
Parking Bus, Adj	1.00	1.00	1.00	1.00	1.00	1.00	1.00	1.00	1.00	1.00	1.00	1.00
Adj Sat Flow, veh/h/ln	1900	1900	1900	1900	1900	1900	1900	1900	1900	1900	1900	1900
Adj Flow Rate, veh/h	9	504	14	43	212	256	7	4	142	681	6	16
Adj No. of Lanes	1	2	0	1	2	0	1	1	1	1	1	1
Peak Hour Factor	0.95	0.95	0.95	0.95	0.95	0.95	0.95	0.95	0.95	0.95	0.95	0.95
Percent Heavy Veh, %	0	0	0	0	0	0	0	0	0	0	0	0
Cap, veh/h	41	717	20	134	454	406	0	217	304	736	773	657
Arrive On Green	0.02	0.20	0.20	0.07	0.25	0.25	0.11	0.11	0.11	0.41	0.41	0.41
Sat Flow, veh/h	1810	3588	100	1810	1805	1615	0	1900	1615	1810	1900	1615
Grp Volume(v), veh/h	9	253	265	43	212	256	0	4	142	681	6	16
Grp Sat Flow(s),veh/h/ln	1810	1805	1882	1810	1805	1615	0	1900	1615	1810	1900	1615
Q Serve(g_s), s	0.4	11.5	11.5	2.0	8.7	12.4	0.0	0.2	6.9	31.4	0.2	0.5
Cycle Q Clear(g_c), s	0.4	11.5	11.5	2.0	8.7	12.4	0.0	0.2	6.9	31.4	0.2	0.5
Prop In Lane	1.00		0.05	1.00		1.00	0.00		1.00	1.00		1.00
Lane Grp Cap(c), veh/h	41	361	376	134	454	406	0	217	304	736	773	657
V/C Ratio(X)	0.22	0.70	0.70	0.32	0.47	0.63	0.00	0.02	0.47	0.93	0.01	0.02
Avail Cap(c_a), veh/h	206	484	505	206	484	433	0	499	543	1042	1095	930
HCM Platoon Ratio	1.00	1.00	1.00	1.00	1.00	1.00	1.00	1.00	1.00	1.00	1.00	1.00
Upstream Filter(I)	1.00	1.00	1.00	1.00	1.00	1.00	0.00	1.00	1.00	1.00	1.00	1.00
Uniform Delay (d), s/veh	42.1	32.7	32.7	38.5	27.8	29.2	0.0	34.5	31.7	24.7	15.5	15.6
Incr Delay (d2), s/veh	2.7	2.9	2.8	1.4	0.7	2.7	0.0	0.0	1.1	10.5	0.0	0.0
Initial Q Delay(d3),s/veh	0.0	0.0	0.0	0.0	0.0	0.0	0.0	0.0	0.0	0.0	0.0	0.0
%ile BackOfQ(50%),veh/ln	0.2	6.0	6.3	1.0	4.5	5.8	0.0	0.1	3.1	17.7	0.1	0.2
LnGrp Delay(d),s/veh	44.8	35.6	35.5	39.9	28.6	31.9	0.0	34.5	32.8	35.2	15.5	15.6
LnGrp LOS	D	D	D	D	C	C		C	C	D	B	B
Approach Vol, veh/h		527			511			146			703	
Approach Delay, s/veh		35.7			31.2			32.8			34.6	
Approach LOS		D			C			C			C	
Timer	1	2	3	4	5	6	7	8				
Assigned Phs	1	2		4	5	6		8				
Phs Duration (G+Y+Rc), s	11.0	22.0		40.2	6.5	26.5		14.5				
Change Period (Y+Rc), s	4.5	4.5		4.5	4.5	4.5		* 4.5				
Max Green Setting (Gmax), s	10.0	23.5		50.5	10.0	23.5		* 23				
Max Q Clear Time (g_c+I1), s	4.0	13.5		33.4	2.4	14.4		8.9				
Green Ext Time (p_c), s	0.0	4.0		2.3	0.0	3.8		0.3				
Intersection Summary												
HCM 2010 Ctrl Delay			33.9									
HCM 2010 LOS			C									
Notes												

Intersection						
Int Delay, s/veh	1.9					
Movement	EBT	EBR	WBL	WBT	NBL	NBR
Lane Configurations						
Traffic Vol, veh/h	251	28	75	109	9	22
Future Vol, veh/h	251	28	75	109	9	22
Conflicting Peds, #/hr	0	0	0	0	0	0
Sign Control	Free	Free	Free	Free	Stop	Stop
RT Channelized	-	None	-	None	-	None
Storage Length	-	-	-	-	0	-
Veh in Median Storage, #	0	-	-	0	0	-
Grade, %	0	-	-	0	0	-
Peak Hour Factor	95	95	95	95	95	95
Heavy Vehicles, %	0	0	0	0	0	0
Mvmt Flow	264	29	79	115	9	23

Major/Minor	Major1	Major2	Minor1		
Conflicting Flow All	0	0	294	0	552
Stage 1	-	-	-	-	279
Stage 2	-	-	-	-	273
Critical Hdwy	-	-	4.1	-	6.4
Critical Hdwy Stg 1	-	-	-	-	5.4
Critical Hdwy Stg 2	-	-	-	-	5.4
Follow-up Hdwy	-	-	2.2	-	3.5
Pot Cap-1 Maneuver	-	-	1279	-	498
Stage 1	-	-	-	-	773
Stage 2	-	-	-	-	778
Platoon blocked, %	-	-	-	-	-
Mov Cap-1 Maneuver	-	-	1279	-	465
Mov Cap-2 Maneuver	-	-	-	-	465
Stage 1	-	-	-	-	773
Stage 2	-	-	-	-	727

Approach	EB	WB	NB
HCM Control Delay, s	0	3.3	10.9
HCM LOS			B

Minor Lane/Major Mvmt	NBLn1	EBT	EBR	WBL	WBT
Capacity (veh/h)	644	-	-	1279	-
HCM Lane V/C Ratio	0.051	-	-	0.062	-
HCM Control Delay (s)	10.9	-	-	8	0
HCM Lane LOS	B	-	-	A	A
HCM 95th %tile Q(veh)	0.2	-	-	0.2	-

Intersection

Int Delay, s/veh 5.5

Movement	EBL	EBT	WBT	WBR	SBL	SBR
Lane Configurations		↕	↕		↕	
Traffic Vol, veh/h	0	97	262	160	251	0
Future Vol, veh/h	0	97	262	160	251	0
Conflicting Peds, #/hr	0	0	0	0	0	0
Sign Control	Free	Free	Free	Free	Stop	Stop
RT Channelized	-	None	-	None	-	None
Storage Length	-	-	-	-	0	-
Veh in Median Storage, #	-	0	0	-	0	-
Grade, %	-	0	0	-	0	-
Peak Hour Factor	95	95	95	95	95	95
Heavy Vehicles, %	0	0	0	0	0	0
Mvmt Flow	0	102	276	168	264	0

Major/Minor	Major1	Major2	Minor2
Conflicting Flow All	444	0	0
Stage 1	-	-	360
Stage 2	-	-	102
Critical Hdwy	4.1	-	6.4
Critical Hdwy Stg 1	-	-	5.4
Critical Hdwy Stg 2	-	-	5.4
Follow-up Hdwy	2.2	-	3.5
Pot Cap-1 Maneuver	1127	-	562
Stage 1	-	-	710
Stage 2	-	-	927
Platoon blocked, %	-	-	-
Mov Cap-1 Maneuver	1127	-	562
Mov Cap-2 Maneuver	-	-	562
Stage 1	-	-	710
Stage 2	-	-	927

Approach	EB	WB	SB
HCM Control Delay, s	0	0	17
HCM LOS			C

Minor Lane/Major Mvmt	EBL	EBT	WBT	WBR	SBLn1
Capacity (veh/h)	1127	-	-	-	562
HCM Lane V/C Ratio	-	-	-	-	0.47
HCM Control Delay (s)	0	-	-	-	17
HCM Lane LOS	A	-	-	-	C
HCM 95th %tile Q(veh)	0	-	-	-	2.5

HCM 2010 Signalized Intersection Summary
6: Sierra Ave & Lytle Creek Rd (W/ Realignment)

Horizon (Yr 2040) W/ Project AM
02/25/2019



Movement	EBL	EBR	NBL	NBT	SBT	SBR		
Lane Configurations								
Traffic Volume (veh/h)	3	328	394	543	1168	28		
Future Volume (veh/h)	3	328	394	543	1168	28		
Number	3	18	1	6	2	12		
Initial Q (Qb), veh	0	0	0	0	0	0		
Ped-Bike Adj(A_pbT)	1.00	1.00	1.00			1.00		
Parking Bus, Adj	1.00	1.00	1.00	1.00	1.00	1.00		
Adj Sat Flow, veh/h/ln	1900	1900	1900	1900	1900	1900		
Adj Flow Rate, veh/h	3	345	415	572	1229	29		
Adj No. of Lanes	0	0	1	2	2	0		
Peak Hour Factor	0.95	0.95	0.95	0.95	0.95	0.95		
Percent Heavy Veh, %	0	0	0	0	0	0		
Cap, veh/h	3	354	433	2315	1430	34		
Arrive On Green	0.22	0.24	0.18	0.64	0.40	0.42		
Sat Flow, veh/h	14	1599	1810	3705	3700	85		
Grp Volume(v), veh/h	349	0	415	572	615	643		
Grp Sat Flow(s),veh/h/ln	1617	0	1810	1805	1805	1885		
Q Serve(g_s), s	20.3	0.0	15.5	6.4	29.6	29.6		
Cycle Q Clear(g_c), s	20.3	0.0	15.5	6.4	29.6	29.6		
Prop In Lane	0.01	0.99	1.00			0.05		
Lane Grp Cap(c), veh/h	359	0	433	2315	716	748		
V/C Ratio(X)	0.97	0.00	0.96	0.25	0.86	0.86		
Avail Cap(c_a), veh/h	468	0	733	3023	770	804		
HCM Platoon Ratio	1.00	1.00	1.00	1.00	1.00	1.00		
Upstream Filter(I)	1.00	0.00	1.00	1.00	1.00	1.00		
Uniform Delay (d), s/veh	35.7	0.0	25.6	7.3	26.2	26.2		
Incr Delay (d2), s/veh	30.8	0.0	16.5	0.1	9.2	8.9		
Initial Q Delay(d3),s/veh	0.0	0.0	0.0	0.0	0.0	0.0		
%ile BackOfQ(50%),veh/ln	12.1	0.0	12.7	3.2	16.5	17.2		
LnGrp Delay(d),s/veh	66.5	0.0	42.0	7.3	35.4	35.1		
LnGrp LOS	E		D	A	D	D		
Approach Vol, veh/h	349			987	1258			
Approach Delay, s/veh	66.5			21.9	35.2			
Approach LOS	E			C	D			
Timer	1	2	3	4	5	6	7	8
Assigned Phs	1	2				6		8
Phs Duration (G+Y+Rc), s	23.2	44.1				67.4		27.5
Change Period (Y+Rc), s	4.5	4.5				4.5		4.5
Max Green Setting (Gmax), s	34.5	42.5				81.5		29.5
Max Q Clear Time (g_c+11), s	17.5	31.6				8.4		22.3
Green Ext Time (p_c), s	1.2	8.0				22.5		0.7
Intersection Summary								
HCM 2010 Ctrl Delay			34.4					
HCM 2010 LOS			C					
Notes								

HCM 2010 Signalized Intersection Summary
 7: Sierra Ave & I-15 SB Ramps

Horizon (Yr 2040) W/ Project AM
 05/16/2018



Movement	EBL	EBT	EBR	WBL	WBT	WBR	NBL	NBT	NBR	SBL	SBT	SBR
Lane Configurations				↖ ↗	↖		↖	↖ ↗			↖ ↗	↖
Traffic Volume (veh/h)	0	0	0	1096	0	348	854	857	0	0	723	1154
Future Volume (veh/h)	0	0	0	1096	0	348	854	857	0	0	723	1154
Number				7	4	14	1	6	16	5	2	12
Initial Q (Qb), veh				0	0	0	0	0	0	0	0	0
Ped-Bike Adj(A_pbT)				1.00		1.00	1.00		1.00	1.00		1.00
Parking Bus, Adj				1.00	1.00	1.00	1.00	1.00	1.00	1.00	1.00	1.00
Adj Sat Flow, veh/h/ln				1900	1900	1900	1900	1900	0	0	1900	1900
Adj Flow Rate, veh/h				1154	0	366	899	902	0	0	761	1215
Adj No. of Lanes				2	1	0	1	2	0	0	2	1
Peak Hour Factor				0.95	0.95	0.95	0.95	0.95	0.95	0.95	0.95	0.95
Percent Heavy Veh, %				0	0	0	0	0	0	0	0	0
Cap, veh/h				1173	0	534	626	2083	0	0	694	311
Arrive On Green				0.33	0.00	0.33	0.69	1.00	0.00	0.00	0.19	0.19
Sat Flow, veh/h				3547	0	1615	1810	3705	0	0	3705	1615
Grp Volume(v), veh/h				1154	0	366	899	902	0	0	761	1215
Grp Sat Flow(s),veh/h/ln				1773	0	1615	1810	1805	0	0	1805	1615
Q Serve(g_s), s				42.0	0.0	25.5	45.0	0.0	0.0	0.0	25.0	25.0
Cycle Q Clear(g_c), s				42.0	0.0	25.5	45.0	0.0	0.0	0.0	25.0	25.0
Prop In Lane				1.00		1.00	1.00		0.00	0.00		1.00
Lane Grp Cap(c), veh/h				1173	0	534	626	2083	0	0	694	311
V/C Ratio(X)				0.98	0.00	0.69	1.44	0.43	0.00	0.00	1.10	3.91
Avail Cap(c_a), veh/h				1173	0	534	626	2083	0	0	694	311
HCM Platoon Ratio				1.00	1.00	1.00	2.00	2.00	1.00	1.00	1.00	1.00
Upstream Filter(I)				1.00	0.00	1.00	0.53	0.53	0.00	0.00	0.43	0.43
Uniform Delay (d), s/veh				43.2	0.0	37.6	20.0	0.0	0.0	0.0	52.5	52.5
Incr Delay (d2), s/veh				22.3	0.0	3.6	200.7	0.3	0.0	0.0	53.6	1313.8
Initial Q Delay(d3),s/veh				0.0	0.0	0.0	0.0	0.0	0.0	0.0	0.0	0.0
%ile BackOfQ(50%),veh/ln				24.2	0.0	11.9	56.5	0.1	0.0	0.0	17.6	124.5
LnGrp Delay(d),s/veh				65.5	0.0	41.3	220.7	0.3	0.0	0.0	106.1	1366.3
LnGrp LOS				E		D	F	A			F	F
Approach Vol, veh/h						1520		1801			1976	
Approach Delay, s/veh						59.6		110.4			880.9	
Approach LOS						E		F			F	
Timer	1	2	3	4	5	6	7	8				
Assigned Phs	1	2		4		6						
Phs Duration (G+Y+Rc), s	50.0	31.0		49.0		81.0						
Change Period (Y+Rc), s	5.0	6.0		6.0		6.0						
Max Green Setting (Gmax), s	45.0	25.0		43.0		75.0						
Max Q Clear Time (g_c+M), s	47.0	27.0		44.0		2.0						
Green Ext Time (p_c), s	0.0	0.0		0.0		44.2						
Intersection Summary												
HCM 2010 Ctrl Delay				383.3								
HCM 2010 LOS				F								

HCM 2010 Signalized Intersection Summary
 8: Sierra Ave & I-15 NB Ramps

Horizon (Yr 2040) W/ Project AM

05/16/2018



Movement	EBL	EBT	EBR	WBL	WBT	WBR	NBL	NBT	NBR	SBL	SBT	SBR
Lane Configurations												
Traffic Volume (veh/h)	434	0	381	0	0	0	0	1277	1221	234	1585	0
Future Volume (veh/h)	434	0	381	0	0	0	0	1277	1221	234	1585	0
Number	3	8	18				1	6	16	5	2	12
Initial Q (Qb), veh	0	0	0				0	0	0	0	0	0
Ped-Bike Adj(A_pbT)	1.00		1.00				1.00		1.00	1.00		1.00
Parking Bus, Adj	1.00	1.00	1.00				1.00	1.00	1.00	1.00	1.00	1.00
Adj Sat Flow, veh/h/ln	1900	1900	1900				0	1900	1900	1900	1900	0
Adj Flow Rate, veh/h	582	0	267				0	1344	1285	246	1668	0
Adj No. of Lanes	2	0	1				0	2	1	1	2	0
Peak Hour Factor	0.95	0.95	0.95				0.95	0.95	0.95	0.95	0.95	0.95
Percent Heavy Veh, %	0	0	0				0	0	0	0	0	0
Cap, veh/h	709	0	316				0	1894	847	269	2570	0
Arrive On Green	0.20	0.00	0.20				0.00	0.52	0.52	0.30	1.00	0.00
Sat Flow, veh/h	3619	0	1615				0	3705	1615	1810	3705	0
Grp Volume(v), veh/h	582	0	267				0	1344	1285	246	1668	0
Grp Sat Flow(s),veh/h/ln	1810	0	1615				0	1805	1615	1810	1805	0
Q Serve(g_s), s	20.0	0.0	20.7				0.0	36.6	68.2	17.1	0.0	0.0
Cycle Q Clear(g_c), s	20.0	0.0	20.7				0.0	36.6	68.2	17.1	0.0	0.0
Prop In Lane	1.00		1.00				0.00		1.00	1.00		0.00
Lane Grp Cap(c), veh/h	709	0	316				0	1894	847	269	2570	0
V/C Ratio(X)	0.82	0.00	0.84				0.00	0.71	1.52	0.91	0.65	0.00
Avail Cap(c_a), veh/h	1002	0	447				0	1894	847	418	2570	0
HCM Platoon Ratio	1.00	1.00	1.00				1.00	1.00	1.00	2.00	2.00	1.00
Upstream Filter(l)	1.00	0.00	1.00				0.00	0.33	0.33	0.09	0.09	0.00
Uniform Delay (d), s/veh	50.1	0.0	50.4				0.0	23.4	30.9	44.9	0.0	0.0
Incr Delay (d2), s/veh	3.8	0.0	9.9				0.0	0.8	234.4	1.5	0.1	0.0
Initial Q Delay(d3),s/veh	0.0	0.0	0.0				0.0	0.0	0.0	0.0	0.0	0.0
%ile BackOfQ(50%),veh/ln	10.4	0.0	10.1				0.0	18.3	85.3	8.6	0.0	0.0
LnGrp Delay(d),s/veh	53.9	0.0	60.3				0.0	24.2	265.3	46.4	0.1	0.0
LnGrp LOS	D		E					C	F	D	A	
Approach Vol, veh/h		849						2629			1914	
Approach Delay, s/veh		55.9						142.0			6.1	
Approach LOS		E						F			A	
Timer	1	2	3	4	5	6	7	8				
Assigned Phs		2			5	6		8				
Phs Duration (G+Y+Rc), s		98.5			24.3	74.2		31.5				
Change Period (Y+Rc), s		6.0			5.0	6.0		6.0				
Max Green Setting (Gmax), s		82.0			30.0	47.0		36.0				
Max Q Clear Time (g_c+1), s		2.0			19.1	70.2		22.7				
Green Ext Time (p_c), s		74.2			0.3	0.0		2.8				
Intersection Summary												
HCM 2010 Ctrl Delay			80.2									
HCM 2010 LOS			F									
Notes												

HCM Signalized Intersection Capacity Analysis
9: Sierra Ave & Riverside Ave

Horizon (Yr 2040) W/ Project AM
05/16/2018

























Movement	WBL	WBR	NBT	NBR	SBL	SBT
Lane Configurations	↶	↶↶	↶↶↶		↶↶	↶↶↶
Traffic Volume (vph)	63	883	1615	54	866	1100
Future Volume (vph)	63	883	1615	54	866	1100
Ideal Flow (vphpl)	1900	1900	1900	1900	1900	1900
Total Lost time (s)	6.5	6.5	8.0		7.0	8.0
Lane Util. Factor	1.00	0.88	0.91		0.97	0.91
Frt	1.00	0.85	1.00		1.00	1.00
Flt Protected	0.95	1.00	1.00		0.95	1.00
Satd. Flow (prot)	1805	2842	5162		3502	5187
Flt Permitted	0.95	1.00	1.00		0.95	1.00
Satd. Flow (perm)	1805	2842	5162		3502	5187
Peak-hour factor, PHF	0.95	0.95	0.95	0.95	0.95	0.95
Adj. Flow (vph)	66	929	1700	57	912	1158
RTOR Reduction (vph)	0	770	3	0	0	0
Lane Group Flow (vph)	66	159	1754	0	912	1158
Heavy Vehicles (%)	0%	0%	0%	0%	0%	0%
Turn Type	Perm	Perm	NA		Prot	NA
Protected Phases			6		5	2
Permitted Phases	4	4				
Actuated Green, G (s)	11.2	11.2	36.8		28.1	69.9
Effective Green, g (s)	9.2	9.2	34.8		26.1	67.9
Actuated g/C Ratio	0.10	0.10	0.38		0.28	0.74
Clearance Time (s)	4.5	4.5	6.0		5.0	6.0
Vehicle Extension (s)	3.0	3.0	3.0		3.0	3.0
Lane Grp Cap (vph)	181	285	1961		997	3844
v/s Ratio Prot			c0.34		c0.26	0.22
v/s Ratio Perm	0.04	c0.06				
v/c Ratio	0.36	0.56	0.89		0.91	0.30
Uniform Delay, d1	38.5	39.3	26.7		31.7	3.9
Progression Factor	1.00	1.00	1.00		1.00	1.00
Incremental Delay, d2	1.3	2.4	5.7		12.5	0.0
Delay (s)	39.7	41.6	32.4		44.2	4.0
Level of Service	D	D	C		D	A
Approach Delay (s)	41.5		32.4			21.7
Approach LOS	D		C			C

Intersection Summary

HCM 2000 Control Delay	29.7	HCM 2000 Level of Service	C
HCM 2000 Volume to Capacity ratio	0.83		
Actuated Cycle Length (s)	91.6	Sum of lost time (s)	19.5
Intersection Capacity Utilization	79.2%	ICU Level of Service	D
Analysis Period (min)	15		
c Critical Lane Group			

HCM 2010 Signalized Intersection Summary
 1: Cayote Canyon Rd & Duncan Canyon Rd

Horizon (Yr 2040) W/ Project PM
 02/27/2019

												
Movement	EBL	EBT	EBR	WBL	WBT	WBR	NBL	NBT	NBR	SBL	SBT	SBR
Lane Configurations												
Traffic Volume (veh/h)	22	312	15	179	431	701	13	1	110	460	0	6
Future Volume (veh/h)	22	312	15	179	431	701	13	1	110	460	0	6
Number	5	2	12	1	6	16	3	8	18	7	4	14
Initial Q (Qb), veh	0	0	0	0	0	0	0	0	0	0	0	0
Ped-Bike Adj(A_pbT)	1.00		1.00	1.00		1.00	1.00		1.00	1.00		1.00
Parking Bus, Adj	1.00	1.00	1.00	1.00	1.00	1.00	1.00	1.00	1.00	1.00	1.00	1.00
Adj Sat Flow, veh/h/ln	1900	1900	1900	1900	1900	1900	1900	1900	1900	1900	1900	1900
Adj Flow Rate, veh/h	23	328	16	188	454	738	14	1	116	484	0	6
Adj No. of Lanes	1	2	0	1	2	0	1	1	1	1	1	1
Peak Hour Factor	0.95	0.95	0.95	0.95	0.95	0.95	0.95	0.95	0.95	0.95	0.95	0.95
Percent Heavy Veh, %	0	0	0	0	0	0	0	0	0	0	0	0
Cap, veh/h	80	1315	64	218	816	730	0	150	323	509	534	454
Arrive On Green	0.04	0.38	0.38	0.12	0.45	0.45	0.08	0.08	0.08	0.28	0.00	0.28
Sat Flow, veh/h	1810	3505	170	1810	1805	1615	0	1900	1615	1810	1900	1615
Grp Volume(v), veh/h	23	168	176	188	454	738	0	1	116	484	0	6
Grp Sat Flow(s),veh/h/ln	1810	1805	1870	1810	1805	1615	0	1900	1615	1810	1900	1615
Q Serve(g_s), s	1.5	8.0	8.1	12.7	23.0	56.5	0.0	0.1	7.7	32.8	0.0	0.3
Cycle Q Clear(g_c), s	1.5	8.0	8.1	12.7	23.0	56.5	0.0	0.1	7.7	32.8	0.0	0.3
Prop In Lane	1.00		0.09	1.00		1.00	0.00		1.00	1.00		1.00
Lane Grp Cap(c), veh/h	80	677	702	218	816	730	0	150	323	509	534	454
V/C Ratio(X)	0.29	0.25	0.25	0.86	0.56	1.01	0.00	0.01	0.36	0.95	0.00	0.01
Avail Cap(c_a), veh/h	145	677	702	369	816	730	0	363	503	528	555	471
HCM Platoon Ratio	1.00	1.00	1.00	1.00	1.00	1.00	1.00	1.00	1.00	1.00	1.00	1.00
Upstream Filter(I)	1.00	1.00	1.00	1.00	1.00	1.00	0.00	1.00	1.00	1.00	0.00	1.00
Uniform Delay (d), s/veh	57.9	26.9	26.9	54.0	25.1	34.3	0.0	53.0	43.1	44.1	0.0	32.4
Incr Delay (d2), s/veh	2.0	0.2	0.2	10.2	0.8	36.1	0.0	0.0	0.7	27.0	0.0	0.0
Initial Q Delay(d3),s/veh	0.0	0.0	0.0	0.0	0.0	0.0	0.0	0.0	0.0	0.0	0.0	0.0
%ile BackOfQ(50%),veh/ln	0.8	4.1	4.2	7.0	11.7	32.5	0.0	0.0	3.5	20.2	0.0	0.2
LnGrp Delay(d),s/veh	59.8	27.1	27.1	64.2	25.9	70.4	0.0	53.1	43.8	71.1	0.0	32.4
LnGrp LOS	E	C	C	E	C	F		D	D	E		C
Approach Vol, veh/h		367			1380			117			490	
Approach Delay, s/veh		29.2			54.9			43.9			70.6	
Approach LOS		C			D			D			E	
Timer	1	2	3	4	5	6	7	8				
Assigned Phs	1	2		4	5	6		8				
Phs Duration (G+Y+Rc), s	19.6	51.4		39.6	10.0	61.0		14.4				
Change Period (Y+Rc), s	4.5	4.5		4.5	4.5	4.5		* 4.5				
Max Green Setting (Gmax), s	25.5	41.0		36.5	10.0	56.5		* 24				
Max Q Clear Time (g_c+I1), s	14.7	10.1		34.8	3.5	58.5		9.7				
Green Ext Time (p_c), s	0.3	1.9		0.3	0.0	0.0		0.2				
Intersection Summary												
HCM 2010 Ctrl Delay			53.6									
HCM 2010 LOS			D									
Notes												

Intersection						
Int Delay, s/veh	2.3					
Movement	EBT	EBR	WBL	WBT	NBL	NBR
Lane Configurations						
Traffic Vol, veh/h	226	12	29	271	29	79
Future Vol, veh/h	226	12	29	271	29	79
Conflicting Peds, #/hr	0	0	0	0	0	0
Sign Control	Free	Free	Free	Free	Stop	Stop
RT Channelized	-	None	-	None	-	None
Storage Length	-	-	-	-	0	-
Veh in Median Storage, #	0	-	-	0	0	-
Grade, %	0	-	-	0	0	-
Peak Hour Factor	95	95	95	95	95	95
Heavy Vehicles, %	0	0	0	0	0	0
Mvmt Flow	238	13	31	285	31	83

Major/Minor	Major1	Major2	Minor1		
Conflicting Flow All	0	0	251	0	592 245
Stage 1	-	-	-	-	245 -
Stage 2	-	-	-	-	347 -
Critical Hdwy	-	-	4.1	-	6.4 6.2
Critical Hdwy Stg 1	-	-	-	-	5.4 -
Critical Hdwy Stg 2	-	-	-	-	5.4 -
Follow-up Hdwy	-	-	2.2	-	3.5 3.3
Pot Cap-1 Maneuver	-	-	1326	-	472 799
Stage 1	-	-	-	-	800 -
Stage 2	-	-	-	-	720 -
Platoon blocked, %	-	-	-	-	-
Mov Cap-1 Maneuver	-	-	1326	-	459 799
Mov Cap-2 Maneuver	-	-	-	-	459 -
Stage 1	-	-	-	-	778 -
Stage 2	-	-	-	-	720 -

Approach	EB	WB	NB
HCM Control Delay, s	0	0.8	11.5
HCM LOS			B

Minor Lane/Major Mvmt	NBLn1	EBT	EBR	WBL	WBT
Capacity (veh/h)	666	-	-	1326	-
HCM Lane V/C Ratio	0.171	-	-	0.023	-
HCM Control Delay (s)	11.5	-	-	7.8	0
HCM Lane LOS	B	-	-	A	A
HCM 95th %tile Q(veh)	0.6	-	-	0.1	-

Intersection

Int Delay, s/veh 5.7

Movement	EBL	EBT	WBT	WBR	SBL	SBR
Lane Configurations		↕	↕		↕	
Traffic Vol, veh/h	0	315	100	291	250	0
Future Vol, veh/h	0	315	100	291	250	0
Conflicting Peds, #/hr	0	0	0	0	0	0
Sign Control	Free	Free	Free	Free	Stop	Stop
RT Channelized	-	None	-	None	-	None
Storage Length	-	-	-	-	0	-
Veh in Median Storage, #	-	0	0	-	0	-
Grade, %	-	0	0	-	0	-
Peak Hour Factor	95	95	95	95	95	95
Heavy Vehicles, %	0	0	0	0	0	0
Mvmt Flow	0	332	105	306	263	0











Major/Minor	Major1	Major2	Minor2
Conflicting Flow All	411	0	590
Stage 1	-	-	258
Stage 2	-	-	332
Critical Hdwy	4.1	-	6.4
Critical Hdwy Stg 1	-	-	5.4
Critical Hdwy Stg 2	-	-	5.4
Follow-up Hdwy	2.2	-	3.5
Pot Cap-1 Maneuver	1159	-	474
Stage 1	-	-	790
Stage 2	-	-	731
Platoon blocked, %	-	-	-
Mov Cap-1 Maneuver	1159	-	474
Mov Cap-2 Maneuver	-	-	474
Stage 1	-	-	790
Stage 2	-	-	731

Approach	EB	WB	SB
HCM Control Delay, s	0	0	21.7
HCM LOS			C

Minor Lane/Major Mvmt	EBL	EBT	WBT	WBR	SBLn1
Capacity (veh/h)	1159	-	-	-	474
HCM Lane V/C Ratio	-	-	-	-	0.555
HCM Control Delay (s)	0	-	-	-	21.7
HCM Lane LOS	A	-	-	-	C
HCM 95th %tile Q(veh)	0	-	-	-	3.3

HCM 2010 Signalized Intersection Summary
6: Sierra Ave & Lytle Creek Rd (W/ Realignment)

Horizon (Yr 2040) W/ Project PM
02/27/2019

								
Movement	EBL	EBR	NBL	NBT	SBT	SBR		
Lane Configurations								
Traffic Volume (veh/h)	9	503	382	1140	644	7		
Future Volume (veh/h)	9	503	382	1140	644	7		
Number	3	18	1	6	2	12		
Initial Q (Qb), veh	0	0	0	0	0	0		
Ped-Bike Adj(A_pbT)	1.00	1.00	1.00			1.00		
Parking Bus, Adj	1.00	1.00	1.00	1.00	1.00	1.00		
Adj Sat Flow, veh/h/ln	1900	1900	1900	1900	1900	1900		
Adj Flow Rate, veh/h	9	529	402	1200	678	7		
Adj No. of Lanes	0	0	1	2	2	0		
Peak Hour Factor	0.95	0.95	0.95	0.95	0.95	0.95		
Percent Heavy Veh, %	0	0	0	0	0	0		
Cap, veh/h	9	546	455	1769	840	9		
Arrive On Green	0.34	0.37	0.18	0.49	0.23	0.25		
Sat Flow, veh/h	27	1588	1810	3705	3756	38		
Grp Volume(v), veh/h	539	0	402	1200	334	351		
Grp Sat Flow(s),veh/h/ln	1618	0	1810	1805	1805	1893		
Q Serve(g_s), s	25.6	0.0	12.7	19.8	13.7	13.7		
Cycle Q Clear(g_c), s	25.6	0.0	12.7	19.8	13.7	13.7		
Prop In Lane	0.02	0.98	1.00			0.02		
Lane Grp Cap(c), veh/h	556	0	455	1769	414	434		
V/C Ratio(X)	0.97	0.00	0.88	0.68	0.81	0.81		
Avail Cap(c_a), veh/h	673	0	910	3442	797	836		
HCM Platoon Ratio	1.00	1.00	1.00	1.00	1.00	1.00		
Upstream Filter(I)	1.00	0.00	1.00	1.00	1.00	1.00		
Uniform Delay (d), s/veh	24.3	0.0	18.5	15.2	28.5	28.5		
Incr Delay (d2), s/veh	25.1	0.0	5.8	0.5	3.8	3.6		
Initial Q Delay(d3),s/veh	0.0	0.0	0.0	0.0	0.0	0.0		
%ile BackOfQ(50%),veh/ln	15.2	0.0	6.9	9.9	7.2	7.5		
LnGrp Delay(d),s/veh	49.4	0.0	24.3	15.7	32.2	32.1		
LnGrp LOS	D		C	B	C	C		
Approach Vol, veh/h	539			1602	685			
Approach Delay, s/veh	49.4			17.8	32.2			
Approach LOS	D			B	C			
Timer	1	2	3	4	5	6	7	8
Assigned Phs	1	2				6		8
Phs Duration (G+Y+Rc), s	20.4	24.4				44.8		33.3
Change Period (Y+Rc), s	4.5	4.5				4.5		4.5
Max Green Setting (Gmax), s	35.5	36.5				76.5		34.5
Max Q Clear Time (g_c+I1), s	14.7	15.7				21.8		27.6
Green Ext Time (p_c), s	1.2	4.2				12.6		1.3
Intersection Summary								
HCM 2010 Ctrl Delay			27.3					
HCM 2010 LOS			C					
Notes								

HCM 2010 Signalized Intersection Summary
 7: Sierra Ave & I-15 SB Ramps

Horizon (Yr 2040) W/ Project PM
 02/27/2019



Movement	EBL	EBT	EBR	WBL	WBT	WBR	NBL	NBT	NBR	SBL	SBT	SBR
Lane Configurations				↖ ↗	↖		↖	↖ ↗			↖ ↗	↖
Traffic Volume (veh/h)	0	0	0	1135	4	280	398	1576	0	0	823	616
Future Volume (veh/h)	0	0	0	1135	4	280	398	1576	0	0	823	616
Number				7	4	14	1	6	16	5	2	12
Initial Q (Qb), veh				0	0	0	0	0	0	0	0	0
Ped-Bike Adj(A_pbT)				1.00		1.00	1.00		1.00	1.00		1.00
Parking Bus, Adj				1.00	1.00	1.00	1.00	1.00	1.00	1.00	1.00	1.00
Adj Sat Flow, veh/h/ln				1900	1900	1900	1900	1900	0	0	1900	1900
Adj Flow Rate, veh/h				1195	4	295	419	1659	0	0	866	648
Adj No. of Lanes				2	1	0	1	2	0	0	2	1
Peak Hour Factor				0.95	0.95	0.95	0.95	0.95	0.95	0.95	0.95	0.95
Percent Heavy Veh, %				0	0	0	0	0	0	0	0	0
Cap, veh/h				1188	7	540	334	2055	0	0	1250	559
Arrive On Green				0.34	0.34	0.34	0.37	1.00	0.00	0.00	0.35	0.35
Sat Flow, veh/h				3510	22	1597	1810	3705	0	0	3705	1615
Grp Volume(v), veh/h				1195	0	299	419	1659	0	0	866	648
Grp Sat Flow(s),veh/h/ln				1755	0	1618	1810	1805	0	0	1805	1615
Q Serve(g_s), s				44.0	0.0	19.5	24.0	0.0	0.0	0.0	26.8	45.0
Cycle Q Clear(g_c), s				44.0	0.0	19.5	24.0	0.0	0.0	0.0	26.8	45.0
Prop In Lane				1.00		0.99	1.00		0.00	0.00		1.00
Lane Grp Cap(c), veh/h				1188	0	548	334	2055	0	0	1250	559
V/C Ratio(X)				1.01	0.00	0.55	1.25	0.81	0.00	0.00	0.69	1.16
Avail Cap(c_a), veh/h				1188	0	548	334	2055	0	0	1250	559
HCM Platoon Ratio				1.00	1.00	1.00	2.00	2.00	1.00	1.00	1.00	1.00
Upstream Filter(I)				1.00	0.00	1.00	0.09	0.09	0.00	0.00	0.73	0.73
Uniform Delay (d), s/veh				43.0	0.0	34.9	41.0	0.0	0.0	0.0	36.6	42.5
Incr Delay (d2), s/veh				27.5	0.0	1.1	116.8	0.3	0.0	0.0	2.3	85.8
Initial Q Delay(d3),s/veh				0.0	0.0	0.0	0.0	0.0	0.0	0.0	0.0	0.0
%ile BackOfQ(50%),veh/ln				25.8	0.0	8.9	22.7	0.1	0.0	0.0	13.8	33.4
LnGrp Delay(d),s/veh				70.5	0.0	36.0	157.8	0.3	0.0	0.0	38.9	128.3
LnGrp LOS				F		D	F	A			D	F
Approach Vol, veh/h					1494			2078			1514	
Approach Delay, s/veh					63.6			32.1			77.2	
Approach LOS					E			C			E	
Timer	1	2	3	4	5	6	7	8				
Assigned Phs	1	2		4		6						
Phs Duration (G+Y+Rc), s	29.0	51.0		50.0		80.0						
Change Period (Y+Rc), s	5.0	6.0		6.0		6.0						
Max Green Setting (Gmax), s	24.0	45.0		44.0		74.0						
Max Q Clear Time (g_c+20), s	20.0	47.0		46.0		2.0						
Green Ext Time (p_c), s	0.0	0.0		0.0		24.0						
Intersection Summary												
HCM 2010 Ctrl Delay				54.8								
HCM 2010 LOS				D								

HCM 2010 Signalized Intersection Summary
 8: Sierra Ave & I-15 NB Ramps

Horizon (Yr 2040) W/ Project PM
 02/27/2019



Movement	EBL	EBT	EBR	WBL	WBT	WBR	NBL	NBT	NBR	SBL	SBT	SBR
Lane Configurations												
Traffic Volume (veh/h)	933	0	782	0	0	0	0	1041	1686	388	1570	0
Future Volume (veh/h)	933	0	782	0	0	0	0	1041	1686	388	1570	0
Number	3	8	18				1	6	16	5	2	12
Initial Q (Qb), veh	0	0	0				0	0	0	0	0	0
Ped-Bike Adj(A_pbT)	1.00		1.00				1.00		1.00	1.00		1.00
Parking Bus, Adj	1.00	1.00	1.00				1.00	1.00	1.00	1.00	1.00	1.00
Adj Sat Flow, veh/h/ln	1900	1900	1900				0	1900	1900	1900	1900	0
Adj Flow Rate, veh/h	1238	0	549				0	1096	1775	408	1653	0
Adj No. of Lanes	2	0	1				0	2	1	1	2	0
Peak Hour Factor	0.95	0.95	0.95				0.95	0.95	0.95	0.95	0.95	0.95
Percent Heavy Veh, %	0	0	0				0	0	0	0	0	0
Cap, veh/h	1375	0	614				0	920	411	424	1905	0
Arrive On Green	0.38	0.00	0.38				0.00	0.25	0.25	0.47	1.00	0.00
Sat Flow, veh/h	3619	0	1615				0	3705	1615	1810	3705	0
Grp Volume(v), veh/h	1238	0	549				0	1096	1775	408	1653	0
Grp Sat Flow(s),veh/h/ln	1810	0	1615				0	1805	1615	1810	1805	0
Q Serve(g_s), s	41.9	0.0	41.5				0.0	33.1	33.1	28.3	0.0	0.0
Cycle Q Clear(g_c), s	41.9	0.0	41.5				0.0	33.1	33.1	28.3	0.0	0.0
Prop In Lane	1.00		1.00				0.00		1.00	1.00		0.00
Lane Grp Cap(c), veh/h	1375	0	614				0	920	411	424	1905	0
V/C Ratio(X)	0.90	0.00	0.89				0.00	1.19	4.31	0.96	0.87	0.00
Avail Cap(c_a), veh/h	1503	0	671				0	920	411	445	1905	0
HCM Platoon Ratio	1.00	1.00	1.00				1.00	1.00	1.00	2.00	2.00	1.00
Upstream Filter(l)	1.00	0.00	1.00				0.00	0.14	0.14	0.39	0.39	0.00
Uniform Delay (d), s/veh	38.0	0.0	37.9				0.0	48.4	48.4	33.9	0.0	0.0
Incr Delay (d2), s/veh	7.4	0.0	13.8				0.0	88.0	1492.2	17.4	2.3	0.0
Initial Q Delay(d3),s/veh	0.0	0.0	0.0				0.0	0.0	0.0	0.0	0.0	0.0
%ile BackOfQ(50%),veh/ln	22.4	0.0	20.8				0.0	27.7	185.3	16.1	0.6	0.0
LnGrp Delay(d),s/veh	45.3	0.0	51.7				0.0	136.4	1540.7	51.3	2.3	0.0
LnGrp LOS	D		D					F	F	D	A	
Approach Vol, veh/h		1787						2871			2061	
Approach Delay, s/veh		47.3						1004.6			12.0	
Approach LOS		D						F			B	
Timer	1	2	3	4	5	6	7	8				
Assigned Phs		2			5	6		8				
Phs Duration (G+Y+Rc), s		74.6			35.5	39.1		55.4				
Change Period (Y+Rc), s		6.0			5.0	6.0		6.0				
Max Green Setting (Gmax), s		64.0			32.0	27.0		54.0				
Max Q Clear Time (g_c+11), s		2.0			30.3	35.1		43.9				
Green Ext Time (p_c), s		22.9			0.1	0.0		5.5				
Intersection Summary												
HCM 2010 Ctrl Delay			445.5									
HCM 2010 LOS			F									
Notes												

HCM Signalized Intersection Capacity Analysis
 9: Sierra Ave & Riverside Ave

Horizon (Yr 2040) W/ Project PM
 With Mitigation 05/16/2018



Movement	WBL	WBR	NBT	NBR	SBL	SBT
Lane Configurations	↶	↶↶	↶↶↶		↶↶	↶↶↶
Traffic Volume (vph)	31	1121	1606	29	827	1525
Future Volume (vph)	31	1121	1606	29	827	1525
Ideal Flow (vphpl)	1900	1900	1900	1900	1900	1900
Total Lost time (s)	6.5	6.5	8.0		7.0	8.0
Lane Util. Factor	1.00	0.88	0.91		0.97	0.91
Frt	1.00	0.85	1.00		1.00	1.00
Flt Protected	0.95	1.00	1.00		0.95	1.00
Satd. Flow (prot)	1805	2842	5173		3502	5187
Flt Permitted	0.95	1.00	1.00		0.95	1.00
Satd. Flow (perm)	1805	2842	5173		3502	5187
Peak-hour factor, PHF	0.95	0.95	0.95	0.95	0.95	0.95
Adj. Flow (vph)	33	1180	1691	31	871	1605
RTOR Reduction (vph)	0	672	2	0	0	0
Lane Group Flow (vph)	33	508	1720	0	871	1605
Heavy Vehicles (%)	0%	0%	0%	0%	0%	0%
Turn Type	Perm	Perm	NA		Prot	NA
Protected Phases			6		5	2
Permitted Phases	4	4				
Actuated Green, G (s)	20.7	20.7	35.6		27.0	67.6
Effective Green, g (s)	18.7	18.7	33.6		25.0	65.6
Actuated g/C Ratio	0.19	0.19	0.34		0.25	0.66
Clearance Time (s)	4.5	4.5	6.0		5.0	6.0
Vehicle Extension (s)	3.0	3.0	3.0		3.0	3.0
Lane Grp Cap (vph)	341	537	1759		886	3444
v/s Ratio Prot			c0.33		c0.25	0.31
v/s Ratio Perm	0.02	c0.18				
v/c Ratio	0.10	0.95	0.98		0.98	0.47
Uniform Delay, d1	33.1	39.5	32.2		36.7	8.1
Progression Factor	1.00	1.00	1.00		1.00	1.00
Incremental Delay, d2	0.1	25.7	16.3		25.9	0.1
Delay (s)	33.2	65.3	48.5		62.6	8.2
Level of Service	C	E	D		E	A
Approach Delay (s)	64.4		48.5			27.3
Approach LOS	E		D			C

Intersection Summary			
HCM 2000 Control Delay		42.4	HCM 2000 Level of Service D
HCM 2000 Volume to Capacity ratio		0.95	
Actuated Cycle Length (s)		98.8	Sum of lost time (s) 19.5
Intersection Capacity Utilization		83.0%	ICU Level of Service E
Analysis Period (min)		15	
c Critical Lane Group			