

CONCRETE

1. ALL CONCRETE SHALL CONFORM TO THE LATEST EDITION OF THE CALIFORNIA BUILDING CODE AND ACI 318.
2. CONCRETE SHALL BE DESIGNED AND TESTED AS OUTLINED IN THE PROJECT SPECIFICATIONS.
3. NO WATER SHALL BE ADDED ON SITE.
4. ALL CEMENT SHALL CONFORM TO ASTM C150. APPROPRIATE CEMENT TYPE AND CONCRETE STRENGTH AND SHALL BE SELECTED BASED ON EXPOSURE TO SOILS AND OR MATERIALS CAUSING SULFATE ATTACK PER CBC TABLE 1904.3.
5. FINE AND COARSE AGGREGATE SHALL CONFORM TO ASTM C33 FOR STANDARD WEIGHT CONCRETE AND ASTM C330 FOR LIGHT WEIGHT CONCRETE.
6. ALL AGGREGATE SHALL WELL GRADED AND SHRINKAGE SHALL BE AS PER ASTM C157 W/ THE AVERAGE DRYING SHRINKAGE AT 28-DAYS NOT EXCEEDING 0.04%.
7. CHEMICAL ADMIXTURES SHALL CONFORM TO ASTM C494, HIGH RANGE WATER REDUCING (TYPE G) WHERE USED.
8. AIR ENTRAINING ADMIXTURES SHALL CONFORM TO ASTM C260 WHERE USED
9. DRYPACK SHALL BE COMPOSED OF ONE PART PORTLAND CEMENT TO NOT MORE THAT THREE PARTS SAND.
10. ANCHOR BOLTS, HOLDOWN BOLTS, DOWELS, INSERTS, ETC. SHALL BE SECURELY TIED IN PLACE PRIOR TO PLACING CONCRETE.
11. CONCRETE SHALL BE CURED BY KEEPING CONTINUOUSLY WET FOR 10-DAYS OR BY AN APPROVED CURING COMPOUND CONFORMING TO ASTM C1315, CLEAR TYPE I, CLASS A, WATERBORNE.
12. CONCRETE STRENGTHS:
 STRUCTURAL CONCRETE $f_c = 3,000$ psi
 SLABS-ON-GRADE $f_c = 2,500$ psi
 CONTINUOUS FOOTINGS AND PADS $f_c = 2,500$ PSI
 WATER / CEMENT RATIO = 0.45
 TYPE I/III CEMENT UNO
 ALL CONCRETE SHALL REACH MINIMUM COMPRESSIVE STRENGTH AT 28 DAYS. PROVIDE CONCRETE MIX TO MEET ACI REQUIREMENTS FOR SULFATE EXPOSURE PER SITE SOIL TYPE. FIELD VERIFY.
13. UNLESS NOTED OTHERWISE, FOOTINGS, FOUNDATIONS, AND SLABS ON GRADE DO NOT REQUIRE SPECIAL INSPECTION. HOWEVER ALL OTHER STRUCTURAL CONCRETE w/ SPECIFIED f_c GREATER THAN 2,500 psi SHALL HAVE SPECIAL INSPECTION PER SECTION 1704 OF THE CALIFORNIA BUILDING CODE UNLESS NOTED OTHERWISE.
14. CONCRETE FOR EXTERIOR SLABS ON GRADE SHALL HAVE A MAXIMUM OF 4" OF SLUMP PER ASTM C143. MAXIMUM WATER TO CEMENT RATIO =0.45. EXTERIOR SLABS TO BE DESIGNED FOR "SEVERE EXPOSURE" PER SECTION 4.2.1 OF ACI 318-11.



www.sbcounty.gov

SB County
12'x17'-4"
Enclosure

General Notes

Project number	Project Number
Date	Issue Date
Drawn by	Author
Checked by	Checker

A1

Scale

STRUCTURAL STEEL

1. ALL STRUCTURAL AND MISCELLANEOUS STEEL SHALL CONFORM TO THE FIFTEENTH EDITION OF THE AISC "SPECIFICATION FOR THE DESIGN, FABRICATION AND ERECTION OF STRUCTURAL STEEL FOR BUILDINGS" AND ALL ITS SUPPLEMENTS, AND TO THE AISC "CODE OF STANDARD PRACTICE FOR STEEL BUILDINGS AND BRIDGES."
2. ALL STRUCTURAL WIDE FLANG STEEL SHAPES SHALL HAVE A MIN. YIELD STRENGTH OF 50,000 psi , UNLESS NOTED OTHERWISE.
3. ALL STRUCTURAL AND MISCELLANEOUS STEEL SHALL CONFORM TO ASTM -36 HAVING A MINIMUM YIELD STRENGTH OF 36,000 psi. UNLESS NOTED OTHERWISE.
4. ALL CONNECTIONS, EXCEPT AS NOTED ON PLANS AND DETAILS, SHALL BE BOLTED OR WELDED CONNECTIONS AS SHOWN IN THE FIFTEENTH EDITION OF THE AISC MANUAL. ALL BEAM CONNECTIONS SHALL DEVELOP THE FULL UNIFORM LOAD CAPACITY THE MEMBER CAN CARRY WITH DUE CONSIDERATION TO CONCENTRATED LOADS AT THE ENDS OF THE MEMBER.
5. ALL BOLTED CONNECTIONS SHALL USE 3/4" Ø MINIMUM ASTM A325 HIGH STRENGTH BOLTS, U.N.O. NO CONNECTION SHALL BE MADE USING LESS THAN TWO BOLTS.
6. WELDING SHALL BE IN ACCORDANCE WITH THE LATEST EDITION OF THE "STRUCTURAL WELDING CODE", AWS D1.1 OF THE AMERICAN WELDING SOCIETY. ALL SHOP AND FIELD WELDING SHALL BE DONE BY CERTIFIED WELDERS QUALIFIED IN ACCORDANCE WITH AMERICAN WELDING SOCIETY STANDARDS. ALL WELDED CONNECTIONS SHALL BE PERFORMED USING E70XX ELECTRODES.
7. ALL ANCHOR BOLTS SHALL BE ASTM A-307. ANCHOR BOLT LENGTHS SHOWN ARE EMBEDDED LENGTHS.
8. STRUCTURAL STEEL TUBING SHALL BE ASTM A500.
9. SHOP PAINTING - ONE COAT RUSTOLEUM #678 OR EQUAL. PREPARATION FOR PAINTING SHALL CONFORM TO REQUIREMENTS OF SSPC-SP2.



www.sbcounty.gov

SB County
12'x17'-4"
Enclosure

General Notes

Project number	Project Number	A1.1
Date	Issue Date	
Drawn by	Author	
Checked by	Checker	
		Scale

MASONRY

1. ALL MASONRY CONSTRUCTION SHALL CONFORM TO THE CURRENT PROVISIONS OF THE BUILDING CODE REGULATIONS FOR MASONRY STRUCTURES - ACI 530 (ASCE 5), AND SPECIFICATIONS FOR MASONRY STRUCTURES - ACI 530.1 (ASCE 6).
2. ASSUMED COMPRESSIVE STRENGTH OF MASONRY, $f_m = 1350$ psi @ 28 DAYS.
3. ALL CONCRETE MASONRY UNITS SHALL CONFORM TO ASTM C 90, GRADE N-1, NORMAL WEIGHT.
4. MORTAR FOR ALL WORK SHALL BE TYPE S.
5. GROUT FOR FILLING SHALL HAVE A MINIMUM COMPRESSIVE STRENGTH (f_m) OF 2000 psi, AND SHALL CONFORM TO ASTM C476. PLACE GROUT FILL IN 4'-0" MAXIMUM LIFTS VERTICALLY.
6. ALL REINFORCING BARS FOR REINFORCED MASONRY CONSTRUCTION SHALL CONFORM TO ASTM A-615 GRADE 60. LAP LENGTH SHALL BE MINIMUM 40 BAR DIAMETERS.
7. PROVIDE 100% SOLID MASONRY BELOW ALL LINTEL BEARINGS 12" BEYOND THE OPENING FOR THE FULL WALL WIDTH AT ALL LINTELS FROM THE LINTEL BEARING TO THE FLOOR BELOW.
8. PROVIDE ONE 8" COURSE OF SOLID MASONRY AT JOIST AND BEAM BEARING LINES, UNLESS NOTED OTHERWISE.
9. BRACE AND SHORE ALL MASONRY WALLS AS REQUIRED THROUGHOUT THE COMPACTION AND CONSTRUCTION PROCESS UNTIL THE GROUND FLOOR SLAB AND SUPPORTING FLOORS OR ROOF HAVE BEEN COMPLETELY INSTALLED.

REINFORCING STEEL

1. ALL REINFORCING SHALL BE ASTM A615, GRADE 60.
2. WELDED WIRE FABRIC SHALL CONFORM TO ASTM A185 FLAT SHEETS NOT ROLLS. LAP 1-1/2 SPACES, 9" MINIMUM FOR STRUCTURAL SLABS.
3. ALL BARS SHALL BE DEFORMED AS PER ASTM A305.
4. ALL BARS SHALL BE CLEAN OF LOOSE FLAKY RUST, GREASE OR OTHER MATERIALS LIKELY TO IMPAIR BOND.
5. ALL BENDS SHALL BE MADE COLD.
6. SPLICING OF BARS SHALL HAVE LAPS OF 30 BAR DIAMETERS OR 2'-0" MINIMUM FOR ALL CONTINUOUS REINFORCEMENT OF FOOTINGS AND CONCRETE WALLS, UNLESS OTHERWISE NOTED ON PLANS. MASONRY REINFORCEMENT SHALL HAVE LAPS OF 40 BAR DIAMETERS OR 2'-0", WHICHEVER IS GREATER.
7. ALL REINFORCING BARS SHALL BE ACCURATELY AND SECURELY PLACED BEFORE PLACING CONCRETE.
8. CONCRETE PROTECTION FOR REINFORCEMENT SHALL BE AT LEAST EQUAL TO THE DIAMETER OF THE BARS. MINIMUM COVER SHALL BE AS FOLLOWS:
 - A. POURED AGAINST EARTH 3"
 - B. SLABS ON GRADE (FROM TOP OF SLAB) 1"
 - C. WALLS: - EXPOSED TO WEATHER 2"
- NOT EXPOSED TO WEATHER #11 AND SMALLER 1"



www.sbcounty.gov

SB County
12'x17'-4"
Enclosure

General Notes

Project number	Project Number	A1.2
Date	Issue Date	
Drawn by	Author	
Checked by	Checker	Scale

By using these standard plans, the user agrees to release the County of San Bernardino from any and all claims, liabilities, suits, and demands on account of any injury, damage, or loss to persons or property, including injury or death, or economic losses, arising out of the use of these construction documents. The use of these plans does not eliminate or reduce the user's responsibility to verify any and all information

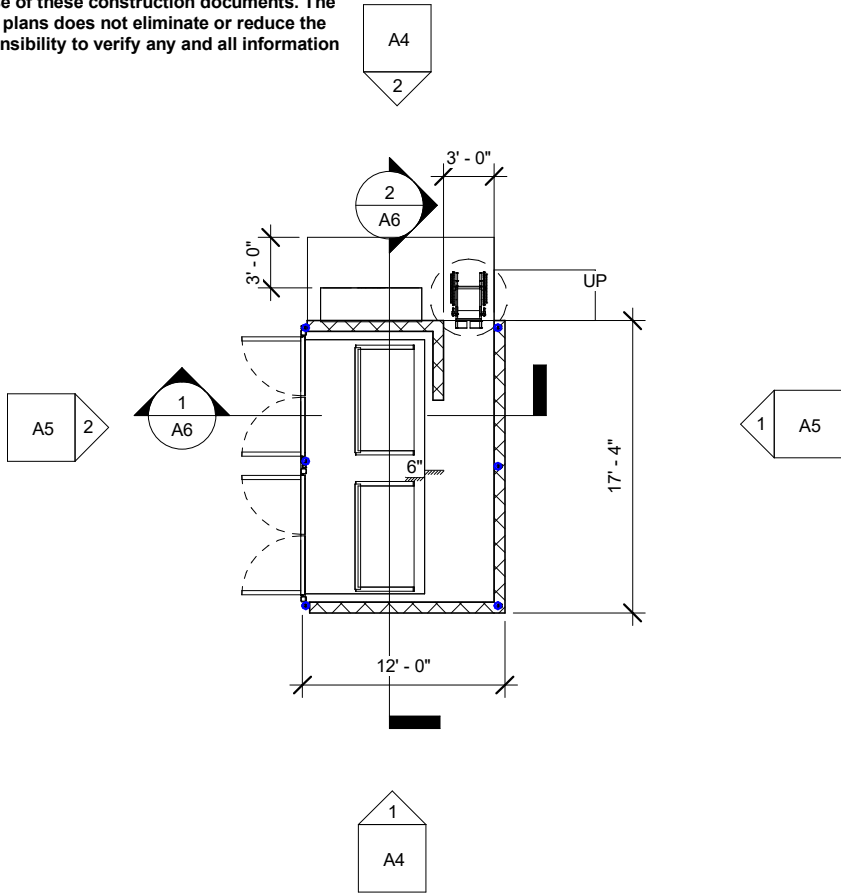

① Level 1
1/8" = 1'-0"



www.sbcounty.gov

SB County
12'x17'-4"
Enclosure

First Floor

Project number	Project Number
Date	Issue Date
Drawn by	Author
Checked by	Checker

A2

Scale 1/8" = 1'-0"

By using these standard plans, the user agrees to release the County of San Bernardino from any and all claims, liabilities, suits, and demands on account of any injury, damage, or loss to persons or property, including injury or death, or economic losses, arising out of the use of these construction documents. The use of these plans does not eliminate or reduce the user's responsibility to verify any and all information

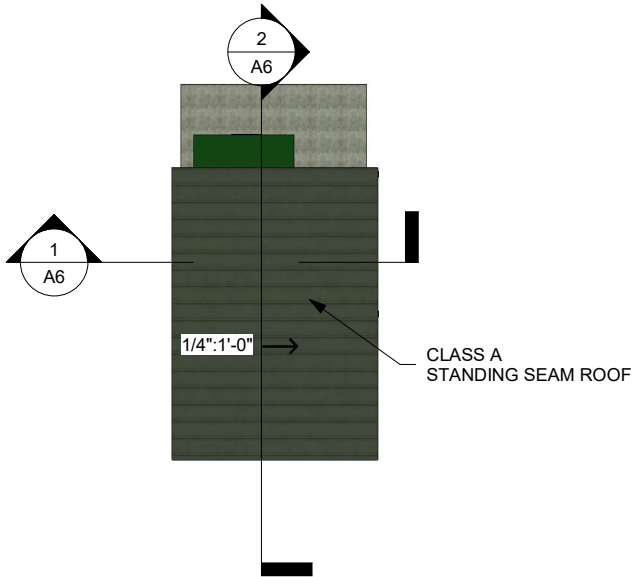

① Roof
1/8" = 1'-0"



www.sbcounty.gov

SB County
12'x17'-4"
Enclosure

Roof Plan

Project number	Project Number
Date	Issue Date
Drawn by	Author
Checked by	Checker

A3

Scale 1/8" = 1'-0"

By using these standard plans, the user agrees to release the County of San Bernardino from any and all claims, liabilities, suits, and demands on account of any injury, damage, or loss to persons or property, including injury or death, or economic losses, arising out of the use of these construction documents. The use of these plans does not eliminate or reduce the user's responsibility to verify any and all information

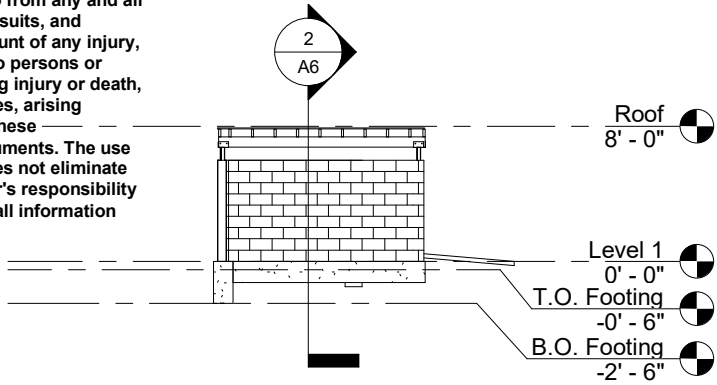

① South
1/8" = 1'-0"

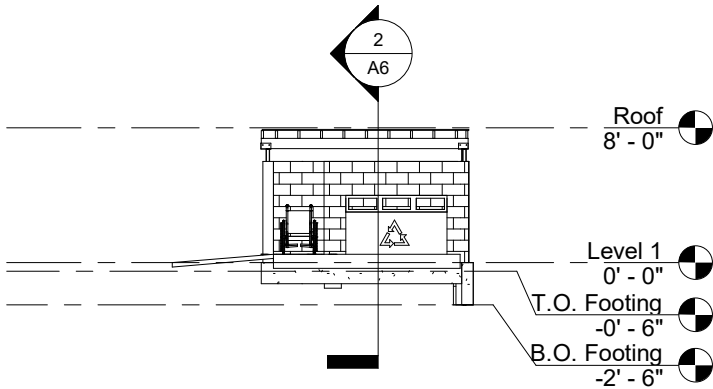

② North
1/8" = 1'-0"



www.sbcounty.gov

SB County
12'x17'-4"
Enclosure

Elevations

Project number	Project Number
Date	Issue Date
Drawn by	Author
Checked by	Checker

A4

Scale 1/8" = 1'-0"

By using these standard plans, the user agrees to release the County of San Bernardino from any and all claims, liabilities, suits, and demands on account of any injury, damage, or loss to persons or property, including injury or death, or economic losses, arising out of the use of these construction documents. The use of these plans does not eliminate or reduce the user's responsibility to verify any and all information

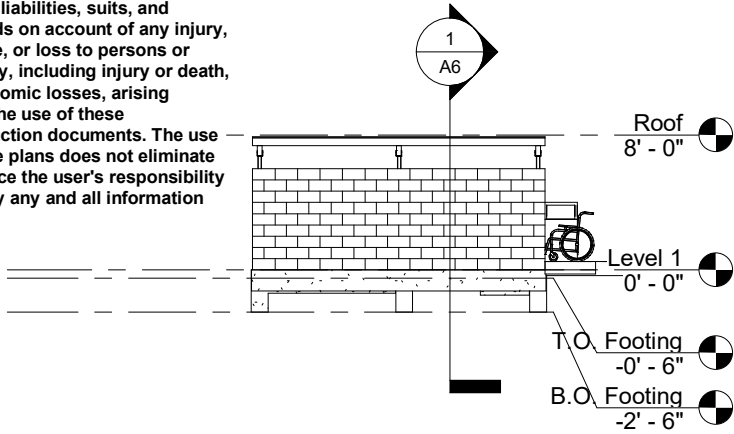

① East
1/8" = 1'-0"

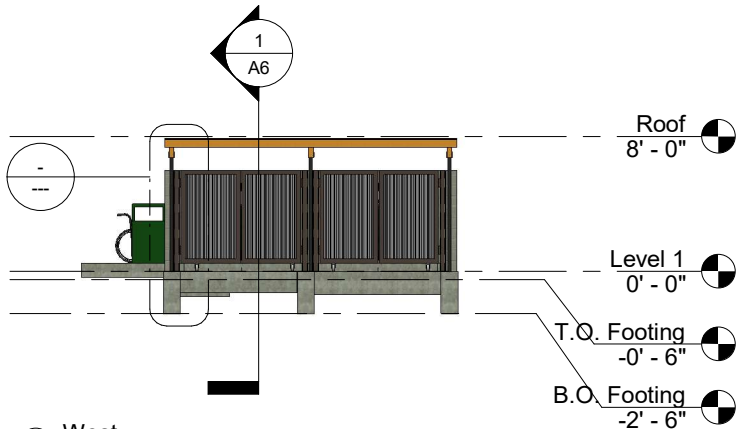

② West
1/8" = 1'-0"



www.sbcounty.gov

SB County 12'x17'-4" Enclosure

Elevations

Project number	Project Number
Date	Issue Date
Drawn by	Author
Checked by	Checker

A5

Scale 1/8" = 1'-0"

By using these standard plans, the user agrees to release the County of San Bernardino from any and all claims, liabilities, suits, and demands on account of any injury, damage, or loss to persons or property, including injury or death, or economic losses, arising out of the use of these construction documents. The use of these plans does not eliminate or reduce the user's responsibility to verify any and all information

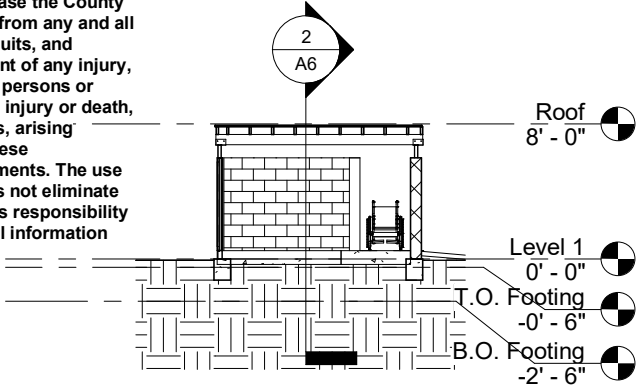

① Section 1
1/8" = 1'-0"

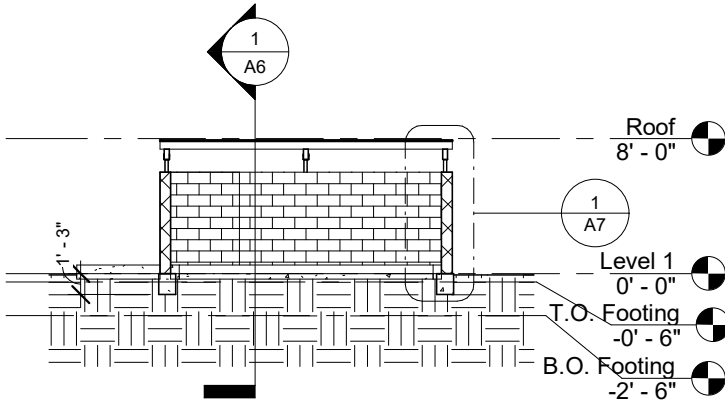

② Section 2
1/8" = 1'-0"



www.sbcounty.gov

SB County
12'x17'-4"
Enclosure

Building Sections

Project number	Project Number
Date	Issue Date
Drawn by	Author
Checked by	Checker

A6

Scale 1/8" = 1'-0"

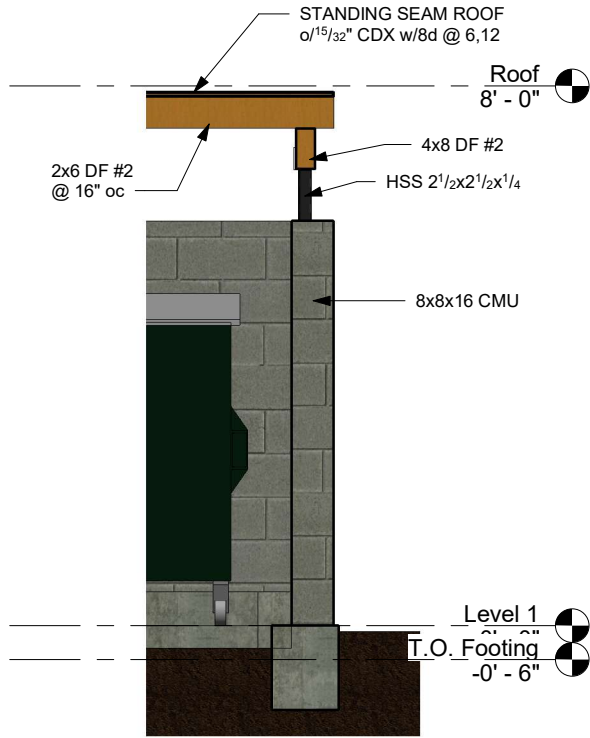

① Section 2 - Callout 1
 1/2" = 1'-0"



www.sbcounty.gov

SB County
 12'x17'-4"
 Enclosure

Wall Sections

Project number	Project Number
Date	Issue Date
Drawn by	Author
Checked by	Checker

A7

Scale 1/2" = 1'-0"

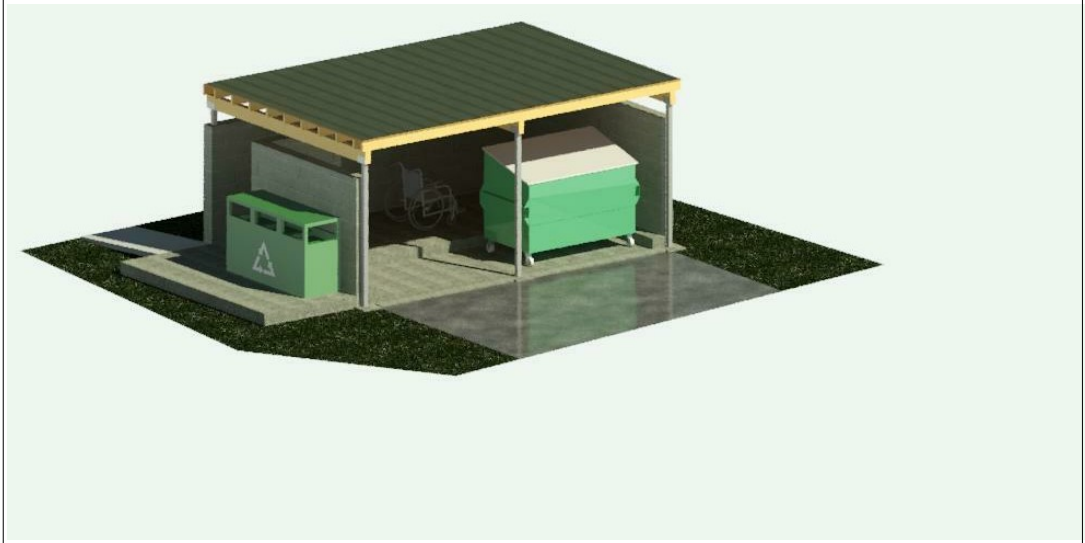

www.sbcounty.gov

**SB County
12'x17'-4"
Enclosure**

Building Perspectives

Project number	Project Number
Date	Issue Date
Drawn by	Author
Checked by	Checker

A9

Scale

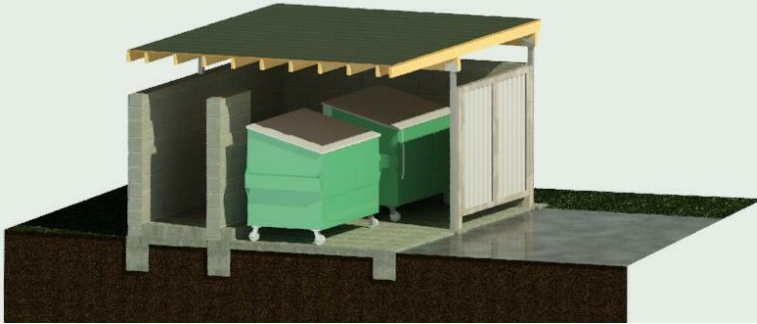

www.sbcounty.gov

**SB County
12'x17'-4"
Enclosure**

Building Perspectives

Project number	Project Number
Date	Issue Date
Drawn by	Author
Checked by	Checker

A10

Scale

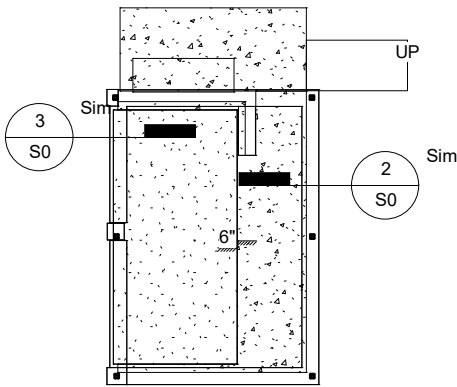

① Foundation
1/8" = 1'-0"

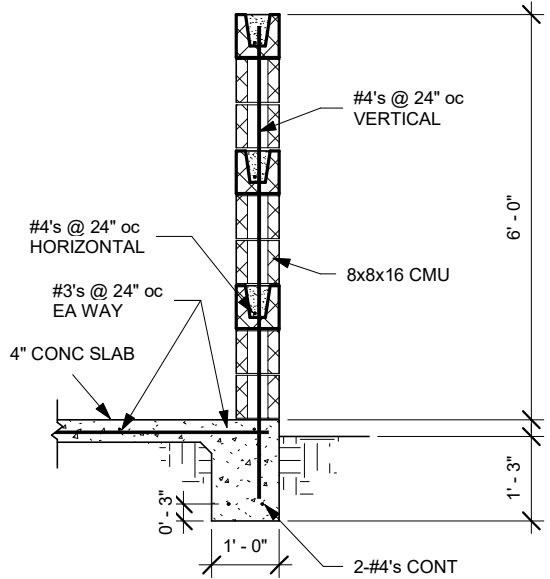

② Foundation/Wall Detail
1/2" = 1'-0"

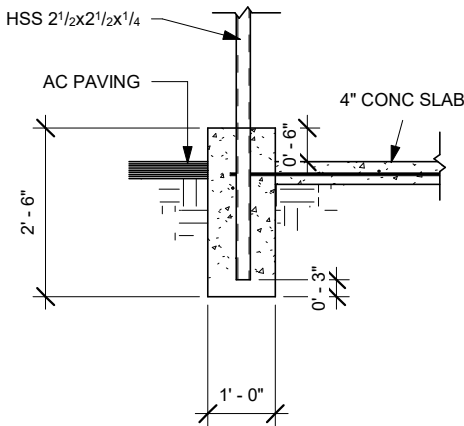

③ Cantilevered Column Foundation
1/2" = 1'-0"

By using these standard plans, the user agrees to release the County of San Bernardino from any and all claims, liabilities, suits, and demands on account of any injury, damage, or loss to persons or property, including injury or death, or economic losses, arising out of the use of these construction documents. The use of these plans does not eliminate or reduce the user's responsibility to verify any and all information



www.sbcounty.gov

SB County
12'x17'-4"
Enclosure

Foundation

Project number	Project Number
Date	Issue Date
Drawn by	Author
Checked by	Checker

S0

Scale As indicated

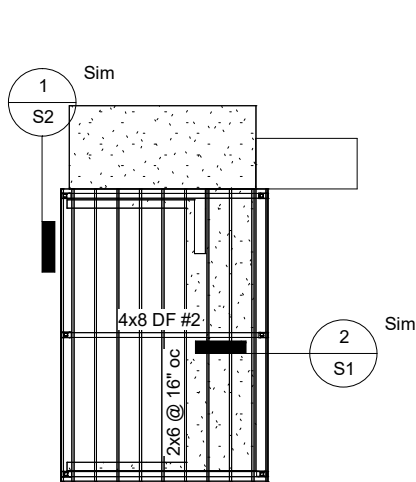

1 Roof Framing
1/8" = 1'-0"

By using these standard plans, the user agrees to release the County of San Bernardino from any and all claims, liabilities, suits, and demands on account of any injury, damage, or loss to persons or property, including injury or death, or economic losses, arising out of the use of these construction documents. The use of these plans does not eliminate or reduce the user's responsibility to verify any and all information

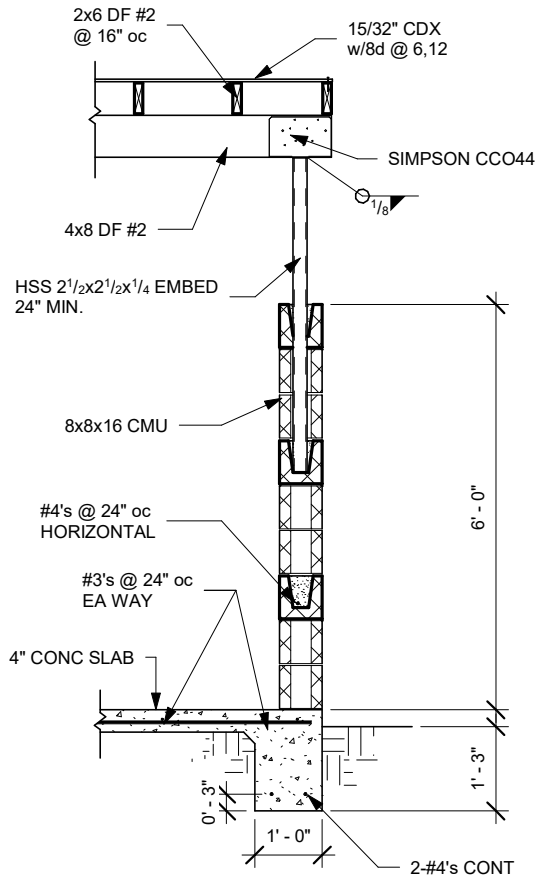

2 Wall/Framing Detail
1/2" = 1'-0"



www.sbcounty.gov

SB County
12'x17'-4"
Enclosure

Roof Framing

Project number	Project Number	S1
Date	Issue Date	
Drawn by	Author	
Checked by	Checker	Scale As indicated

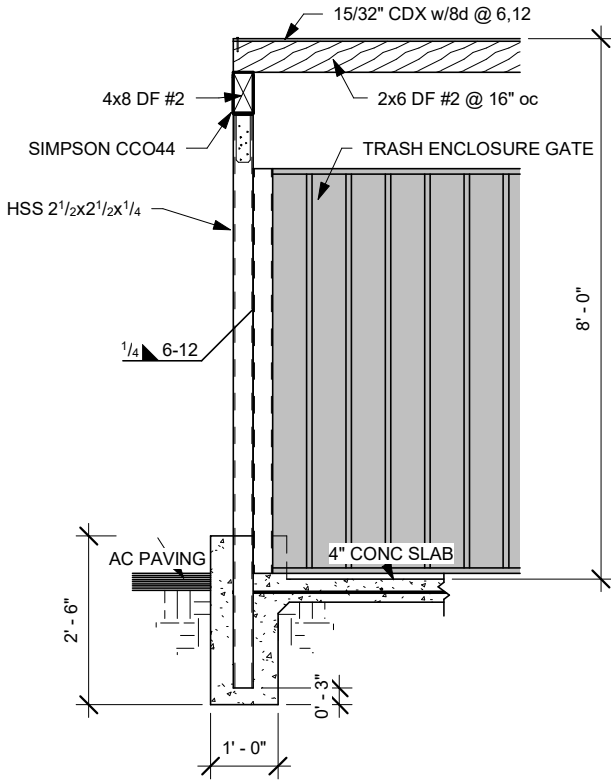

① Trash Enclosure Gate
1/2" = 1'-0"

By using these standard plans, the user agrees to release the County of San Bernardino from any and all claims, liabilities, suits, and demands on account of any injury, damage, or loss to persons or property, including injury or death, or economic losses, arising out of the use of these construction documents. The use of these plans does not eliminate or reduce the user's responsibility to verify any and all information



www.sbcounty.gov

SB County
12'x17'-4"
Enclosure

Details

Project number	Project Number	S2
Date	Issue Date	
Drawn by	Author	
Checked by	Checker	Scale 1/2" = 1'-0"